



Programme Area: Bioenergy

Project: TEA Biomass Pre-processing

Title: Analysis and Recommendations Report

Abstract:

This report (Deliverable 6) presents prioritised recommendations for further research into pre-processing technologies following the analysis of ten supply chains, two of which generate heat, and eight generating power to compare their costs, efficiencies and greenhouse gas emissions with and without pre-processing. These are compared in groups according to their shared conversion technology, and all the chains are able to use a blend of Miscanthus and woody feedstocks (from 0-100%). Every chain is described in the gPROMS model by a set of 200+ input parameters, each with a base case value and a minimum to maximum range.

Context:

The techno-economic project will provide a greater understanding of the options available to modify or improve the physical and chemical characteristics of different types of UK-derived 2nd generation energy biomass feedstocks, that may otherwise reduce the cost-effective performance of conversion technologies.

BI2011

Techno-Economic Assessment of Biomass Pre-Processing (TEABPP)

Deliverable 6: Analysis and Recommendations report

Version 3.0

The TEABPP Consortium

For the Energy Technologies Institute

November 2017

| | | |
|-----------------------|--|---|
| Title | Deliverable 6: Analysis and Recommendations report | |
| Client | Energy Technologies Institute | |
| Date | 22 November 2017 | |
| Authors | E4tech: | Richard Taylor, Hermen Westerbeeke, Lizzie German, Ausilio Bauen |
| | CMCL: | George Brownbridge, Amit Bhave, Nicola Bianco |
| | PSE: | Renato Wong, Adekola Lawal |
| | Imperial College Consultants: | Nilay Shah |
| | Black & Veatch: | Laura Martinez, Martin Eastwood |
| | University of Sheffield: | Kevin Hughes, Mohamed Pourkashanian |
| Reviewers/Approved by | E4tech: Jo Howes, Ausilio Bauen | |
| Version | 0.1 | Draft skeleton |
| | 0.2 | Final skeleton |
| | 0.3 | First draft with content |
| | 0.4 | First draft with all content from subcontractors |
| | 1.0 | Final version for review |
| | 1.1 | Revised draft version with updated analysis |
| | 2.0 | Revised final version |
| | 3.0 | Revised final version with minor edits |
| Distribution | ETI Programme Management team TEABPP Consortium | |

Contents

| | | |
|----------|--|------------|
| 1 | Executive Summary | 9 |
| 2 | Objectives | 15 |
| 3 | Introduction | 16 |
| 3.1 | Material included and excluded..... | 17 |
| 3.2 | Integration of gPROMS model with MoDS | 17 |
| 4 | Sensitivity analysis | 19 |
| 4.1 | Chain architectures | 19 |
| 4.2 | Selection of input parameter base cases and min-max ranges | 20 |
| 4.3 | Base case results | 20 |
| 4.4 | Summary of base case findings..... | 37 |
| 4.5 | Pie chart sensitivities..... | 42 |
| 4.6 | Spider chart sensitivities..... | 58 |
| 5 | Cross-over conditions | 84 |
| 5.1 | Cross-over charts..... | 84 |
| 5.2 | Venn diagrams | 104 |
| 5.3 | Summary of cross-over findings..... | 114 |
| 6 | Optimisation opportunities | 117 |
| 6.1 | Select parameters to optimise..... | 117 |
| 6.2 | Optimise by inspection..... | 117 |
| 6.3 | Optimum case results..... | 118 |
| 6.4 | Summary of optimum case findings..... | 128 |
| 6.5 | Impact of innovation | 129 |
| 6.6 | Summary of innovation findings..... | 146 |
| 7 | Setting innovation findings in a UK context | 149 |
| 7.1 | Technologies | 149 |
| 7.2 | Chains | 156 |
| 8 | Recommendations | 176 |
| 8.1 | Heat map summary of findings..... | 176 |
| 8.2 | Prioritised recommendations | 184 |

Table of figures

| | |
|--|----|
| Figure 4.1: Chain 1 architecture in gPROMS | 21 |
| Figure 4.2: Chain 1 base case LCOE component breakdown | 22 |
| Figure 4.3: Chain 2 architecture in gPROMS | 23 |
| Figure 4.4: Chain 2 base case LCOE component breakdown | 23 |
| Figure 4.5: Chain 3 architecture in gPROMS | 25 |
| Figure 4.6: Chain 3 base case LCOE component breakdown | 25 |
| Figure 4.7: Chain 4 architecture in gPROMS | 26 |
| Figure 4.8: Chain 4 base case LCOE component breakdown | 27 |
| Figure 4.9: Chain 5 architecture in gPROMS | 28 |
| Figure 4.10: Chain 5 base case LCOE component breakdown | 28 |
| Figure 4.11: Chain 6 architecture in gPROMS | 29 |
| Figure 4.12: Chain 6 base case LCOE component breakdown | 30 |
| Figure 4.13: Chain 7 architecture in gPROMS | 31 |
| Figure 4.14: Chain 7 base case LCOE component breakdown | 31 |
| Figure 4.15: Chain 8 architecture in gPROMS | 33 |
| Figure 4.16: Chain 8 base case LCOE component breakdown | 33 |
| Figure 4.17: Chain 9 architecture in gPROMS | 34 |
| Figure 4.18: Chain 9 base case LCOE component breakdown | 35 |
| Figure 4.19: Chain 10 architecture in gPROMS | 36 |
| Figure 4.20: Chain 10 base case LCOE component breakdown | 36 |
| Figure 4.21: Chain 1 LCOE sensitive parameters pie chart | 43 |
| Figure 4.22: Chain 1 net efficiency sensitive parameters pie chart | 43 |
| Figure 4.23: Chain 1 GHG emissions sensitive parameters pie chart | 43 |
| Figure 4.24: Chain 2 LCOE sensitive parameters pie chart | 45 |
| Figure 4.25: Chain 2 net efficiency sensitive parameters pie chart | 45 |
| Figure 4.26: Chain 2 GHG emissions sensitive parameters pie chart | 45 |
| Figure 4.27: Chain 3 LCOE sensitive parameters pie chart | 46 |
| Figure 4.28: Chain 3 net efficiency sensitive parameters pie chart | 46 |
| Figure 4.29: Chain 3 GHG emissions sensitive parameters pie chart | 46 |
| Figure 4.30: Chain 4 LCOE sensitive parameters pie chart | 48 |
| Figure 4.31: Chain 4 net efficiency sensitive parameters pie chart | 48 |
| Figure 4.32: Chain 4 GHG emissions sensitive parameters pie chart | 48 |
| Figure 4.33: Chain 5 LCOE sensitive parameters pie chart | 49 |
| Figure 4.34: Chain 5 net efficiency sensitive parameters pie chart | 49 |
| Figure 4.35: Chain 5 GHG emissions sensitive parameters pie chart | 49 |
| Figure 4.36: Chain 6 LCOE sensitive parameters pie chart | 51 |
| Figure 4.37: Chain 6 net efficiency sensitive parameters pie chart | 51 |
| Figure 4.38: Chain 6 GHG emissions sensitive parameters pie chart | 51 |
| Figure 4.39: Chain 7 LCOE sensitive parameters pie chart | 52 |
| Figure 4.40: Chain 7 net efficiency sensitive parameters pie chart | 52 |
| Figure 4.41: Chain 7 GHG emissions sensitive parameters pie chart | 52 |
| Figure 4.42: Chain 8 LCOE sensitive parameters pie chart | 54 |
| Figure 4.43: Chain 8 net efficiency sensitive parameters pie chart | 54 |

| | |
|--|----|
| Figure 4.44: Chain 8 GHG emissions sensitive parameters pie chart | 54 |
| Figure 4.45: Chain 9 LCOE sensitive parameters pie chart | 55 |
| Figure 4.46: Chain 9 net efficiency sensitive parameters pie chart | 55 |
| Figure 4.47: Chain 9 GHG emissions sensitive parameters pie chart | 55 |
| Figure 4.48: Chain 10 LCOE sensitive parameters pie chart | 57 |
| Figure 4.49: Chain 10 net efficiency sensitive parameters pie chart | 57 |
| Figure 4.50: Chain 10 GHG emissions sensitive parameters pie chart | 57 |
| Figure 4.51: Chain 1 LCOE sensitive parameters spider chart | 60 |
| Figure 4.52: Chain 1 net efficiency sensitive parameters spider chart | 61 |
| Figure 4.53: Chain 1 GHG emissions sensitive parameters spider chart | 62 |
| Figure 4.54: Chain 2 LCOE sensitive parameters spider chart | 63 |
| Figure 4.55: Chain 2 net efficiency sensitive parameters spider chart | 63 |
| Figure 4.56: Chain 2 GHG emissions sensitive parameters spider chart | 64 |
| Figure 4.57: Chain 3 LCOE sensitive parameters spider chart | 65 |
| Figure 4.58: Chain 3 net efficiency sensitive parameters spider chart | 66 |
| Figure 4.59: Chain 3 GHG emissions sensitive parameters spider chart | 67 |
| Figure 4.60: Chain 4 LCOE sensitive parameters spider chart | 68 |
| Figure 4.61: Chain 4 net efficiency sensitive parameters spider chart | 69 |
| Figure 4.62: Chain 4 GHG emissions sensitive parameters spider chart | 69 |
| Figure 4.63: Chain 5 LCOE sensitive parameters spider chart | 70 |
| Figure 4.64: Chain 5 net efficiency sensitive parameters spider chart | 71 |
| Figure 4.65: Chain 5 GHG emissions sensitive parameters spider chart | 72 |
| Figure 4.66: Chain 6 LCOE sensitive parameters spider chart | 73 |
| Figure 4.67: Chain 6 net efficiency sensitive parameters spider chart | 73 |
| Figure 4.68: Chain 6 GHG emissions sensitive parameters spider chart | 74 |
| Figure 4.69: Chain 7 LCOE sensitive parameters spider chart | 75 |
| Figure 4.70: Chain 7 net efficiency sensitive parameters spider chart | 75 |
| Figure 4.71: Chain 7 GHG emissions sensitive parameters spider chart | 76 |
| Figure 4.72: Chain 8 LCOE sensitive parameters spider chart | 77 |
| Figure 4.73: Chain 8 net efficiency sensitive parameters spider chart | 77 |
| Figure 4.74: Chain 8 GHG emissions sensitive parameters spider chart | 78 |
| Figure 4.75: Chain 9 LCOE sensitive parameters spider chart | 79 |
| Figure 4.76: Chain 9 net efficiency sensitive parameters spider chart | 79 |
| Figure 4.77: Chain 9 GHG emissions sensitive parameters spider chart | 80 |
| Figure 4.78: Chain 10 LCOE sensitive parameters spider chart | 81 |
| Figure 4.79: Chain 10 net efficiency sensitive parameters spider chart | 82 |
| Figure 4.80: Chain 10 GHG emissions sensitive parameters spider chart | 83 |
| Figure 5.1: Chain 2-1 delta LCOE vs. Blending split cross-over chart | 86 |
| Figure 5.2: Chain 4-3 delta LCOE vs. Miscanthus screening unit inlet mass rate cross-over chart | 88 |
| Figure 5.3: Chain 4-3 delta LCOE vs. woody log storage time cross-over chart | 89 |
| Figure 5.4: Chain 6-5 (blue) and Chain 7-5 (red) delta LCOE vs. screened chips/pellet transport distance cross-over chart | 90 |
| Figure 5.5: Chain 6-5 (blue) and Chain 7-5 (red) delta GHG emissions vs. screened chips/pellet transport distance cross-over chart | 91 |

| | |
|--|-----|
| Figure 5.6: Chain 6-5 (blue) and Chain 7-5 (red) delta LCOE vs. warehouse storage time cross-over chart | 92 |
| Figure 5.7: Chain 6-5 (blue) and Chain 7-5 (red) delta LCOE vs. silo storage time cross-over chart.... | 93 |
| Figure 5.8: Chain 6-5 (blue) and Chain 7-5 (red) delta LCOE vs. blending split cross-over chart..... | 94 |
| Figure 5.9: Chain 9-8 (blue) and Chain 10-8 (red) delta LCOE vs. silo/tank storage time cross-over chart | 95 |
| Figure 5.10: Chain 9-8 (blue) and Chain 10-8 (red) delta LCOE vs. torrefied pelleting LHV multiplier cross-over chart..... | 96 |
| Figure 5.11: Chain 9-8 (blue) and Chain 10-8 (red) delta GHG emissions vs. torrefied pelleting LHV multiplier cross-over chart..... | 97 |
| Figure 5.12: Chain 9-8 (blue) and Chain 10-8 (red) delta GHG emissions vs. torrefied pelleting input electricity multiplier cross-over chart | 98 |
| Figure 5.13: Chain 9-8 (blue) and Chain 10-8 (red) delta LCOE vs. torrefied pelleting total installed CAPEX multiplier cross-over chart..... | 99 |
| Figure 5.14: Chain 9-8 (blue) and Chain 10-8 (red) delta LCOE vs. pyrolysis CAPEX scaling factor cross-over chart..... | 100 |
| Figure 5.15: Chain 9-8 (blue) and Chain 10-8 (red) delta GHG emissions vs. pyrolysis electricity output multiplier cross-over chart..... | 101 |
| Figure 5.16: Chain 9-8 (blue) and Chain 10-8 (red) delta LCOE vs. Miscanthus inherent ash content cross-over chart..... | 102 |
| Figure 5.17: Chain 9-8 (blue) and Chain 10-8 (red) delta GHG emissions vs. Miscanthus inherent ash content cross-over chart..... | 103 |
| Figure 5.18: Chain 1 vs. 2 LCOE Venn diagram..... | 105 |
| Figure 5.19: Chain 3 vs. 4 LCOE Venn diagram..... | 106 |
| Figure 5.20: Chain 5 vs. 6 LCOE Venn diagram..... | 107 |
| Figure 5.21: Chain 5 vs. 6 net efficiency Venn diagram..... | 108 |
| Figure 5.22: Chain 5 vs. 6 GHG emissions Venn diagram | 108 |
| Figure 5.23: Chain 5 vs. 7 LCOE Venn diagram..... | 108 |
| Figure 5.24: Chain 5 vs. 7 net efficiency Venn diagram..... | 109 |
| Figure 5.25: Chain 8 vs. 9 LCOE Venn diagram..... | 110 |
| Figure 5.26: Chain 8 vs. 9 net efficiency Venn diagram..... | 111 |
| Figure 5.27: Chain 8 vs. 9 GHG emissions Venn diagram | 111 |
| Figure 5.28: Chain 8 vs. 10 LCOE Venn diagram..... | 112 |
| Figure 5.29: Chain 8 vs. 10 net efficiency Venn diagram..... | 113 |
| Figure 5.30: Chain 8 vs. 10 GHG emissions Venn diagram | 114 |
| Figure 6.1: Chain 1 optimum case LCOE component breakdown | 118 |
| Figure 6.2: Chain 2 optimum case LCOE component breakdown | 119 |
| Figure 6.3: Chain 3 optimum case LCOE component breakdown | 120 |
| Figure 6.4: Chain 4 optimum case LCOE component breakdown | 121 |
| Figure 6.5: Chain 5 optimum case LCOE component breakdown | 122 |
| Figure 6.6: Chain 6 optimum case LCOE component breakdown | 123 |
| Figure 6.7: Chain 7 optimum case LCOE component breakdown | 124 |
| Figure 6.8: Chain 8 optimum case LCOE component breakdown | 125 |
| Figure 6.9: Chain 9 optimum case LCOE component breakdown | 126 |
| Figure 6.10: Chain 10 optimum case LCOE component breakdown | 127 |

Table of tables

| | |
|---|-----|
| Table 1.1: Comparison of base case results for the 10 chains (th = heat, e = power) | 10 |
| Table 1.2: Comparison of the ability of chains to achieve cross-overs | 12 |
| Table 1.3: Comparison of optimum case results for the 10 chains | 13 |
| Table 4.1: Chain 1 base case LCOE component breakdown | 22 |
| Table 4.2: Chain 2 base case LCOE component breakdown | 24 |
| Table 4.3: Chain 3 base case LCOE component breakdown | 25 |
| Table 4.4: Chain 4 base case LCOE component breakdown | 27 |
| Table 4.5: Chain 5 base case LCOE component breakdown | 29 |
| Table 4.6: Chain 6 base case LCOE component breakdown | 30 |
| Table 4.7: Chain 7 base case LCOE component breakdown | 32 |
| Table 4.8: Chain 8 base case LCOE component breakdown | 33 |
| Table 4.9: Chain 9 base case LCOE component breakdown | 35 |
| Table 4.10: Chain 10 base case LCOE component breakdown | 37 |
| Table 4.11: Comparison of base case results for the 10 chains | 38 |
| Table 4.12: Warning flags raised in gPROMS at the base case for the 10 chains | 41 |
| Table 5.1: Comparison of base case chain preferences under uncertainty | 115 |
| Table 5.2: Comparison of the ability of chains to achieve cross-overs | 116 |
| Table 6.1: Chain 1 optimum case LCOE component breakdown | 118 |
| Table 6.2: Chain 2 optimum case LCOE component breakdown | 119 |
| Table 6.3: Chain 3 optimum case LCOE component breakdown | 120 |
| Table 6.4: Chain 4 optimum case LCOE component breakdown | 121 |
| Table 6.5: Chain 5 optimum case LCOE component breakdown | 122 |
| Table 6.6: Chain 6 optimum case LCOE component breakdown | 123 |
| Table 6.7: Chain 7 optimum case LCOE component breakdown | 124 |
| Table 6.8: Chain 8 optimum case LCOE component breakdown | 125 |
| Table 6.9: Chain 9 optimum case LCOE component breakdown | 126 |
| Table 6.10: Chain 10 optimum case LCOE component breakdown | 127 |
| Table 6.11: Comparison of optimum case results for the 10 chains | 128 |
| Table 6.12: Key technical innovation parameters within Chain 1 | 130 |
| Table 6.13: Key technical innovation parameters within Chain 2 | 132 |
| Table 6.14: Key technical innovation parameters within Chain 3 | 133 |
| Table 6.15: Key technical innovation parameters within Chain 4 | 135 |
| Table 6.16: Key technical innovation parameters within Chain 5 | 136 |
| Table 6.17: Key technical innovation parameters within Chain 6 | 138 |
| Table 6.18: Key technical innovation parameters within Chain 7 | 139 |
| Table 6.19: Key technical innovation parameters within Chain 8 | 140 |
| Table 6.20: Key technical innovation parameters within Chain 9 | 142 |
| Table 6.21: Key technical innovation parameters within Chain 10 | 144 |
| Table 6.22: Top 3 technical innovation parameter impacts for each chain | 147 |
| Table 8.1: Chain 2 vs. 1 quantitative and qualitative summary | 177 |
| Table 8.2: Chain 4 vs. 3 quantitative and qualitative summary | 179 |
| Table 8.3: Chains 7 & 6 vs. 5 quantitative and qualitative summary | 181 |
| Table 8.4: Chains 10 & 9 vs. 8 quantitative and qualitative summary | 182 |

Glossary

| | | | |
|------------------------|--|-----------------------|--|
| ARBRE | Arable Biomass Renewable Energy | Kg | Kilogram |
| BFB | Bubbling Fluidised Bed | LCOE | Levelised Cost Of Energy |
| BECCS | Bioenergy with Carbon Capture and Storage | LHV | Lower Heating Value |
| CAPEX | CApital EXPenditure | LRF | Long Rotation Forestry |
| CCGT | Combined Cycle Gas Turbine | MJ | Megajoule |
| CEG | Clean Electricity Generation B.V. | MoDS | CMCL's Model Development Suite |
| CFB | Circulating Fluidised Bed | MSW | Municipal Solid Waste |
| CHP | Combined Heat and Power | MWh | MegaWatt hour |
| Cl | Chlorine | N | Nitrogen |
| CMCL | Computational Modelling Cambridge Ltd. | NO_x | Nitrogen Oxides |
| CO | Carbon Monoxide | odt | Oven Dried Tonne |
| CO₂ | Carbon Dioxide | OPEX | Annual Operating Costs |
| CO_{2e} | Carbon Dioxide Equivalent | PM | Particulate Matter |
| ECN | Energieonderzoek Centrum Nederland (Energy Research Centre of The Netherlands) | PSD | Particle Size Distribution |
| EF | Entrained Flow | PSE | Process Systems Enterprise Ltd. |
| EN-A2 | ENplus A2 (pellet standard) | R&D | Research and Development |
| EPC | Engineering, Procurement, Construction | RDF | Refuse Derived Fuel |
| EU | European Union | RED | Renewable Energy Directive |
| GHG | Greenhouse Gas | RHI | Renewable Heat Incentive |
| GJ | Gigajoule | RO | Renewables Obligation |
| gPROMS | PSE's process model platform | S | Sulphur |
| GUI | Graphical User Interface | SNCR | Selective Non-Catalytic Reduction |
| H₂ | Hydrogen | SRC | Short Rotation Coppice |
| IGCC | Integrated Gasification Combined Cycle | SRF | Short Rotation Forestry |
| | | STU | "STU Boiler" manufactured By Hoval |
| | | TRL | Technology Readiness Level |

1 Executive Summary

The Techno-Economic Assessment of Biomass Pre-Processing (TEABPP) project compares the costs, efficiencies and GHG emissions of biomass supply chains “with” and “without” significant pre-processing, to assess whether and how pre-processing steps can benefit UK bioenergy supply chains.

Ten supply chains were selected for modelling and analysis in the project, two of which generate heat, and eight generating power. These are compared in groups according to their shared conversion technology, and all the chains are able to use a blend of Miscanthus and woody feedstocks (from 0-100%). Every chain is described in the gPROMS model by a set of 200+ input parameters, each with a base case value and a minimum to maximum range.

High-level description of the 10 chains analysed in TEABPP

| Chain | Pre-processing | Storage step(s) | Blending point | Conversion technology | End vector |
|-------|------------------------|----------------------------|-------------------|--|------------|
| 1 | Screening | Shed | At conversion | Underfeed stoker combustion boiler | Heat |
| 2 | Screening + field wash | Shed | At conversion | | Heat |
| 3 | Screening | Shed/tarp | At conversion | Bubbling fluidised bed (BFB) gasifier + syngas engine | Power |
| 4 | Water wash + pellet | Shed/tarp, warehouse | At pre-processing | | Power |
| 5 | Screening | Shed/tarp, warehouse | At pre-processing | Circulating fluidised bed (CFB) combustion + steam turbine | Power |
| 6 | Pelleting | Shed/tarp, silo | At pre-processing | | Power |
| 7 | Chemical wash + pellet | Shed/tarp, warehouse, silo | At pre-processing | | Power |
| 8 | Pelleting | Shed/tarp, silo | At pre-processing | Entrained flow (EF) gasifier + syngas CCGT | Power |
| 9 | Torrefy + pellet | Shed/tarp, silo | At pre-processing | | Power |
| 10 | Pyrolysis | Shed/tarp, tank | At pre-processing | | Power |

Using the base case values for each input parameter, the chain results shown in Table 1.1 are derived¹. At the base case, all the chains are relatively high cost compared to other renewable heating or power generation options in the UK (i.e. those outside of the TEABPP scope). In general, **the chains with the least amount of pre-processing are the cheapest, most efficient and have the lowest GHG emissions within each grouping of similar chains.**

Chains 1 & 2 are efficient (as producing only heat) and have low GHG emissions due to the local supply of biomass, and adding field washing is relatively inexpensive. In contrast, water washing or chemical washing (then pelleting) adds significant costs and GHG emissions in Chains 4 and 7. Whilst most of the chains are well under UK regulatory GHG thresholds, Chain 7 might be at risk of exceeding post-2025 limits. Pyrolysis in Chain 10 is relatively inefficient and high cost, but has the advantage of low GHG emissions. The impacts of adding torrefaction in Chain 9 are relatively modest

¹ The chain net total levelised cost of energy (LCOE) is the key cost metric used in TEABPP. Gross chain efficiency = energy output divided by feedstocks collected, net chain efficiency = gross efficiency less other energy inputs to the chain (such as diesel used in trucking). The GHG emissions have been calculated on a basis compliant with UK regulations.

compared to Chain 8 pelleting, but using pelleting (in Chain 6) is still a step up in cost and GHG emissions compared to only using screened chips (in Chain 5).

Table 1.1: Comparison of base case results for the 10 chains (th = heat, e = power)

| Chain | LCOE (£/MWh) | Net efficiency (%) | Gross efficiency (%) | GHG emissions (kgCO ₂ e/MWh) |
|------------------------------------|--------------|--------------------|----------------------|---|
| 1 - screen, boiler | 53 [th] | 78.9 | 83.1 | 33 [th] |
| 2 - screen, field wash, boiler | 57 [th] | 76.1 | 80.8 | 37 [th] |
| 3 - screen, BFB gasify | 172 [e] | 24.0 | 27.9 | 87 [e] |
| 4 - water wash, pellet, BFB gasify | 197 [e] | 18.1 | 25.9 | 175 [e] |
| 5 - screen, CFB combust | 123 [e] | 26.3 | 31.6 | 89 [e] |
| 6 - pellet, CFB combust | 144 [e] | 23.4 | 31.6 | 147 [e] |
| 7 - chem wash, pellet, CFB combust | 164 [e] | 22.0 | 30.5 | 199 [e] |
| 8 - pellet, EF gasify | 124 [e] | 29.8 | 38.0 | 122 [e] |
| 9 - torrefy+pellet, EF gasify | 132 [e] | 26.3 | 34.1 | 135 [e] |
| 10 - pyrolysis, EF gasify | 182 [e] | 17.9 | 21.7 | 100 [e] |

TEABPP also highlights the key modelling sensitivities using a series of cost component charts, sensitivity pie charts and spider charts for each chain in turn, allowing identification of which input parameters most strongly influence chain costs, efficiency and GHG emissions. This sensitivity analysis detailed in Section 4 shows that the **final conversion technology CAPEX and efficiency** typically have the greatest influence on chain costs. This leads to the conclusion that the CAPEX for the final conversion technologies, and the delivered feedstock cost, have to be low for successful application of these bioenergy chains in the UK. The **final conversion technology efficiency and feedstock transport distances** typically have the greatest impact on chain net efficiencies and GHG emissions, which suggests that to remain compliant with UK GHG regulations, final conversion efficiencies have to stay high and road transport distances stay relatively low. This recommendation is in conflict with some of the cross-over analysis, which shows very high transport distances are often required to see net LCOE benefits of pre-processing over chains with minimal pre-processing – but both these chains may then have GHG emissions that exceed UK GHG limits.

Biomass characteristics, blending and pre-processing parameters only appear in some of the sensitivity charts, and typically do not dominate the top 5 most sensitive parameters in each chain. Those that do appear as key sensitivities vary by chain, but include:

- The impact of feedstock **ash content on pyrolysis** efficiencies – i.e. minimising feedstock ash content will improve pyrolysis chains.
- The **LHV of torrefied pellets** – i.e. higher energy densities will improve torrefaction chains due to less diesel used in trucking, and smaller silo stores.
- High **feedstock nitrogen** contents require NO_x mitigation in power generation, which usually entails urea use and its associated GHG emissions – particularly important if chemical washing is adding nitrogen to the feedstock. Low nitrogen biomass could therefore avoid urea use, but of all the pre-processing technologies characterised, only pyrolysis is expected to be able to lower nitrogen contents.

- The **blending split** between Miscanthus and woody feedstocks generally favours the use of cleaner woody feedstocks (despite their higher starting moisture content) over Miscanthus.

Insights gained from the sensitivity analysis suggests that there is a rough order of priority in terms of the biomass parameters that have the greatest influence on chain costs – noting that this list is generic, and there will be some differences between chains. Typically, the starting **feedstock cost** is the most important biomass parameter, followed by the feedstock **energy density** (i.e. combination of LHV and volumetric density, for transport costs), and then its **moisture content** (for conversion plant efficiencies). This is then usually followed by the total **ash content** (due to modest impacts on opex, efficiency and downtime), and then the **Nitrogen content** (if able to avoid SNCR kit and urea), followed by **Chlorine and Alkali index** (which can multiply into an effective Chlorine content for enhanced corrosion). **Soil and stone contamination** is only a part of the total ash, and then the remaining biomass parameters either have small impacts (e.g. Sulphur), or are assumed to have no impact at all (e.g. Calcium, Aluminium).

Warning flags are raised in gPROMS if any biomass parameters cross their specified limits. gPROMS results are still calculated, but need to be treated with caution, as there could be implications for equipment lifetime, emissions permits, over-extrapolation of trends, or that a different supplier's technology (with different costs/performance) is required in order to use the feedstock. At the base case blend of 50% Miscanthus, 50% woody, warning flags are raised for all the chains without pre-processing. **Only water washing, chemical washing and pyrolysis can clean the blended biomass far enough to avoid any warning flags** – screening, field washing, pelleting and torrefaction+pelleting are too mild (or concentrate contaminants). This suggests that although water washing, chemical washing and pyrolysis are unable to lower overall chain costs and have few cross-overs, these pre-processing technologies might be required by some plant operators to be able to use this 50% Miscanthus blend, and still meet their performance guarantees, expected lifetimes and/or gaseous emissions permits. The effectiveness of each pre-processing technology in removing (or adding to) each biomass contaminant is summarised in the D3 report.

A “cross-over” occurs when by varying one input parameter, a chain with processing (one of Chains 2, 4, 6-7 or 9-10) goes from being worse to being better than the comparator chain without significant pre-processing (Chains 1, 3, 5 or 8 respectively). This is a clear cross-over if 95% of the gPROMS scatter points show a clear separation, or an unclear cross-over if there are overlapping uncertainty ranges. Section 5 uses cross-over charts and Venn diagrams to show the parameter regions where the benefits or costs of adding pre-processing are clear or unclear. Table 1.2 summarises the cross-over results for each chain pair.

Table 1.2: Comparison of the ability of chains to achieve cross-overs

| Chain pair | LCOE delta | Net efficiency delta | GHG emissions delta |
|------------|---|--|---|
| 2 vs. 1 | No options | No options | No options |
| 4 vs. 3 | Few options, but none for a clear cross-over | No options | No options |
| 6 vs. 5 | Some options, and for a clear cross-over | Some options, and for a clear cross-over | No options |
| 7 vs. 5 | No options | No options | No options |
| 9 vs. 8 | Some options, but none for a clear cross-over | No options | Few options, but none for a clear cross-over |
| 10 vs. 8 | No options | No options | Many options, but none for a clear cross-over |

Most Venn diagrams show a clear or unclear preference for the chains “without” pre-processing, except in a few cases² where **wet or low density biomass is being trucked very long distances or stored for a long time, when some cross-overs do appear** (but are still mostly unclear due to uncertainties). Trucking pellets instead of chips more than 800km gives the only clear cross-over in the TEABPP analysis, i.e. **pelleting chains can out-perform screened chip chains** – but the transport distances required are unlikely to ever be seen in the UK, and could have GHG emissions compliance issues. There are also **some options for torrefaction + pelleting to potentially match pelleting** on cost or GHG emissions at the base case distances (150km), or potentially out-perform pelleting if the transport distances were greater. In contrast, **pyrolysis only has the potential benefits of low GHG emissions**, and no chance of achieving cost or efficiency cross-overs.

Other pre-processing options such as field wash and chemical washing do not have a significant chance of achieving chain benefits, and the benefits of water washing + pelleting over screening are dominated by the pelleting benefits, not the water washing. In general, all the washing chains (2, 4, 7) show slightly enhanced pre-processing benefits when washing Miscanthus compared to when using cleaner woody feedstocks – i.e. **washing is more beneficial to dirtier feedstocks**. Even still, the added costs and often significant added moisture content from washing remain as downsides, and there are safety risks with storage of wet chips for extended periods of time. Co-location of washing and pelleting is expected to help overcome some of these barriers, and also help make some modest savings on pre-processing opex (in Chains 4 and 7), but the limit of 10 chains within TEABPP meant we could not also include chains with geographically separated washing and pelleting steps in order to do a full comparison of without and without co-location.

For a selected number of technical innovations in the conversion and pre-processing steps identified by the TEABPP team, Section 6 assesses which of these innovations result in the largest chain improvements, to highlight where the biggest gains can be pursued through innovation (with specific innovation targets for each technology discussed in Section 6.5). Optimising all of these selected parameters together leads to a significantly improved set of chain costs, efficiencies and GHG emissions from the original base case values, as shown below in Table 1.3.

² Or when very small-scale/expensive pre-processing (i.e. screening or pelleting) is being used in the comparator chain – although this is not necessarily a fair comparison, given the scales of the steps in the different chains are independent parameters.

Table 1.3: Comparison of optimum case results for the 10 chains

| Chain | LCOE (£/MWh) | Net efficiency (%) | Gross efficiency (%) | GHG emissions (kgCO ₂ e/MWh) |
|--|--------------------|--------------------|----------------------|---|
| 1 - screen, boiler (<i>heat</i>) | 35 ^[th] | 95.1 | 97.3 | 19 ^[th] |
| 2 - screen, field wash, boiler (<i>heat</i>) | 36 ^[th] | 92.2 | 94.9 | 22 ^[th] |
| 3 - screen, BFB gasify | 75 ^[e] | 40.4 | 42.4 | 41 ^[e] |
| 4 - water wash, pellet, BFB gasify | 97 ^[e] | 33.4 | 39.2 | 92 ^[e] |
| 5 - screen, CFB combust | 81 ^[e] | 32.7 | 37.4 | 69 ^[e] |
| 6 - pellet, CFB combust | 98 ^[e] | 30.1 | 37.4 | 110 ^[e] |
| 7 - chem wash, pellet, CFB combust | 104 ^[e] | 28.4 | 35.8 | 128 ^[e] |
| 8 - pellet, EF gasify | 71 ^[e] | 50.3 | 57.1 | 68 ^[e] |
| 9 - torr+pellet, EF gasify | 70 ^[e] | 48.4 | 54.5 | 68 ^[e] |
| 10 - pyrolysis, EF gasify | 74 ^[e] | 44.5 | 48.0 | 24 ^[e] |

The optimum case chain costs are much more competitive in the UK renewables context, and all the chains are **comfortably below even the post-2025 GHG thresholds**, in part due to significantly higher chain efficiencies than in the base case. There are also a few changes in the ranking of chains (e.g. Chain 9 could just become cheaper than Chain 8, and with the same GHG emissions), and in general **the gap between chains with and without pre-processing has reduced significantly**. However, none of the pre-processing opportunities lead to clearly better chain costs – **significant uncertainties remain with any cross-overs**. This leads us to the conclusion that if pre-processing is to work in the UK, then significant work needs to happen to simultaneously improve a large number of pre-processing parameters (CAPEX, efficiencies, material/energy use, product quality), and reduce inherent uncertainties.

Final **conversion technology CAPEX and efficiencies** still dominate the breakdown of optimum case costs, and these conversion parameters also dominate the innovation opportunities for Chains 1-5. However, in Chains 6-10, there are some pre-processing opportunities that offer greater potential to help close the cost gaps between chains:

- Increased **torrefied pellet LHV** drives Chain 9 cost and efficiency savings, with lower electricity use also contributing to improved GHG emissions.
- **Pyrolysis efficiency** is vital for making large improvements in all Chain 10 metrics, with pyrolysis electricity exports also giving a GHG credit.
- Lowering the **chemical washing output nitrogen content**, and lowering **alkali use**, leads to lower costs and GHG emissions in Chain 7.
- Reduction in **pelleting electricity and binder** use can provide modest GHG reductions in Chain 6.

Qualitative criteria such as each technology's commercial status and key development issues, UK actors, supply chain risks and barriers, and potential deployment opportunities within the UK are discussed in Section 7. Heat map summaries of the chain findings from the whole report are given in Section 8, and the following prioritised set of recommendations for further consideration for technology acceleration activities were then made:

- **Conversion technology** innovation improvements, especially CAPEX and efficiencies, result in dramatic chain improvements, and are worth exploring further as these will be required to increase the competitiveness of all of the TEABPP chains. Improvements in underfeed boilers and CFB combustion technologies can be achieved by existing actors in the near term, but developments in fluidised gasifiers and syngas engines for the near to mid-term, and EF gasifiers and syngas CCGT for the long-term will need more support given high risks and few developers. However, these conversion improvements do not fundamentally change the regions in which pre-processing pays off, and are not the primary focus of the TEABPP project. Some pre-processing improvements can further reduce conversion costs (e.g. avoiding SNCR kit); whereas others will reduce the scope or need for conversion technology improvements (e.g. plants are already operating more efficiently by using cleaner, drier feedstocks). **High priority.**
- **Torrefaction+pelleting** plants should focus on increasing product LHV, optimising with energy crop/SRF feedstocks, and reducing electricity use. Given the potential (but slim and uncertain) cost and GHG emission benefits over pelletizing if improvements are made, ETI, Supergen Bioenergy or the Research councils should investigate torrefaction developments and look to reduce uncertainties in the near-term. **Medium-high priority.**
- **Chemical washing** plants, if developed, should focus on reducing output nitrogen content and lowering chemical use and GHG emissions, plus safely dealing with waste water disposal. ETI, Supergen Bioenergy or the Research councils could have a role in supporting this R&D in the mid-term, but scaling up will take time, and is dependent on further costs reductions and water washing success. **Medium priority.**
- **Water washing** plants should focus on optimisation with forestry then perennial energy crop feedstocks, and compliance with combustion and gasification plant feedstock limits and non-GHG emissions limits. Recommendation for ETI, Supergen Bioenergy or industry to carry out washed biomass testing in gasification plants in the near to mid-term. **Medium priority.**
- **Pyrolysis** plants should focus on significantly improving bio-oil yields when using higher-ash energy crop/SRF feedstocks, and overall plant thermal integration. ETI, Supergen Bioenergy or the Research councils could have a role in supporting this R&D in the mid-term, and reducing technology uncertainties, but power generation via pyrolysis is still likely to remain expensive and only as a long term potential option. **Medium priority.**
- **Field washing** plants should focus on ash and halide removal, and optimisation with biomass. However, the technology does not appear to offer significant benefits to warrant further work, and given its simplicity, could be delivered by the market in the near to mid-term if required. **Low priority.**
- **Pelleting** plants should focus on reductions in power consumption and binder use, potentially replacing starch with cheaper waste materials, to drive down GHG emissions. These changes will likely be driven by existing markets and actors in the near term if required, and do not need intervention. Pelletizing was responsible for the only clear cross-over in TEABPP, based on >800km distances. **Low priority.**

2 Objectives

The objectives of this final report in the ETI's TEABPP project are to highlight the key biomass supply chain sensitivities using the model (i.e. which parameters strongly influence the output metrics); to analyse the circumstances where the benefits or costs of adding pre-processing are clear or unclear (due to parameter uncertainties); and to assess which technical innovations give the largest benefits and which pathway choices are most optimal. The report will therefore provide a justified short-list of technologies recommended for further consideration for technology acceleration activities, thereby informing the ETI's thinking, as well as a wider stakeholder community via the ETI.

This final report will enable the ETI to understand those input parameters that drive chain outcomes (where their focus should be); the parameter regions in which the benefits of selecting one chain over another are clear (where it is safe to draw conclusions); and the impact of technical innovation on overall chain performance (what the future potential benefits are). It will also help the ETI appreciate why optimal routes exist and understand the level of certainty associated with these conclusions.

The report includes for each chain:

- Identification and discussion of the Base Case conditions;
- Identification and justification of the most sensitive global factor;
- Discussion of the impact of changing parameters (including feedstock characteristics, feedstock blending, transport distances, scales and conversion improvements) on chain output metrics (cost, efficiency and GHG emissions);
- Identification and discussion of the Optimal Case conditions (varying only selected technical parameters);
- Innovation impact: Determining (with justifications from the consortium and project literature review) which of the pre-processing and conversion improvements present the largest potential reductions in overall chain cost and improvement in performance and emissions, and so quantify (realistic) future targets for key parameters. The discussion will give brief examples of how these improvements could be achieved (e.g. what technical changes are assumed).

The report also includes comparisons of chains:

- Examination and explanation of situations where there are clear (or unclear) benefits of adding pre-processing, and the key trade-offs made;
- Summary of Cross-Over points using Venn diagrams for a collection of key parameters;
- Recommendations: Identification of which pre-processing technologies could most improve UK biomass supply chains and hence potentially lead to increased and more effective bioenergy deployment, and hence which routes should be the focus of (short and/or longer term) supported acceleration activities.

3 Introduction

The report is structured as follows:

Section 4 highlights which parameters drive the modelling, by identifying the key modelling sensitivities:

- Section 4.1 and 4.2: discussion of the simplifications made to the chain architectures, and ranges allowed for each input parameter;
- Section 4.3 and 4.4: identification and justification of the **base case conditions** for each chain, giving the chain architecture used, a **chart with the breakdown of LCOE** into chain components, and a comparison of net chain LCOE, efficiencies and GHG emissions across all chains at their base case conditions;
- Section 4.5: identification and justification of the most sensitive global factors within each chain, using a series of **sensitivity pie charts** for the key output metrics (cost, performance and emissions);
- Section 4.6: identification and discussion of the impact of changing key parameters (including feedstock characteristics, feedstock blending, transport distances, scales and conversion improvements) on the key output metrics (cost, performance and emissions) for each chain, using a series of **spider charts**.

Section 5 compares the results of those chains that share the same conversion technology, in order to analyse the circumstances where the benefits or costs of adding pre-processing are clear or unclear (due to parameter uncertainties):

- Section 5.1: examination and explanation of situations where there are clear (or unclear) benefits of adding pre-processing, and the key trade-offs made. This will use **cross-over charts** provided from MoDS, including scatter points to show the uncertainty in the results;
- Section 5.2: summary of Cross-Over points using **Venn diagrams**, to show the conditions under which a collection of key parameters favour chains with pre-processing chains, without pre-processing, or when the situation is unclear.

Section 6 returns to the individual chains, assessing which technical innovations give the largest benefits and which pathway choices are therefore most optimal:

- Section 6.1 and 6.2: selection of the parameters to be optimised, and examination of the optimum value within the min-max range for each parameter selected;
- Section 6.3: identification and discussion of the **optimal case conditions** for each chain (only varying selected technical parameters), giving a **chart with the breakdown of LCOE** into chain components;
- Section 6.5: assess (with justifications) which of the pre-processing and conversion improvements present the **largest potential improvements** in overall chain cost, performance and emissions, and hence quantify (realistic) future targets for key parameters. The discussion will give brief examples of how these improvements could be achieved (e.g. what technical changes are assumed).

Section 7 summarises and builds on **key qualitative criteria** collected from the D1 review report, such as technology status and issues, supply chain risks and barriers, UK actors and potential UK deployment opportunities:

- Section 7.1: discussion of technology specific criteria, such as technology status and key issues, and UK actors;
- Section 7.2: discussion of chain level criteria, including the issues and benefits of integrating the component technologies into one chain, supply chain risks and barriers, and potential UK deployment opportunities.

Section 8 provides the **final project recommendations**, identifying which pre-processing technologies could most improve UK biomass supply chains and hence potentially lead to increased bioenergy deployment, and hence which routes should be the focus of (short and/or longer term) supported acceleration activities. This uses a **“heat map” table** to show how the various quantitative and qualitative criteria assessed compare across all the chains.

3.1 Material included and excluded

We have selected the most relevant charts and tables produced during the analysis for inclusion in the report. This required E4tech’s judgement to not simply provide the analysis for all charts, all metrics and all chains, but instead only focus on those charts and tables that offer the most insights. This means avoiding repetition where possible, prioritising information on LCOE where the emissions and efficiency charts tell the same story, and focusing on those most interesting charts (rather than e.g. hundreds of charts that do not show cross-overs). This decision making process took place during a series of working sessions between E4tech, CMCL and PSE during summer 2017. For each chart or table they produced, CMCL and PSE wrote up the accompanying interpretation of their findings under instructions from E4tech, with E4tech also taking the lead on messaging for each section, and the overall report structure.

3.2 Integration of gPROMS model with MoDS

The Model Development Suite (MoDS) software can be used to solve several model development and analysis problems, including generating and running experimental designs, and model calibration and optimisation. CMCL successfully linked the process libraries of gPROMS with the MoDS software, to allow multiple runs and analysis of the gPROMS model to take place.

Within this project, MoDS’s one-factor-at-a-time experimental design feature has been used both to analyse the effect of setting each input parameter to its minimum and maximum values and to perform parameter sweeps, where the other parameters are held at their base case values. The pie charts shown in Section 4.5 were generated from the results of the simulations run at the minimum and maximum input parameter values. The spider charts in Section 4.6 were generated using the full sweeps. The minimum and maximum sampling has also played a crucial role in testing the validity of the underlying model by allowing us to observe the effect of increasing/decreasing each parameter on the key output metrics.

MoDS is capable of setting up, running and collating the results of thousands of gPROMS model evaluations quickly and efficiently, whilst varying the values of the model’s input parameters. By simultaneously running chains that share a conversion technology, MoDS also ensures that the

results are comparable between the chains. This was important for generating the uncertainty scatters shown on the crossover charts in Section 5.1. The flexibility of MoDS also made it easy to perform the required low discrepancy sampling of the uncertain parameters, varying all parameters simultaneously, whilst also varying a single important user-defined parameter.

4 Sensitivity analysis

This section will explain the chain architectures and parameter ranges chosen, before highlighting which input parameters drive the modelling for each chain. These are the input parameters (technology characteristics, design choices, logistics) that should be focused on if an operator is trying to improve a technology or supply chain, in light of their ability to significantly influence important output metrics.

This sensitivity analysis is conducted by presenting the base case results for each chain, along with the pie charts (relative sensitivities) and spider charts (change in output metrics over the input parameter ranges) for each chain.

4.1 Chain architectures

Each supply chain starts with the input biomass feedstocks, and this biomass travels via a combination of various storage, transport and pre-processing steps, until it reaches the conversion technology, where electricity or heat are generated as outputs from the supply chain. A full description of how the supply chain models operate in gPROMS is given in the D5 User Guide.

The supply chains pre-loaded in gPROMS are highly functional, and contain the full set of TEABPP feedstocks as possible inputs, along with the possibility of setting a user-defined “other” feedstock. However, these pre-loaded chains are not useful for the required analysis in this D6 report, as they contain too many feedstocks being blended and too many parameters – issues which the TEABPP team proved prevent the generation of any insights into whether UK pre-processing can add value.

We therefore simplified the chain architectures used in the D6 analysis. One change was only having one blending module per chain (instead of two), in order to minimise the dilution of information from the pre-processing and upstream steps, but still include insights regarding blending costs and impacts in the analysis. Another change was only blending two biomass feedstocks³: Miscanthus, and a generic “Woody” feedstock that merges ETI’s Characterisation of Feedstocks (CoF) project data⁴ for the three similar woody feedstocks (SRF coniferous, SRF deciduous, SRC willow). Appendix B of the D5 User Guide shows that the biomass properties of these three woody feedstocks are sufficiently similar, and yet also sufficiently different to Miscanthus, to be appropriate to merge together⁵.

In Chains 4-10, the blending of feedstocks happens at the front end of the centralised pre-processing plant, and after upstream storage and transport of the individual feedstocks has already happened. The blending module is therefore only an extra arrival area and handling equipment for a new feedstock stream arriving at the pre-processing plant – it does not involve pre-mixing of the different

³ This approach also avoided having to replicate the whole sensitivity analysis four times for each feedstock on its own (and without any blending insights as required by ETI), or having to replicate the whole sensitivity analysis six times if pairs of feedstocks were blended, which would have required a significant reduction in the scope of the analysis conducted – or alternatively, also prevented two of the TEABPP feedstocks from being excluded from the analysis.

⁴ More information, including reports and data from the CoF project are available here: <http://www.eti.co.uk/programmes/bioenergy/characterisation-of-feedstocks>

⁵ The impact of merging these three feedstocks is relatively limited in the analysis, because the woody base case values are selected to match the SRF deciduous base case values, and despite “woody” having a wider min-max ranges for the biomass contaminants (i.e. potentially slightly higher sensitivities) than if each feedstock were considered individually, these min-max ranges are still realistic for any of the feedstocks (given their similarities, and CoF uncertainties). Even with the slightly enhanced sensitivities, the “woody” biomass contaminant parameters do not appear as key sensitivities in the results in any of the following sections.

feedstocks and storage of biomass at different densities and moisture contents (which would be problematic in terms of separation and self-heating issues). Due to the small scales and simple supply chains, Chains 1-3 do not blend the different biomass streams until being used in the final conversion plant – and these streams are all chips at reasonably low moisture contents (which will give rise to fewer issues). In other words, the blending step has zero storage time, and should be visualised as being merged with the following step.

The final architecture of each chain analysed is described in detail below in Section 4.3.

4.2 Selection of input parameter base cases and min-max ranges

Using the new chain architectures, E4tech and CMCL collected base case, minimum and maximum values for every input parameter modelled, with the values for the technologies identified by B&V, Sheffield and ICON. These ranges either define the current uncertainty within the parameters, or for the user-defined variables (that have no uncertainty) the extent to which the supply chains can be feasibly altered in the UK context (e.g. 0-100% blending fractions, 0-100% backhaul, 1-3 shifts/day, 5-15% discount rate, 0-800 km distances, 0-3 years storage).

The generic “woody” feedstock uses the widest union of ranges from the underlying SRC willow, SRF conifer and SRF deciduous feedstocks to derive its min-max ranges. Further details regarding the feedstock ranges used are given in the D5 User Guide, as these are a mix of ETI Characterisation of Feedstock project data, and ECN Phyllis2 data⁶.

Also, for pre-processing and conversion units, the ranges of some of the uncertain parameter inputs were widened by B&V, Sheffield and ICON to take into consideration possible future technology improvements (as discussed in Section 6.2). The assumptions behind each of these innovation improvements are given in the latest D2 Excel workbook, and the most important innovation improvements will be discussed further in Section 6.5.

The base cases are the key starting point in all the sensitivity and optimisation analysis that follows. The min-max ranges determine both how far the output metrics (net chain LCOE, emissions, efficiency) vary over each input parameter range (i.e. the global sensitivity), as well as the robustness of the cross-over results under uncertainty. Each parameter is labelled with a parameter name (that matches the gPROMS code), a sanitised parameter name (for plotting in this report), plus an important label for whether the parameter is a ‘user-defined variable’ (does not contribute to the uncertainty scatter in the cross-over charts) or an ‘uncertain parameter’ (does contribute to the uncertainty scatter). The full lists of input parameter base case, minimum and maximum values for each chain are provided in a separate Excel workbook “Inputs ranges with innovation”.

4.3 Base case results

Using the base case values chosen, PSE have generated output charts and tables from the gPROMS interface for the 10 chains, using the base case values for each input parameter⁷. This step was necessary to provide a deeper understanding of the key cost, performance and emissions values for

⁶ ECN (2017) “Phyllis 2”, available at: <https://www.ecn.nl/phyllis2/>

⁷ When outputting results, the gPROMS model does not calculate the optimum size of each component – it simply uses the user-defined scale, and does some very minor rescaling to get a whole number of units (e.g. the user-defined input of 100MW_e for a CFB combustion plant becomes a 99.48MW_e CFB combustion plant in order that there are exactly 27 of them to generate 20 TWh_e/yr at the calculated efficiency and availability, which both depend on the biomass characteristics).

each chain – i.e. how much more expensive (or cheaper) are the chains with pre-processing than their counterfactual chains without pre-processing, if only looking at the base case assumptions. These base case results also act as the starting point for all the subsequent analysis in the report.

Although the base case results do not provide direct information on parameter sensitivities, they nevertheless provide significant information on the relative importance of the different contributions (LCOE by unit, and by cost category) to the net LCOE for each chain, even if only locally. This is important context when proceeding to interpret the relative sensitivity of different parameters in the subsequent analysis.

The chain schematics and LCOE chain breakdown results are presented for each chain in turn, before the net chain LCOE, efficiency and GHG emissions metrics are compared in Section 4.4. Note that in the following schematics “SRF_decid” is the gPROMS name for the “Generic woody” feedstock in MoDS – i.e. the Generic woody feedstock is effectively modelled in MoDS by expanding the ranges for the SRF_decid feedstock in gPROMS, and setting the other gPROMS feedstocks to zero % blending. Further details of how the 10 chains were set up and run in gPROMS, including setting the required output of 20 TWh/yr of heat or power, are explained in the D5 User Guide.

4.3.1 Chain 1 – Underfeed stoker combustion boiler with screening

As shown in Figure 4.1, Chain 1 comprises feedstock harvesting and collection, screening (which includes an initial chipping step), natural drying of chips during shed storage, then truck transport to a local-scale underfeed stoker boiler (generating heat). The base case assumes 15 wet tonnes/hr screening, storage for 20 weeks, 20km trucking, and a 0.44MW_{th} boiler.

Chipping & Screening → Underfeed stoker

The following bioenergy chain schematic from the gPROMS interface shows the simplified Chain 1 architecture used for the sensitivity analysis.

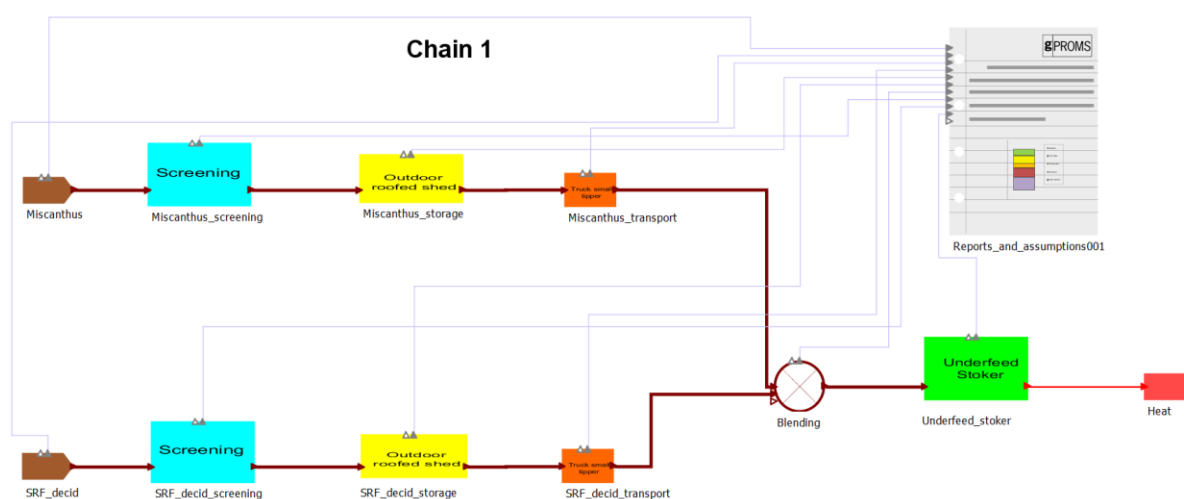

Figure 4.1: Chain 1 architecture in gPROMS

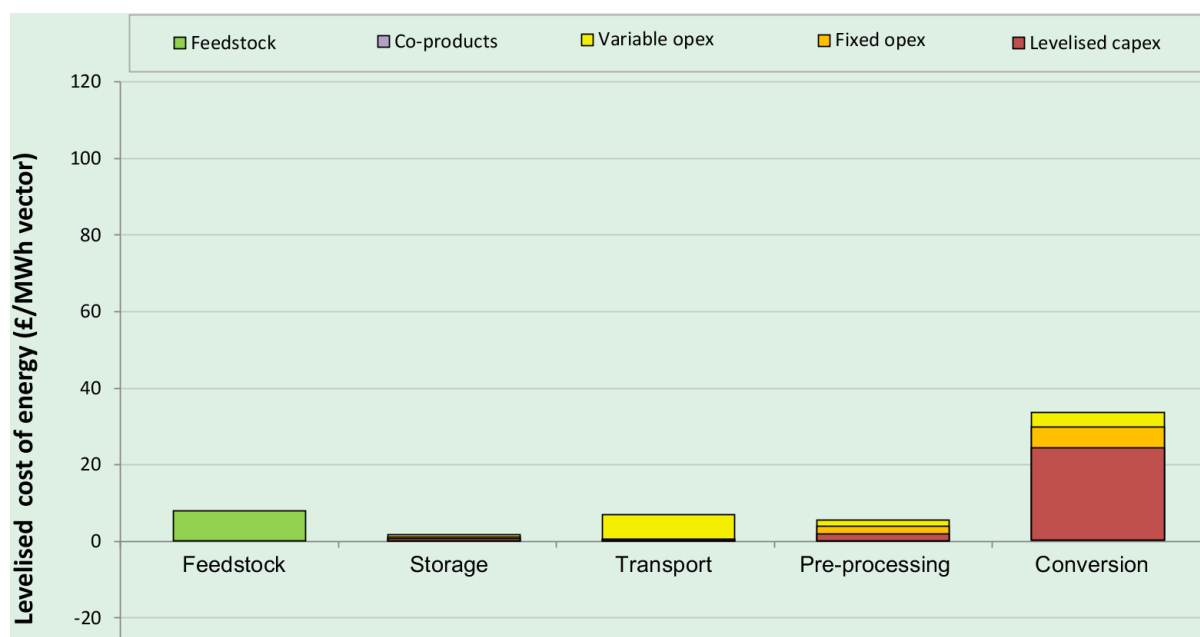

Figure 4.2: Chain 1 base case LCOE component breakdown

Table 4.1: Chain 1 base case LCOE component breakdown

| Costs (£/MWh _{th}) | Feedstock | Storage | Transport | Pre-processing | Underfeed stoker boiler | Total |
|------------------------------|------------|------------|------------|----------------|-------------------------|-------------|
| | | | | Screening | | |
| Feedstock | 7.4 | - | - | - | - | 7.4 |
| Co-products | - | - | - | 0 | - | 0.0 |
| Variable OPEX | - | 0.1 | 6.5 | 1.7 | 3.7 | 12.1 |
| Fixed OPEX | - | 0.3 | - | 2.1 | 5.5 | 8.0 |
| Levelised CAPEX | - | 0.7 | - | 1.4 | 23.9 | 26.0 |
| Total | 7.4 | 1.2 | 6.5 | 5.2 | 33.1 | 53.4 |

Figure 4.2 shows the component breakdown of the Chain 1 base case net chain LCOE. This highlights the importance of the heating conversion technology (underfeed stoker combustion boiler), which comprises roughly half of the chain’s total LCOE. In particular, the levelised CAPEX of the boiler accounts for over two thirds of the conversion costs. The other component costs further up the supply chain are much smaller by comparison, especially the storage costs (for a simple outdoor shed). Pre-processing costs are low, as the feedstock is only screened on the farm/in the forest, and transport costs are low due to the short transport distances assumed to a local boiler. Feedstock costs are a relatively modest contributor to the net chain LCOE, as the global gross efficiency (MWh of heat produced per MWh of biomass grown) of Chain 1 is high.

4.3.2 Chain 2 – Underfeed stoker combustion boiler with screening and field washing

As shown in Figure 4.3, Chain 2 comprises feedstock harvesting and collection, screening (which includes chipping), field washing, natural drying of chips during shed storage, then truck transport to a local-scale underfeed stoker boiler (generating heat). The base case assumes 15 wet tonnes/hr screening, 15 wet tonnes/hr field wash, storage for 20 weeks, 20km trucking, and a 0.44MW_{th} boiler.

Chipping & Screening → Field wash → Underfeed stoker

The following bioenergy chain schematic from the gPROMS interface shows the simplified Chain 2 architecture used for the sensitivity analysis.

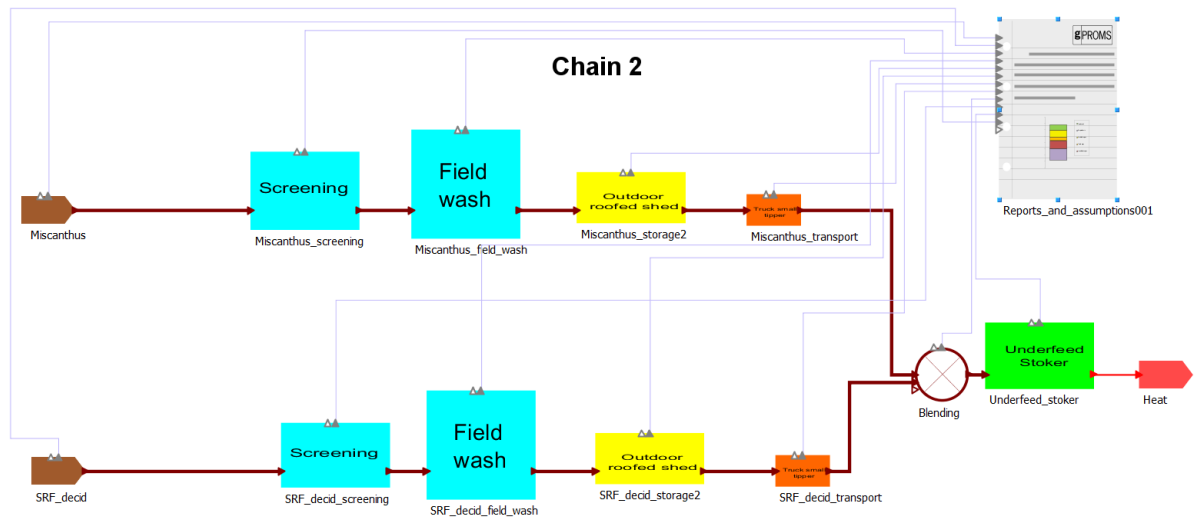

Figure 4.3: Chain 2 architecture in gPROMS

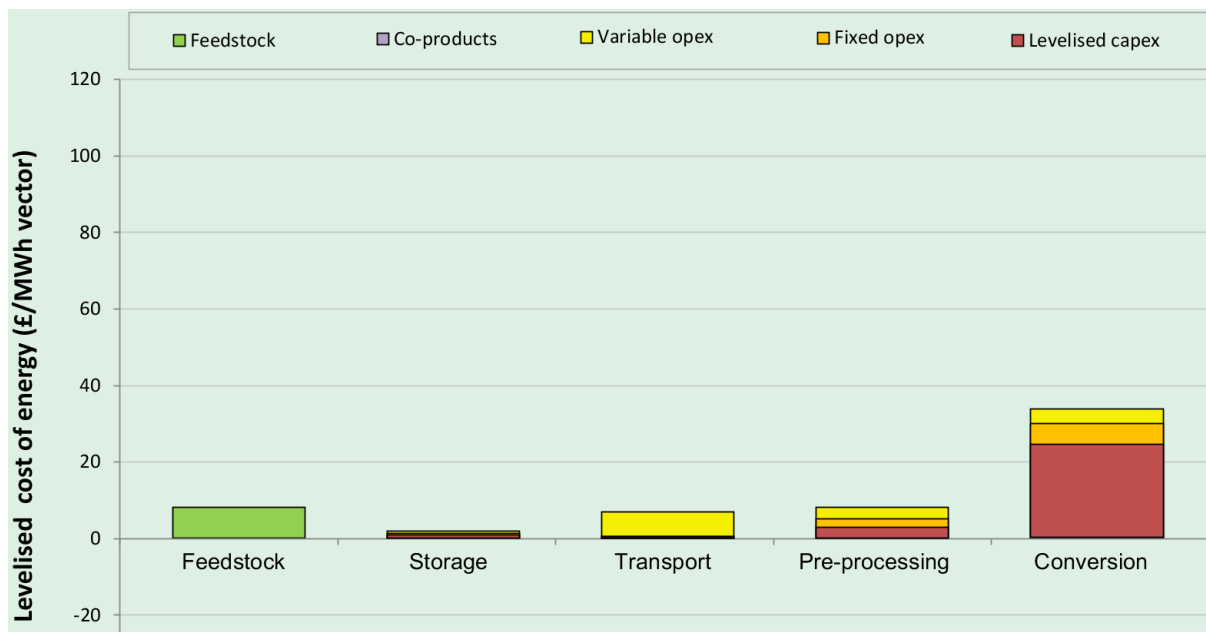

Figure 4.4: Chain 2 base case LCOE component breakdown

Table 4.2: Chain 2 base case LCOE component breakdown

| Costs (£/MWh _{th}) | Feedstock | Storage | Transport | Pre-processing | | Underfeed boiler | Total |
|------------------------------|------------|------------|------------|----------------|------------|------------------|-------------|
| | | | | Screening | Field wash | | |
| Feedstock | 7.7 | - | - | - | - | - | 7.7 |
| Co-products | - | - | - | 0 | 0 | - | 0.0 |
| Variable OPEX | - | 0.1 | 6.6 | 1.8 | 1.1 | 3.7 | 13.3 |
| Fixed OPEX | - | 0.4 | - | 2.2 | 0.2 | 5.6 | 8.4 |
| Levelised CAPEX | - | 0.8 | - | 1.4 | 1.0 | 24.0 | 27.3 |
| Total | 7.7 | 1.4 | 6.6 | 5.4 | 2.3 | 33.3 | 56.6 |

Figure 4.4 shows the component breakdown of the Chain 2 base case net chain LCOE. Compared to Figure 4.2, the conclusions for Chain 2 are very similar to Chain 1, demonstrating the importance of the heating conversion technology (underfeed stoker combustion boiler), which is roughly half of the chain's total LCOE. The conversion costs and efficiencies are similar, as although field washing reduces the feedstock ash and halide content, these benefits are offset by the increased feedstock moisture content as a result of the field washing.

The other upstream chain costs are still small, with pre-processing costs only marginally increased due to the addition of field washing on farm/in forest. Feedstock costs remain low due to high Chain 2 gross efficiency.

4.3.3 Chain 3 – BFB gasifier + syngas engine with screening

As shown in Figure 4.5, Chain 3 comprises feedstock harvesting and collection, natural drying during on-farm shed storage/tarp storage in-forest, screening (which includes an initial chipping step), followed by large truck transport to an intermediate scale BFB gasifier + syngas engine (generating power). The base case assumes 20 weeks storage for Miscanthus or 78 weeks for woody, then 15 wet tonnes/hr screening, 50km trucking, and a 5MW_{e (gross)} BFB gasifier + syngas engine.

Chipping & Screening → BFB gasifier + syngas engine

The following bioenergy chain schematic from the gPROMS interface shows the simplified Chain 3 architecture used for the sensitivity analysis.

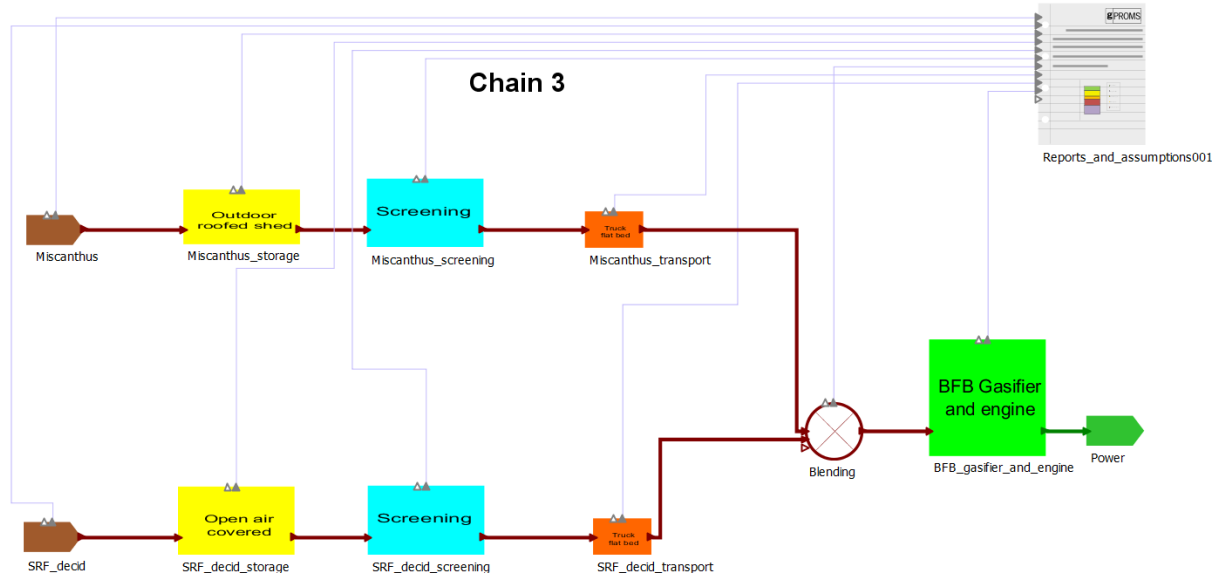

Figure 4.5: Chain 3 architecture in gPROMS

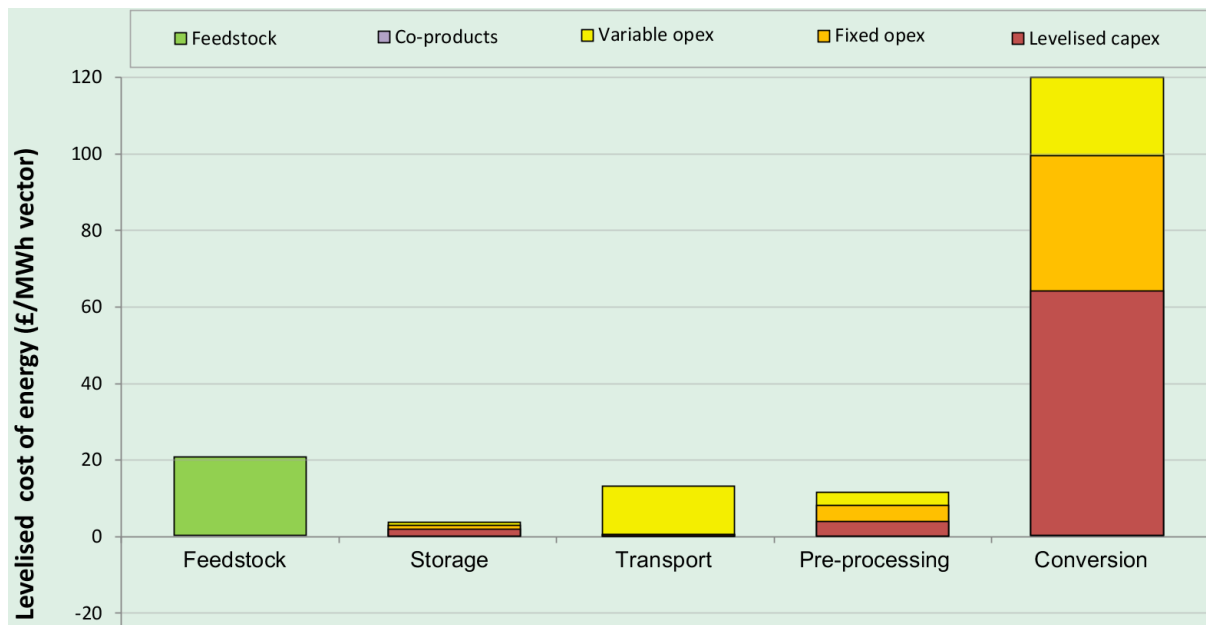

Figure 4.6: Chain 3 base case LCOE component breakdown

Table 4.3: Chain 3 base case LCOE component breakdown

| Costs (£/MW _e) | Feedstock | Storage | Transport | Pre-processing | BFB gasifier + syngas engine | Total |
|----------------------------|-------------|------------|-------------|----------------|------------------------------|--------------|
| | | | | Screening | | |
| Feedstock | 20.3 | - | - | - | - | 20.3 |
| Co-products | - | - | - | 0 | - | 0.0 |
| Variable OPEX | - | 0.4 | 12.7 | 3.4 | 20.5 | 37.1 |
| Fixed OPEX | - | 0.9 | - | 4.5 | 35.5 | 40.9 |
| Levelised CAPEX | - | 1.9 | - | 3.4 | 64.0 | 69.2 |
| Total | 20.3 | 3.2 | 12.7 | 11.3 | 120.0 | 167.5 |

Figure 4.6 shows the component breakdown of the Chain 3 base case net chain LCOE. This highlights the importance of the conversion technology (BFB gasifier + syngas engine), which is roughly two thirds of the chain’s total LCOE. In particular, the levelised CAPEX accounts for over half of the gasifier costs, with the fixed OPEX also contributing significantly. Upstream costs are still relatively small, due to limited pre-processing (screening), simple storage (outdoor sheds) and modest transport distances between the field/forest and the BFB gasifier. However, the feedstock costs are more prominent than in Chains 1 and 2, due to the low gross efficiency of Chain 3.

4.3.4 Chain 4 – BFB gasifier + syngas engine with water washing and pelleting

As shown in Figure 4.7, Chain 4 comprises feedstock harvesting and collection, natural drying during on-farm shed storage/tarp storage in-forest⁸, small truck transport to a water washing plant (which includes initial chipping and screening steps), natural drying of chips in a warehouse, then pelleting onsite before large truck transport to an intermediate scale BFB gasifier + syngas engine (generating power). The base case assumes 20 weeks storage for Miscanthus or 78 weeks for woody, then 30km trucking, 10 wet tonnes/hr water washing, 13 weeks warehouse storage, 14.3 wet tonnes/hr pelleting, 50km trucking, and a 5MW_{e (gross)} BFB gasifier + syngas engine.

Chipping & Screening & Water washing → Pelleting → BFB gasifier + syngas engine

The following bioenergy chain schematic from the gPROMS interface shows the simplified Chain 4 architecture used for the sensitivity analysis.

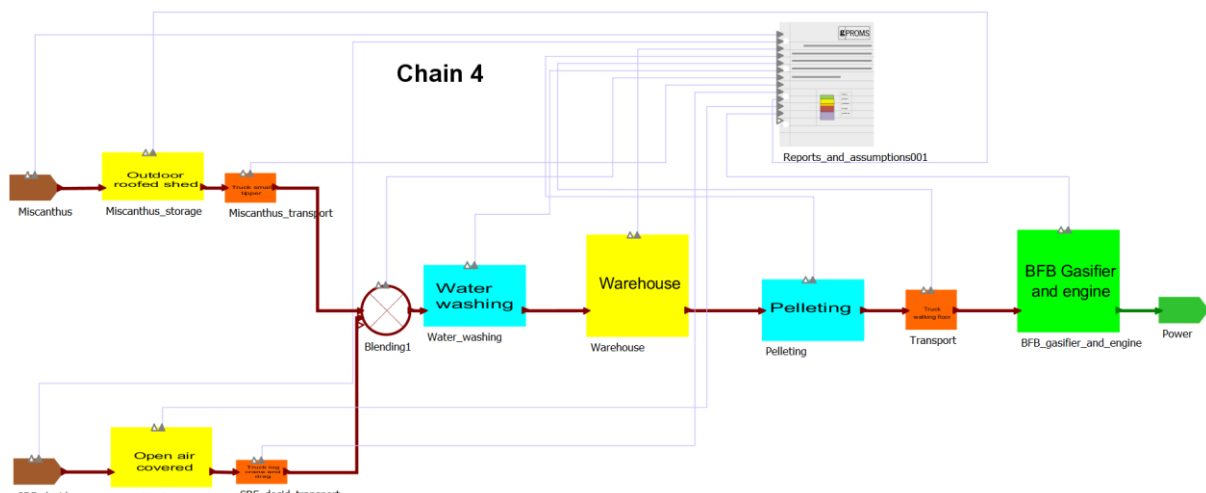

Figure 4.7: Chain 4 architecture in gPROMS

⁸ This initial storage step in Chain 4 is included to reduce feedstock transport costs and GHG emissions (less water moved), and to ensure consistency of chain architecture between Chains 3 and 4 (with sufficient storage times to allow for some of the seasonal variation in harvesting). Water washing only adds 10% moisture content to the biomass, so there is still value in the initial storage step reducing the starting moisture content of (in particular) the woody feedstocks, so we expect this to be reflective of expected practice.

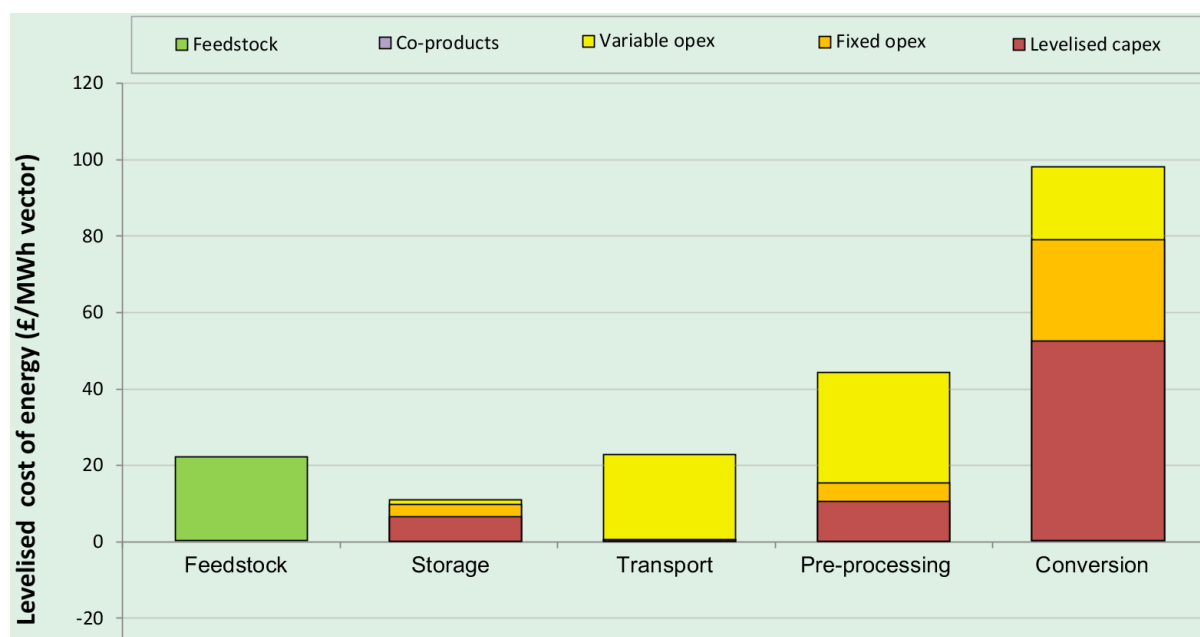

Figure 4.8: Chain 4 base case LCOE component breakdown

Table 4.4: Chain 4 base case LCOE component breakdown

| Costs (£/MWh _e) | Feedstock | Storage | Transport | Pre-processing | | BFB gasifier + syngas engine | Total |
|-----------------------------|-------------|-------------|-------------|----------------|-------------|------------------------------|--------------|
| | | | | Water wash | Pelleting | | |
| Feedstock | 21.8 | - | - | - | - | - | 21.8 |
| Co-products | - | - | - | 0 | 0 | - | 0.0 |
| Variable OPEX | - | 0.8 | 22.4 | 7.5 | 21.6 | 19.2 | 71.5 |
| Fixed OPEX | - | 3.1 | - | 2.5 | 2.5 | 26.7 | 34.8 |
| Levelised CAPEX | - | 6.5 | - | 4.3 | 5.8 | 52.2 | 68.8 |
| Total | 21.8 | 10.5 | 22.4 | 14.3 | 29.9 | 98.0 | 196.8 |

Figure 4.8 shows the component breakdown of the Chain 4 base case net chain LCOE. Compared to Figure 4.6, the conclusions for Chain 4 are somewhat different to Chain 3. The conversion technology (BFB gasifier + syngas engine) costs still dominate, but are reduced in Chain 4 by around £20/MWh_e due to the higher conversion efficiency (using dry, clean pellets instead of wet, dirty chips). However, Chain 4 has significantly higher pre-processing costs due to water washing and pelleting (particularly their variable OPEX components), compared to screening. Transport and storage costs are also higher, due to the extra transport step (and greater total distance travelled – despite this being of higher density pellets), in addition to the extra warehouse storage in Chain 4. Feedstock costs are relatively unchanged, as although the gasifier step is more efficient, the efficiency losses in the extra pre-processing steps offset this gain.

4.3.5 Chain 5 – CFB combustion boiler with screening

As shown in Figure 4.9, Chain 5 comprises feedstock harvesting and collection, natural drying during on-farm shed storage/tarp storage in-forest, small truck transport to a screening plant (includes an

initial chipping step), storage of chips in a warehouse, then large truck⁹ transport to a large-scale CFB combustion plant (generating power). The base case assumes 20 weeks storage for Miscanthus or 78 weeks for woody, then 30km trucking, 15 wet tonnes/hr screening, 13 weeks warehouse storage, 150km trucking, and a 100MW_e CFB combustion plant.

Chipping & Screening → CFB combustion

The following bioenergy chain schematic from the gPROMS interface shows the simplified Chain 5 architecture used for the sensitivity analysis.

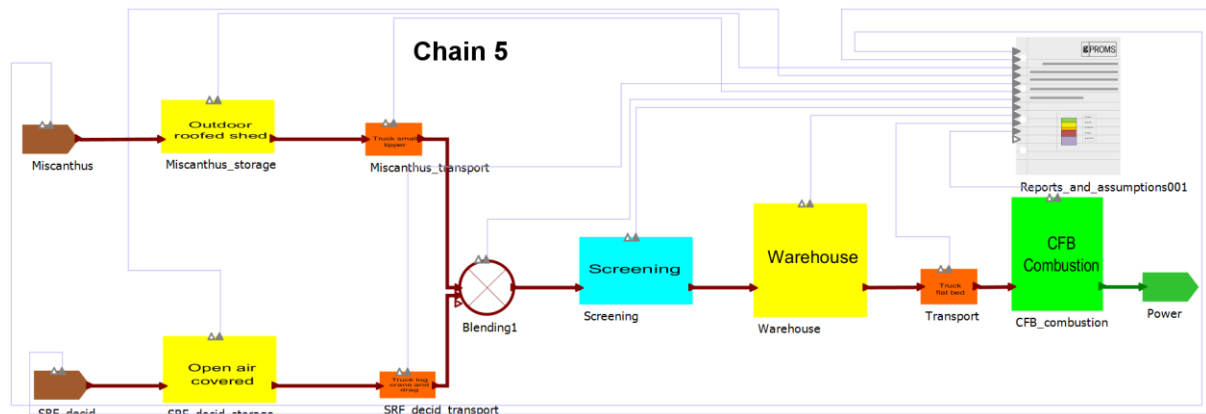

Figure 4.9: Chain 5 architecture in gPROMS

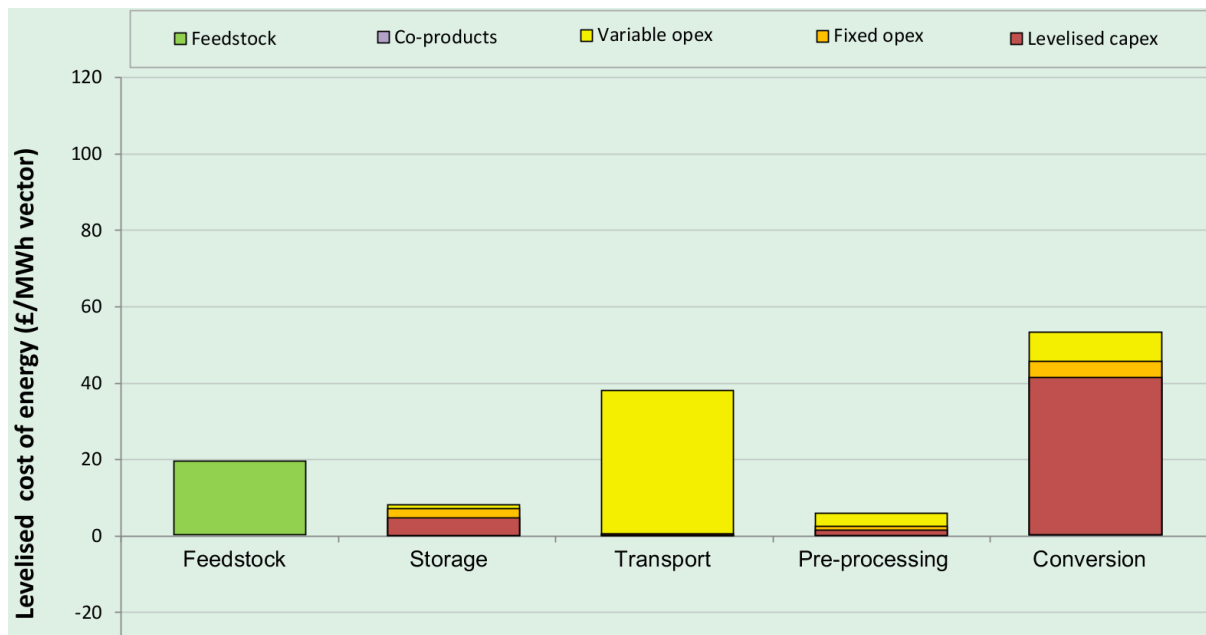

Figure 4.10: Chain 5 base case LCOE component breakdown

⁹ Note that Chain 5 assumes a flat-bed truck for the transport of chips, whereas Chains 6 & 7 assume walking-floor trucks for the transport of pellets. Chip transport could also use walking-floor trucks, with their quicker loading/unloading times, and this would reduce the Chain 5 transport costs by approximately £2/MWh_e.

Table 4.5: Chain 5 base case LCOE component breakdown

| Costs (£/MW _e) | Feedstock | Storage | Transport | Pre-processing | CFB combustion | Total |
|----------------------------|-------------|------------|-------------|----------------|----------------|--------------|
| | | | | Screening | | |
| Feedstock | 19.2 | - | - | - | - | 19.2 |
| Co-products | - | - | - | 0 | - | 0.0 |
| Variable OPEX | - | 0.8 | 37.8 | 3.3 | 7.6 | 49.4 |
| Fixed OPEX | - | 2.2 | - | 1.3 | 4.3 | 7.8 |
| Levelised CAPEX | - | 4.7 | - | 1.0 | 41.0 | 46.6 |
| Total | 19.2 | 7.7 | 37.8 | 5.5 | 52.9 | 123.1 |

Figure 4.10 shows the component breakdown of the Chain 5 base case net chain LCOE. This shows the importance of the CFB combustion boiler (particularly the levelised CAPEX, with the OPEX components contributing very little), along with the significant transport costs in Chain 5 (which are for low-density chips, but now for a much longer distance than in Chains 1-4). Other costs are relatively small, due to limited pre-processing (screening run at high availabilities), and simple storage (outdoor sheds or tarp covers, and a central warehouse) used in Chain 5. The feedstock costs are a modest contributor to Chain 5, as the gross efficiency of Chain 5 is not particularly high.

4.3.6 Chain 6 – CFB combustion boiler with pelleting

As shown in Figure 4.11, Chain 6 comprises feedstock harvesting and collection, natural drying during on-farm shed storage/tarp storage in-forest, small truck transport to a pelleting plant (which includes initial chipping and screening steps), pellet storage in a silo, then large truck transport to a large-scale CFB combustion plant (generating power). The base case assumes 20 weeks storage for Miscanthus or 78 weeks for woody, then 30km trucking, 14.3 wet tonnes/hr pelleting, 13 weeks silo storage, 150km trucking, and a 100MW_e CFB combustion plant.

Chipping & Screening & Pelleting → CFB combustion

The following bioenergy chain schematic from the gPROMS interface shows the simplified Chain 6 architecture used for the sensitivity analysis.

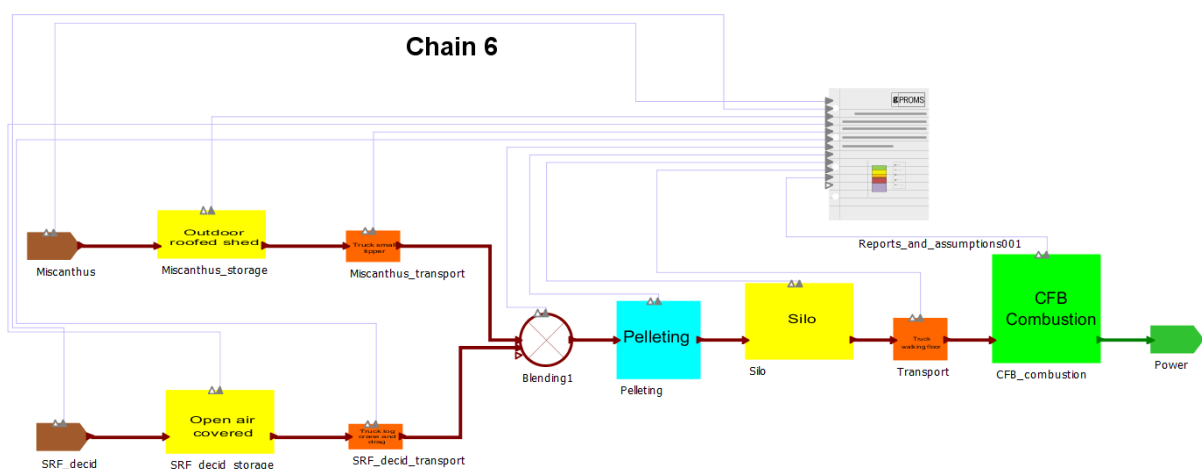

Figure 4.11: Chain 6 architecture in gPROMS

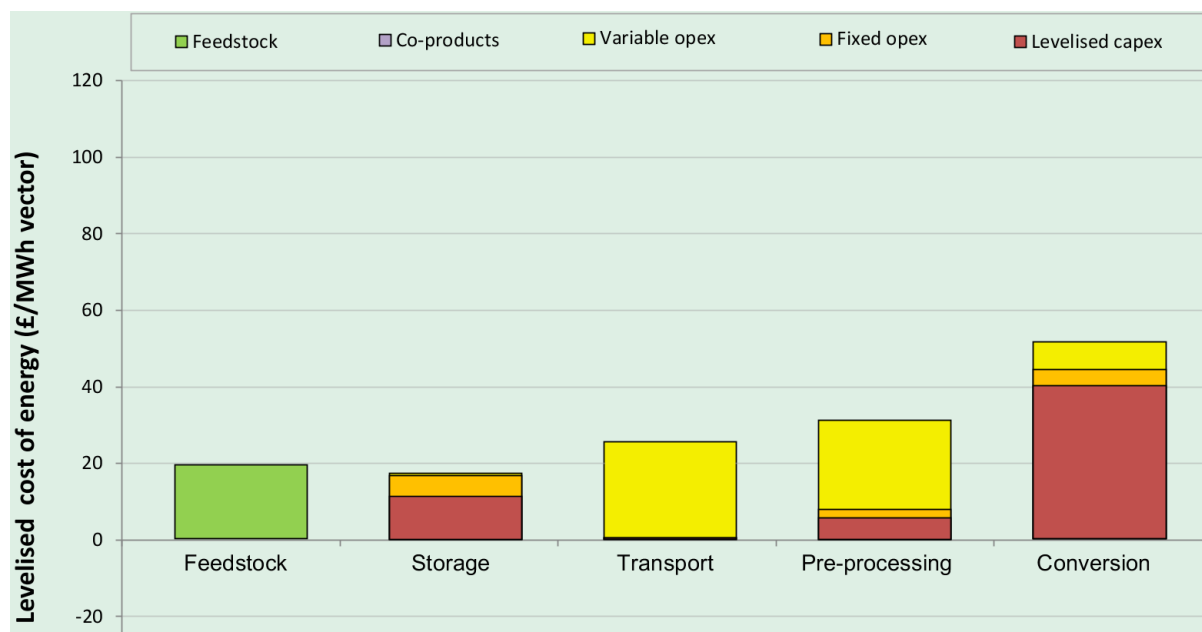

Figure 4.12: Chain 6 base case LCOE component breakdown

Table 4.6: Chain 6 base case LCOE component breakdown

| Costs (£/MWh _e) | Feedstock | Storage | Transport | Pre-processing | CFB combustion | Total |
|-----------------------------|-------------|-------------|-------------|----------------|----------------|--------------|
| | | | | Pelleting | | |
| Feedstock | 19.2 | - | - | - | - | 19.2 |
| Co-products | - | - | - | 0 | - | 0.0 |
| Variable OPEX | - | 0.5 | 25.4 | 23.4 | 7.3 | 56.6 |
| Fixed OPEX | - | 5.3 | - | 2.3 | 4.2 | 11.9 |
| Levelised CAPEX | - | 11.3 | - | 5.3 | 39.8 | 56.5 |
| Total | 19.2 | 17.1 | 25.4 | 31.1 | 51.3 | 144.2 |

Figure 4.12 shows the component breakdown of the Chain 6 base case net chain LCOE. Compared to Figure 4.10, the conclusions for Chain 6 are somewhat different to Chain 5. Firstly, the costs in Chain 6 are distributed more evenly across all the chain components, with no relatively insignificant components. The conversion technology (CFB combustion) costs still dominate, but are very slightly reduced in Chain 6 due to higher conversion efficiency (using dry, unwashed pellets instead of wetter, unwashed chips). However, compared to screening, the pelleting in Chain 6 has significantly higher pre-processing costs (particularly its variable OPEX, due to power consumption). Chain 6 storage costs are also higher due to use of silos (particularly the silo CAPEX). However, Chain 6 transport costs are significantly reduced due to moving high density pellets instead of chips in Chain 5, and the use of walking floor instead of flatbed trucks¹⁰. Feedstock costs are relatively unchanged, as the pelleting losses and CFB combustion gains are similar.

¹⁰ As discussed above, if Chain 5 were to also use walking-floor trucks instead of flatbed trucks, the Chain 5 transport costs could be approximately £2/MWh_e lower than the current base case. Therefore, the large majority of the difference in transport costs between Chain 5 and Chain 6 is due to the difference in the biomass density (chip vs. pellets), and not the difference choice of truck type.

4.3.7 Chain 7 – CFB combustion boiler with chemical washing and pelleting

As shown in Figure 4.13, Chain 7 comprises feedstock harvesting and collection, natural drying during on-farm shed storage/tarp storage in-forest¹¹, small truck transport to a chemical washing plant (which includes initial chipping and screening steps), natural drying of chips in a warehouse, then pelleting and pellet silo storage, before large truck transport to a large-scale CFB combustion plant (generating power). The base case assumes 20 weeks storage for Miscanthus or 78 weeks for woody, then 30km trucking, 10 wet tonnes/hr chemical washing, 13 weeks warehouse storage, 14.3 wet tonnes/hr pelleting, 13 weeks silo storage, 150km trucking, and a 100MW_e CFB combustion plant.

Chipping & Screening & Chemical washing → Pelleting → CFB combustion

The following bioenergy chain schematic from the gPROMS interface shows the simplified Chain 7 architecture used for the sensitivity analysis.

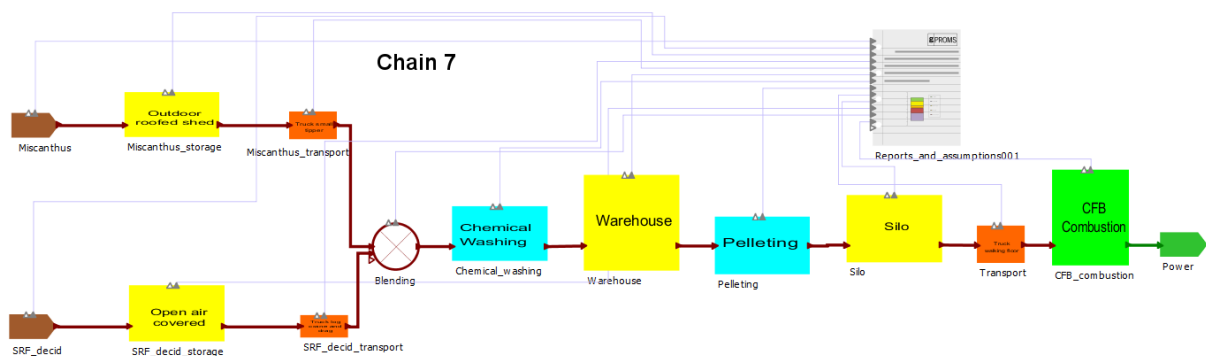

Figure 4.13: Chain 7 architecture in gPROMS

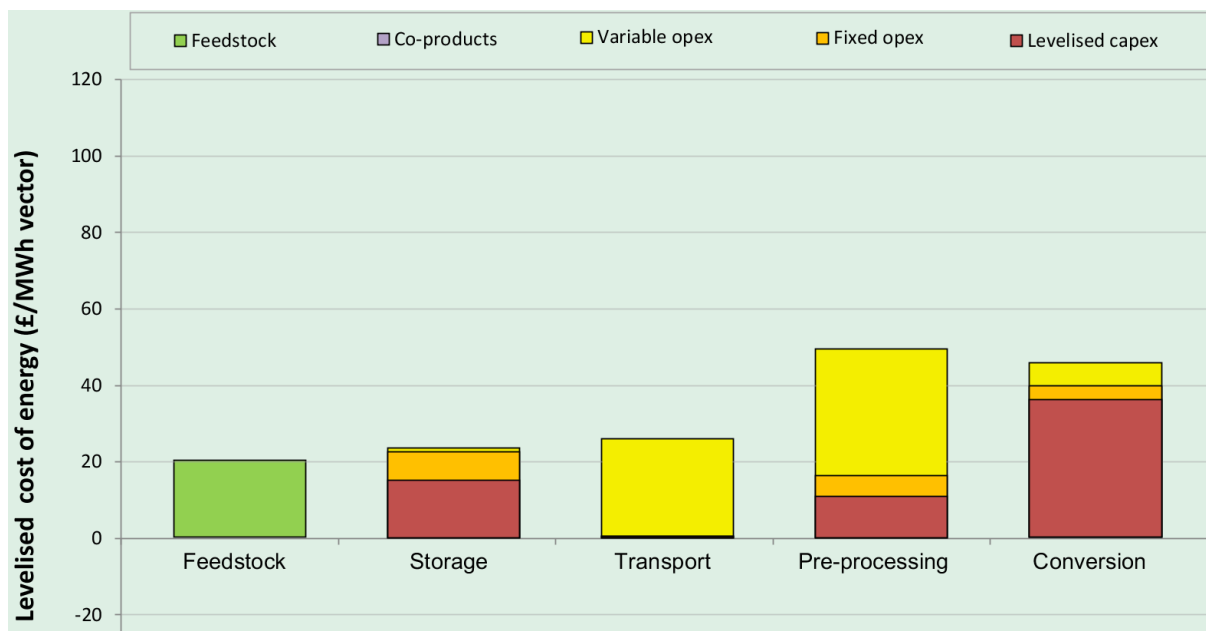

Figure 4.14: Chain 7 base case LCOE component breakdown

¹¹ This initial storage step in Chain 7 is included to reduce feedstock transport costs and GHG emissions (less water moved), and to ensure consistency of chain architecture between Chains 5, 6 and 7 (with sufficient storage times to allow for some of the seasonal variation in harvesting). However, chemical washing soaks the biomass to at least 50% moisture content, so there might be opportunities for the user to explore different architectures that do not have initial storage.

Table 4.7: Chain 7 base case LCOE component breakdown

| Costs (£/MWh _e) | Feedstock | Storage | Transport | Pre-processing | | CFB combustion | Total |
|-----------------------------|-------------|-------------|-------------|----------------|-------------|----------------|--------------|
| | | | | Chemical wash | Pelleting | | |
| Feedstock | 19.9 | - | - | - | - | - | 19.9 |
| Co-products | - | - | - | 0 | 0 | - | 0.0 |
| Variable OPEX | - | 0.8 | 25.7 | 13.6 | 19.6 | 5.9 | 65.7 |
| Fixed OPEX | - | 7.2 | - | 3.2 | 2.3 | 3.7 | 16.4 |
| Levelised CAPEX | - | 15.2 | - | 5.3 | 5.3 | 35.8 | 61.6 |
| Total | 19.9 | 23.2 | 25.7 | 22.2 | 27.2 | 45.4 | 163.6 |

Figure 4.14 shows the component breakdown of the Chain 7 base case net chain LCOE. This shows a somewhat similar picture to Figure 4.12, but with significantly higher pre-processing costs, due to the addition of chemical washing, which are now the largest cost component in the chain LCOE. The conversion technology (CFB combustion) costs no longer dominate, and are slightly reduced in Chain 7 due to slightly higher conversion efficiency and lower variable OPEX (due to using washed, dry pellets instead of unwashed, dry pellets in Chain 6). Feedstock and transport costs are relatively unchanged from Chain 6, whereas storage costs have increased slightly due to the addition of warehouse storage between chemical washing and pelleting.

4.3.8 Chain 8 – EF gasifier + syngas CCGT with pelleting

As shown in Figure 4.15, Chain 8 comprises feedstock harvesting and collection, natural drying during on-farm shed storage/tarp storage in-forest, small truck transport to a pelleting plant (which includes initial chipping and screening steps), pellet storage in a silo, then large truck transport to a very large-scale EF gasifier + syngas CCGT (generating power). The base case assumes 20 weeks storage for Miscanthus or 78 weeks for woody, then 30km trucking, 14.3 wet tonnes/hr pelleting, 13 weeks silo storage, 150km trucking, and a 300MW_{e (gross)} EF gasifier + syngas CCGT.

Chipping & Screening & Pelleting → EF gasifier + syngas CCGT

The following bioenergy chain schematic from the gPROMS interface shows the simplified Chain 8 architecture used for the sensitivity analysis.

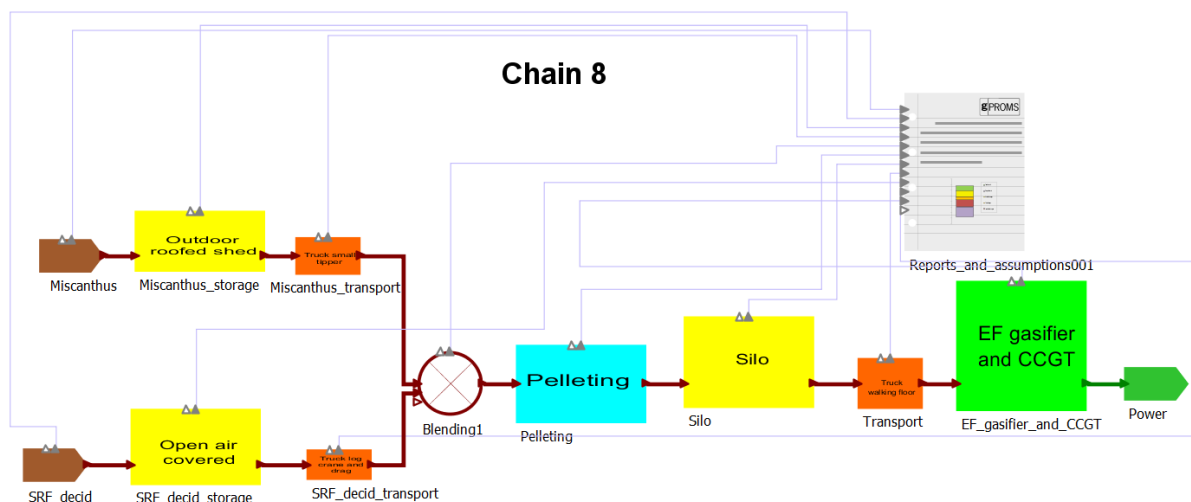

Figure 4.15: Chain 8 architecture in gPROMS

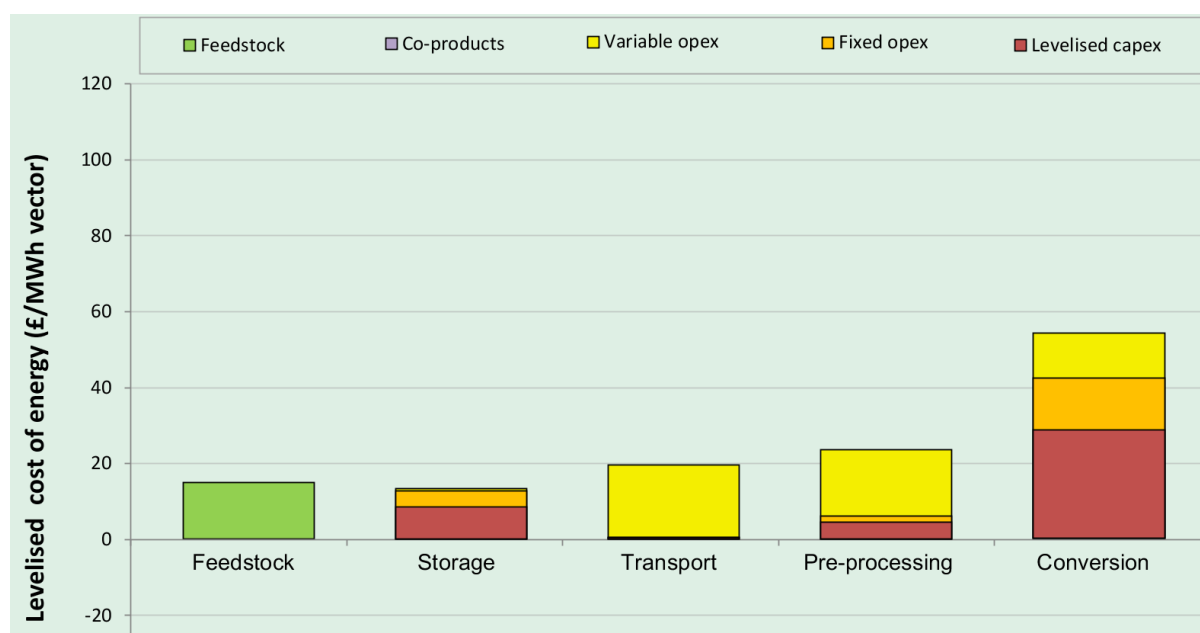

Figure 4.16: Chain 8 base case LCOE component breakdown

Table 4.8: Chain 8 base case LCOE component breakdown

| Costs (£/MWh _e) | Feedstock | Storage | Transport | Pre-processing | EF gasifier + syngas CCGT | Total |
|-----------------------------|-------------|-------------|-------------|----------------|---------------------------|--------------|
| | | | | Pelleting | | |
| Feedstock | 14.5 | - | - | - | - | 14.5 |
| Co-products | - | - | - | 0 | - | 0.0 |
| Variable OPEX | - | 0.4 | 19.2 | 17.7 | 12.0 | 49.3 |
| Fixed OPEX | - | 4.0 | - | 1.8 | 13.7 | 19.4 |
| Levelised CAPEX | - | 8.5 | - | 4.0 | 28.3 | 40.9 |
| Total | 14.5 | 12.9 | 19.2 | 23.4 | 54.0 | 124.1 |

Figure 4.16 shows the component breakdown of the Chain 8 base case net chain LCOE. The conversion technology (EF gasifier + CCGT) costs make up the largest share of the chain costs, with

the levelised CAPEX constituting only approximately half of the conversion step costs (as the other conversion OPEX fractions are significant). Otherwise, the spread of the chain costs is somewhat similar to that in Figure 4.12, given the similar transport distances, storage times, storage types and pelleting to Chain 6. However, in general the upstream costs (including feedstock costs) are slightly lower than in Chain 6, due to the higher gross efficiency of Chain 8 (due to the higher conversion efficiency of the large-scale EF gasifier + CCGT plant).

4.3.9 Chain 9 – EF gasifier + syngas CCGT with torrefaction + pelleting

As shown in Figure 4.17, Chain 9 comprises feedstock harvesting and collection, natural drying during on-farm shed storage/tarp storage in-forest, small truck transport to a torrefaction + pelleting plant (which includes initial chipping and screening steps), torrefied pellet storage in a silo, then large truck transport to a very large-scale EF gasifier + syngas CCGT (generating power). The base case assumes 20 weeks storage for Miscanthus or 78 weeks for woody, then 30km trucking, 10 odt/hr torrefaction+pelleting, 13 weeks silo storage, 150km trucking, and a 300MW_{e (gross)} EF gasifier + syngas CCGT.

Chipping & Screening & Torrefaction + Pelleting → EF gasifier + syngas CCGT

The following bioenergy chain schematic from the gPROMS interface shows the simplified Chain 9 architecture used for the sensitivity analysis.

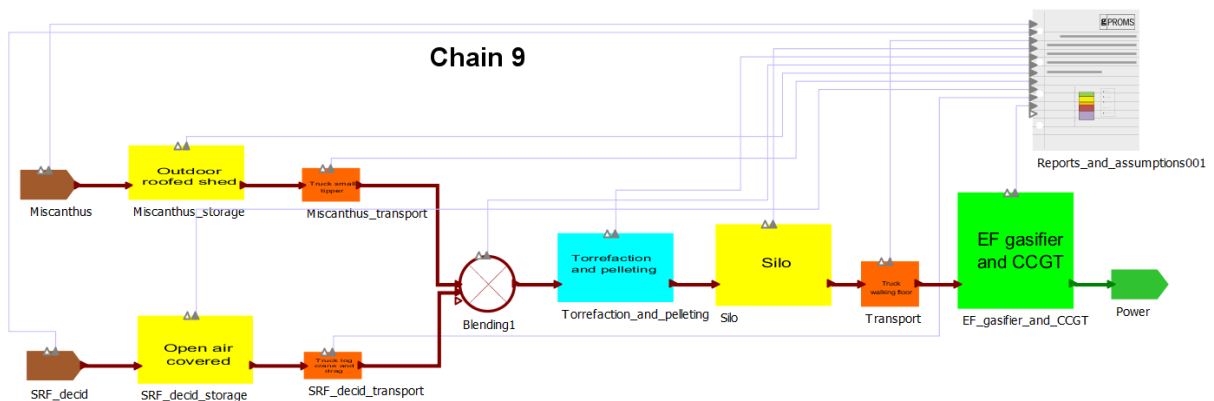

Figure 4.17: Chain 9 architecture in gPROMS

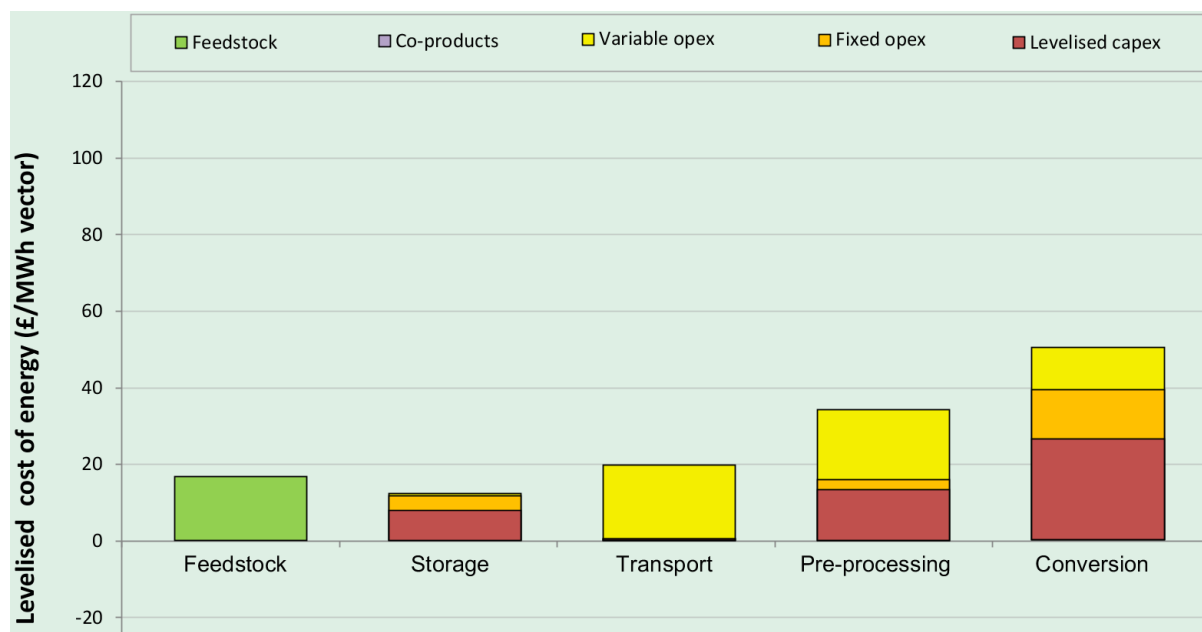

Figure 4.18: Chain 9 base case LCOE component breakdown

Table 4.9: Chain 9 base case LCOE component breakdown

| Costs (£/MWh _e) | Feedstock | Storage | Transport | Pre-processing | EF gasifier + syngas CCGT | Total |
|-----------------------------|-------------|-------------|-------------|--------------------------|---------------------------|--------------|
| | | | | Torrefaction + pelleting | | |
| Feedstock | 16.3 | - | - | - | - | 16.3 |
| Co-products | - | - | - | 0 | - | 0.0 |
| Variable OPEX | - | 0.4 | 19.5 | 18.4 | 11.0 | 49.3 |
| Fixed OPEX | - | 3.7 | - | 2.6 | 13.0 | 19.3 |
| Levelised CAPEX | - | 7.8 | - | 13.0 | 26.1 | 46.9 |
| Total | 16.3 | 11.9 | 19.5 | 34.0 | 50.1 | 131.9 |

Figure 4.18 shows the component breakdown of the Chain 9 base case net chain LCOE. As in Chain 8, the conversion technology (EF gasifier + CCGT) costs make up the largest share of the chain costs, with the levelised CAPEX constituting only approximately half of the conversion step costs (as the other conversion OPEX fractions are significant). However, the conversion costs are slightly lower in Chain 9 than in Chain 8, due to the higher EF gasifier efficiency (by using very dry torrefied pellets that grind easily, compared to wetter standard pellets that take significant parasitic electricity input to grind). Pre-processing costs are higher, particularly the levelised CAPEX component, due to the addition of torrefaction to Chain 9. Other chain costs, such as feedstock costs, storage and transport, are similar to Chain 9.

4.3.10 Chain 10 – EF gasifier + syngas CCGT with pyrolysis

As shown in Figure 4.19, Chain 10 comprises feedstock harvesting and collection, natural drying during on-farm shed storage/tarp storage in-forest, small truck transport to a pyrolysis plant (which includes an initial grinding step), pyrolysis oil storage in a tank, then large tanker transport to a very large-scale EF gasifier + syngas CCGT (generating power). The base case assumes 20 weeks storage

for Miscanthus or 78 weeks for woody, then 30km trucking, 10 odt/hr pyrolysis, 13 weeks tank storage, 150km tanker trucking, and a 300MW_{e (gross)} EF gasifier + syngas CCGT.

Grinding & Pyrolysis → EF gasifier + syngas CCGT

The following bioenergy chain schematic from the gPROMS interface shows the simplified Chain 10 architecture used for the sensitivity analysis.

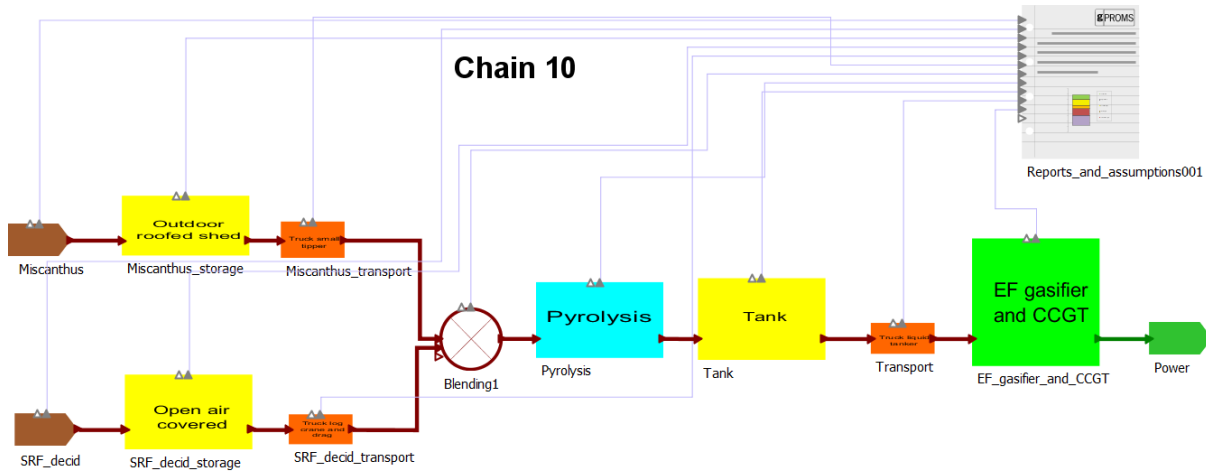

Figure 4.19: Chain 10 architecture in gPROMS

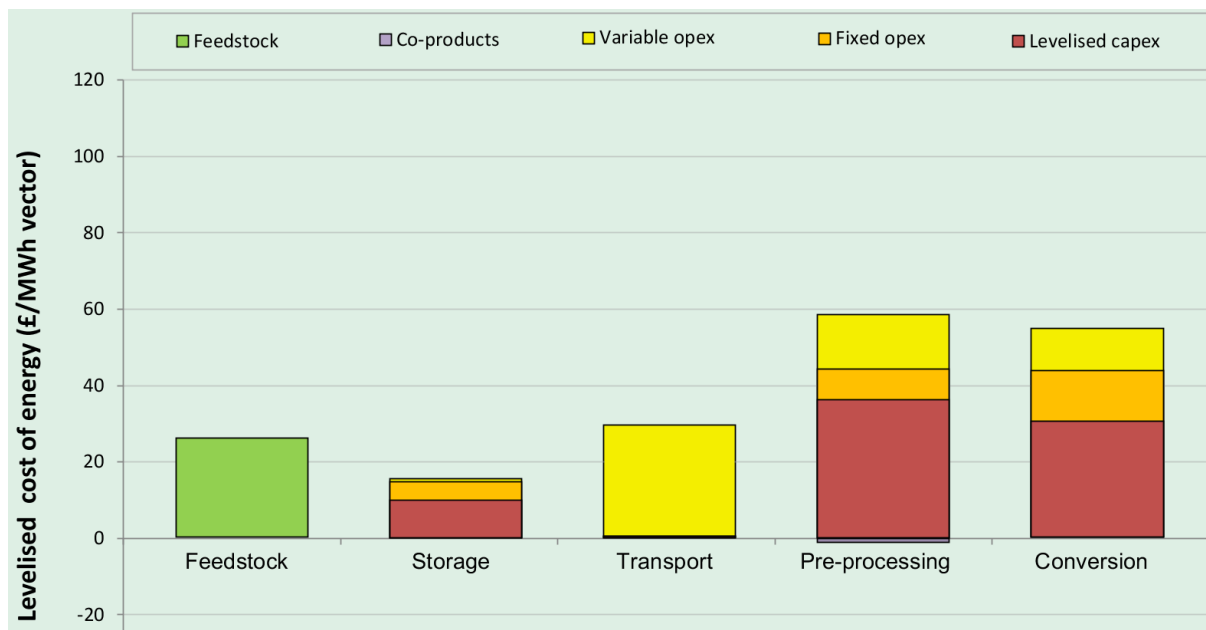

Figure 4.20: Chain 10 base case LCOE component breakdown

Table 4.10: Chain 10 base case LCOE component breakdown

| Costs (£/MWh _e) | Feedstock | Storage | Transport | Pre-processing | EF gasifier + syngas CCGT | Total |
|-----------------------------|-------------|-------------|-------------|----------------|---------------------------|--------------|
| | | | | Pyrolysis | | |
| Feedstock | 25.7 | - | - | - | - | 25.7 |
| Co-products | - | - | - | -1.0 | - | -1.0 |
| Variable OPEX | - | 0.6 | 29.5 | 14.3 | 11.1 | 55.5 |
| Fixed OPEX | - | 4.7 | - | 8.2 | 13.4 | 26.2 |
| Levelised CAPEX | - | 9.9 | - | 36.1 | 30.1 | 76.1 |
| Total | 25.7 | 15.2 | 29.5 | 57.5 | 54.6 | 182.5 |

Figure 4.20 shows the component breakdown of the Chain 10 base case net chain LCOE. This highlights the importance of the pyrolysis costs in this chain, especially the levelised CAPEX, which are significantly higher than the pre-processing options used in Chains 8 and 9. The conversion costs (for EF gasifier + CCGT) are relatively unchanged compared to the costs in Chain 8 (as shown in Figure 4.16). The feedstock and transport costs have increased, due to the lower gross efficiency of Chain 10, due to the significant efficiency loss during pyrolysis. The storage costs have increased only slightly from Chain 8, due to the chain efficiency loss being moderated by the tank storage being slightly cheaper per MWh than a silo.

4.4 Summary of base case findings

Table 4.11 compares the key output metrics for all ten chains, with the results generated using the base case values of every input parameter. Note that the analysis below the table applies only to these base case results for the chain architectures selected, and may not universally apply across the whole parameter space (e.g. the findings could be very different if the chains were optimised as in Section 6.3, or different base cases or architectures were selected). As a reminder, the chain gross efficiency is the MWh of electricity or heating generated, divided by the MWh of feedstock collected. The chain net efficiency is the gross efficiency minus energy inputs to the chain, such as power, diesel or natural gas.

The GHG methodology and system boundary used to calculate the chain GHG emissions is the same as defined under the RHI/RO GHG reporting guidance. The chain GHG emissions therefore exclude indirect land use change emissions, and for simplicity do not assume any direct land use changes or carbon stock changes have occurred. The chain GHG emissions include feedstock establishment, cultivation and harvesting (via a feedstock production GHG parameter input at the TEABPP model boundary), with storage, transport, pre-processing, and conversion step emissions then all modelled explicitly within TEABPP. Losses from electricity transmission & distribution are not considered, nor are thermal losses in hot water distribution – i.e. the supply chain ends at the output sold from the conversion plant.

Table 4.11: Comparison of base case results for the 10 chains

| Chain | LCOE (£/MWh) | Net efficiency (%) | Gross efficiency (%) | GHG emissions (kgCO ₂ e/MWh) |
|--|--------------------|--------------------|----------------------|---|
| 1 - screen, boiler (<i>heat</i>) | 53 _[th] | 78.9 | 83.1 | 33 _[th] |
| 2 - screen, field wash, boiler (<i>heat</i>) | 57 _[th] | 76.1 | 80.8 | 37 _[th] |
| 3 - screen, BFB gasify | 172 _[e] | 24.0 | 27.9 | 87 _[e] |
| 4 - water wash, pellet, BFB gasify | 197 _[e] | 18.1 | 25.9 | 175 _[e] |
| 5 - screen, CFB combust | 123 _[e] | 26.3 | 31.6 | 89 _[e] |
| 6 - pellet, CFB combust | 144 _[e] | 23.4 | 31.6 | 147 _[e] |
| 7 - chem wash, pellet, CFB combust | 164 _[e] | 22.0 | 30.5 | 199 _[e] |
| 8 - pellet, EF gasify | 124 _[e] | 29.8 | 38.0 | 122 _[e] |
| 9 - torrefy+pellet, EF gasify | 132 _[e] | 26.3 | 34.1 | 135 _[e] |
| 10 - pyrolysis, EF gasify | 182 _[e] | 17.9 | 21.7 | 100 _[e] |

Compared to Chains 3 – 10, Chains 1 and 2 have high efficiencies, low costs and low GHG emissions, due to using local supply chains to only generate heat (hence figures given are per MWh_{th}, as indicated by the _[th]). By contrast, Chains 3 – 10 use longer supply chains and only generate power¹² (for which figures are given in per MWh_e, as indicated by the _[e]). Chains 1 and 2 therefore need to be analysed separately to Chains 3 – 10.

For the chains that produce heat via an underfeed stoker boiler (Chains 1 and 2), the addition of field washing technology (to achieve a cleaner feedstock) is unable to reduce the boiler costs enough to offset the extra costs of the field washing technology. Moreover, there is a modest decrease in the overall net chain efficiency, due to the decrease in biomass LHV caused by the gain in moisture from the washing process, as well the addition of electricity required for the field washing. The same factors lie behind the modest increase in chain GHG emissions, but both chains would be well within the current UK thresholds for chain GHG emissions were the boiler operators applying for the Renewable Heat Incentive¹³.

Comparing the chains which use a BFB gasifier + syngas engine conversion technology (Chains 3 and 4), the addition of the water washing and pelleting technologies in Chain 4 does lead to a noticeable decrease in the conversion costs. However, there is a sizeable increase in the pre-processing costs, which more than offsets the reduction in conversion costs, leading to the increased costs of Chain 4 seen in Table 4.11 above (Chain 4 is actually the most expensive power generation chain in TEABPP). The gross efficiency of Chain 4 is lower than Chain 3 by about 2%, due to losses during water washing and pelleting more than offsetting the conversion efficiency gains from using dry pellets. The net efficiency of Chain 4 is 5.9% lower than Chain 3, due to the extra energy requirements in water washing and pelleting (particularly power consumption), as well as the additional transport fuel consumed for the longer distance. As a result of these extra inputs and the slightly lower gross

¹² Note that the use of waste heat for e.g. district heating could be an option for some these power generation technologies. Combined heat and power (CHP) plants therefore might be able to improve chain economics and GHG emissions, through allocation of some of the costs and GHG emissions to the heat. However, the net impacts would depend strongly on the heat demand profile and temperatures, heat revenues, scales, CHP vs. power only plant efficiencies and costs. Analysis of CHP chains was not within the scope of the TEABPP project, as CHP options were scoped out in early 2016, as reflected in the D3 report.

¹³ The current GHG emissions threshold under the RHI is 34.8 gCO₂e/MJ of heat, which equates to 125.3 kgCO₂e/MWh_{th}. Source: Ofgem (2017) "Sustainability self-reporting guidance", available at: https://www.ofgem.gov.uk/system/files/docs/2017/01/sustainability_self-reporting_guidance_jan_2017.pdf

chain efficiency, the GHG emissions for Chain 4 are double those of Chain 3 – the water washing and pelleting units alone account for 98 kgCO₂e/MWh_e, compared to screening in Chain 3 producing only 11 kgCO₂e/MWh_e. Chain 3 has the lowest GHG emissions (at the base case) of all of all the TEABPP power generation chains, due to the short transport distances and minimal chain inputs.

For the chains which use CFB combustion boiler conversion technology (Chains 5-7), adding more pre-processing (pelleting, and then additionally, chemical washing) does not reduce the conversion costs sufficiently to offset each increase in the pre-processing costs. Chain 5 using only screening remains the cheapest chain within this grouping (and the cheapest power generation chain overall in TEABPP at the base case conditions), while Chain 7 combining chemical washing and pelleting is the most expensive chain within this grouping. The gross chain efficiency for Chains 5 and 6 is equal; meaning roughly the same amount of feedstock is needed to generate the same amount of power. Chain 7 on the other hand has a smaller gross efficiency due to the drop in biomass LHV in the chemical washing unit. There is also a significant drop in net efficiency from Chain 5 to 6, and from Chain 6 to 7, as a result of the increasing energy input demands for the pre-processing technologies. These additional inputs and lower chain efficiencies lead to higher chain GHG emissions, with screening in Chain 5 only responsible for 9 kgCO₂e/MWh_e, whereas pelleting in Chain 6 accounts for 76 kgCO₂e/MWh_e, and chemical washing + pelleting in Chain 7 accounts for 121 kgCO₂e/MWh_e. The various chemical and power inputs result in Chain 7 having the highest GHG emissions of any TEABPP chain at the base case, and so some power plant operators applying for Renewable Obligation Certificates or operating under a Contract for Difference may struggle to comply with UK thresholds for GHG emissions post-2025 if using chemical washing¹⁴.

Comparing the group of chains which use an EF gasifier and CCGT turbine conversion unit (Chains 8-10), Chain 8 is the cheapest chain in this group, followed by Chain 9 (using torrefaction + pelleting), and Chain 10 is the most expensive chain in this group. Looking at the efficiencies, Chain 8 using pelleting has the highest gross and net efficiencies of any TEABPP power generation chain, whilst Chain 10 is the least efficient power generation chain in TEABPP (on both measures, gross and net efficiency). Chain 9 still has a relatively high overall efficiency, despite the addition of torrefaction. Whilst Chain 10 has the lowest efficiency, the inputs to this chain are small (e.g. the pyrolysis unit is self-sufficient), and hence Chain 10 has the lowest GHG emissions in this group. Chain 9 only has modestly higher GHG emissions than Chain 8, due to the slightly lower overall efficiency of Chain 9 plus the additional power use in torrefaction.

4.4.1 Warning flags raised at the base case

Warning flags are raised in gPROMS when the input biomass parameters to a module within a chain are above a specified maximum limit (or below a specified minimum limit). A warning flag means that chain operation is still possible, and gPROMS results for the chain are still calculated, but the input material to that module lies outside the usual operating range specified by the representative

¹⁴ New build dedicated biomass power plants (with or without CHP) need to meet 240 kgCO₂e/MWh_e from April 2014-March 2020, then 200 kgCO₂e/MWh_e from April 2020-March 2025, and then 180 kgCO₂e/MWh_e from April 2025-March 2030. This is set out in DECC (2013) "Government Response to the consultation on proposals to enhance the sustainability criteria for the use of biomass feedstocks under the Renewables Obligation (RO)", available at: https://www.gov.uk/government/uploads/system/uploads/attachment_data/file/231102/RO_Biomass_Sustainability_consultation_-_Government_Response_22_August_2013.pdf

equipment suppliers characterised within TEABPP¹⁵. Warning flags are therefore useful in highlighting where there is a risk that:

- the equipment lifetime or warranties could be compromised, and/or
- the gaseous emissions of PM, NO_x etc. might be higher than allowed permit limits, and/or
- the model parameterisations may no longer hold (i.e. relationships are being extrapolated too far from the original datasets, and the relationships are not as well understood beyond the warning flags), and/or
- a different conversion technology is required to be chosen in order to be able to use the feedstock, but this choice of suitable conversion technology may lie outside those represented in the TEABPP modelling¹⁶.

Therefore results from chains that raise warning flags should be treated with caution.

As a reminder, the parameterised relationships between biomass contaminants and conversion plant efficiency, opex and availability are summarised in the D3 report. Appendix A of the D5 report also sets out tables of which input parameters influence the capex, opex and efficiency of each conversion and pre-processing technology. Therefore across all the chains, additional costs are already incurred within the model as biomass contaminants increase. However, the additional costs (slopes and/or steps) parameterised in gPROMS do not necessarily kick in, jump or accelerate at each of the gPROMS warning flag limits – the additional cost formulae in D3 were derived separately to the warning flag limits for each technology.

Some biomass contaminants are also assumed to not have any impact on the chain results due to a lack of data, even though they have a warning flag limit in gPROMS (for example, Aluminium, Calcium). For some species such as Silicon, Bromine and Fluorine, their impact was agreed in D3 to already be sufficiently parameterised via another input parameter (respectively, Ash, Chlorine and Chlorine), so again these species do not impact the chain results, even though they have a warning flag limit in gPROMS.

Table 4.12 shows which warning flags are raised at the base case for each chain, which as a reminder uses a 50:50 mix of Miscanthus and Generic woody (SRF deciduous) feedstocks. These warning flags are only raised at the conversion technology steps (with all the flags shown due to exceeding maximum specified limits, not the minimum limits), as the majority of the conversion technologies are nominally designed for relatively clean, long rotation forestry feedstocks, rather than higher ash energy crops such as Miscanthus. No warning flags are raised at the pre-processing units.

For the comparator chains “without pre-processing” (Chains 1, 3, 5, 8), ETI selected these chains in the D3 report, before the CoF feedstock data was available – these chains were not “selected” by

¹⁵ Although much of the commercial technology data used in TEABPP was derived from number of suppliers, the universe of all possible equipment suppliers was not assessed, and so the representative technology data and feedstock limits in TEABPP were derived from the data available to the consortium. It is therefore entirely possible that some equipment manufacturers might be able to supply conversion technologies that do not raise warning flags – for example, heating boilers capable of using only unprocessed Miscanthus that are designed for high ash, chlorine and alkali metals. However, the costs and efficiencies of these different systems could be significantly different to the selected technologies modelled in TEABPP.

¹⁶ For example, if the user inputs biomass composition data into the gPROMS “other” feedstock module that corresponds to low quality waste wood or very high ash Miscanthus, it should not be surprising that the flags raised would indicate that conversion technologies specifically designed for using waste wood or high ash Miscanthus need to be chosen instead of those currently within TEABPP.

the gPROMS model. All of these chains raise warning flags, suggesting that there are risks of operating these chains with the selected base case feedstock blend.

As shown, only Chain 4 (with its water washing), Chain 7 (with its chemical washing) and Chain 10 (with pyrolysis) are able to clean the biomass far enough to avoid all the conversion technology flags within these chains. This suggests that although water washing, chemical washing and pyrolysis are unable to lower overall chain costs, these pre-processing technologies might be required by some plant operators to be able to use this base case mix of feedstocks, and yet still meet their performance guarantees, expected lifetimes and/or gaseous emissions permits.

Screening, field washing, pelleting or torrefaction+pelleting are unable to avoid the flags at the base case settings, as these pre-processing techniques are relatively mild, and without the ability to remove a significant fraction of the inherent biomass elements. Torrefaction is actually expected to increase the concentration of many elements, hence the additional warning flag in Chain 9.

Table 4.12: Warning flags raised in gPROMS at the base case for the 10 chains

| Chain | Unit where flags raised | Variables above their specified limit |
|--|-------------------------|--|
| 1 - screen, boiler (<i>heat</i>) | Underfeed stoker | Ash, alkali index, nitrogen, silicon, chlorine, potassium, sodium, calcium |
| 2 - screen, field wash, boiler (<i>heat</i>) | Underfeed stoker | Ash, alkali index, nitrogen, silicon, chlorine, potassium, sodium, calcium |
| 3 - screen, BFB gasify | BFB gasifier | Ash, chlorine, potassium |
| 4 - water wash, pellet, BFB gasify | (None) | - |
| 5 - screen, CFB combust | CFB combustor | Ash, chlorine, bromine, potassium |
| 6 - pellet, CFB combust | CFB combustor | Ash, chlorine, potassium |
| 7 - chem wash, pellet, CFB combust | (None) | - |
| 8 - pellet, EF gasify | EF gasifier | Chlorine |
| 9 - torrefy+pellet, EF gasify | EF gasifier | Chlorine, bromine |
| 10 - pyrolysis, EF gasify | (None) | - |

4.5 Pie chart sensitivities

Using the automated link between gPROMS and MoDS, CMCL have run the gPROMS model at the maximum and minimum values for each parameter in turn (including all the user-defined variables and all the uncertain parameters), holding the rest of the parameters at their base case. The change in the net chain LCOE, efficiency and emissions metrics at each maximum and minimum was then calculated, and reviewed by E4tech to check that the first pass of the sensitivity results made sense.

Using the delta in the key output metrics when varying between the maximum and minimum input values, CMCL calculated the absolute sensitivity for each input parameter individually. These sensitivities were then normalised for each key output metric (net chain total LCOE, efficiency and GHG emissions), and then plotted as a pie chart for each chain. This process visualises the relative importance of the parameter sensitivities to the model outcomes.

In each of the charts below, all of the input parameters were included for the simulations, but the pie charts only explicitly plot at least the top five most sensitive parameters plus all those parameters with a relative sensitivity of more than 5%. The “Other” segment represents the combined contribution of all of the less important parameters that are not explicitly plotted.

Note that every single one of the parameters plotted on the pie charts is an independent input, the value of which does not rely on any of the other parameters plotted. ‘Multipliers’ are parameters that sit at the start of some gPROMS formulae, and generally have a base case = 1.00. For example in Figure 4.22, the Underfeed stoker efficiency = Underfeed stoker efficiency multiplier * (other parameterisations involving the impact of feedstock moisture, ash, Cl, S, alkali index).

4.5.1 Chain 1 – Underfeed stoker combustion boiler with screening

As an explanation of how to read the first pie chart below (Figure 4.21) – it can be seen that the Miscanthus chips transport distance is the input parameter to which the Chain 1 LCOE is most sensitive. The relative sensitivity value of 21% written within the pie chart slice for the Miscanthus chips transport distance was calculated by:

- Subtracting the value of the LCOE output from the gPROMS model when the Miscanthus chips transport distance was set to its minimum value (0km) from the value of the LCOE output with it set to its maximum value (800km), with other values held at their base case. The absolute difference in LCOE between min and max Miscanthus chips transport distances was $128 - 51 = 76$ (in units of £/MWh_{th})
- This absolute difference is then divided by the sum of the absolute differences between the LCOE values output at the minimum and maximum for all of the Chain 1 input parameters, which in this instance equals 365 (i.e. repeating the first step for each of the parameters individually, and summing the result). This gives a normalised value of $76 / 365 = 21\%$.

So, when a parameter appears as important on the pie chart, it will likely have a large range between min and max input values, and have an important influence on the model behaviour. Bear in mind that these sensitivities are for the chosen chain architectures, and are run one parameter at a time for the base case, so do not explore the whole of the parameter space (varying multiple parameters at the same time) – but do give a good indication of the simple sensitivities that the model exhibits (and indeed would correspond to global sensitivities if the chain model were linear).

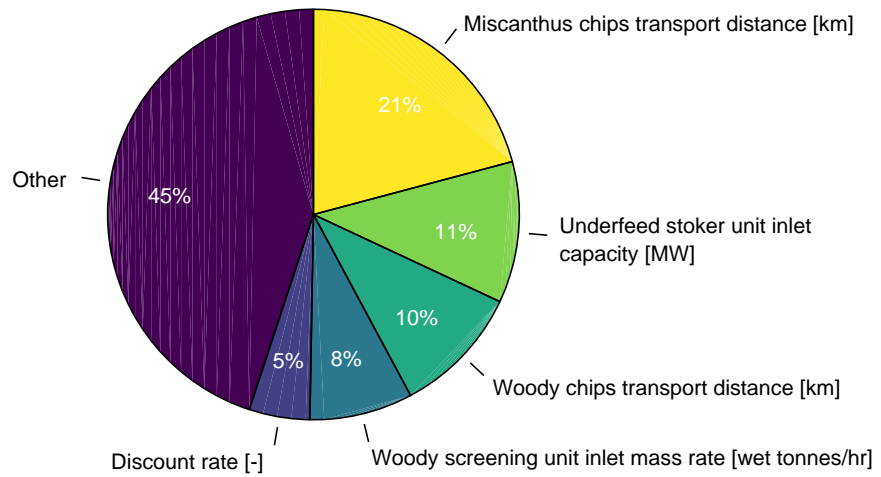

Figure 4.21: Chain 1 LCOE sensitive parameters pie chart

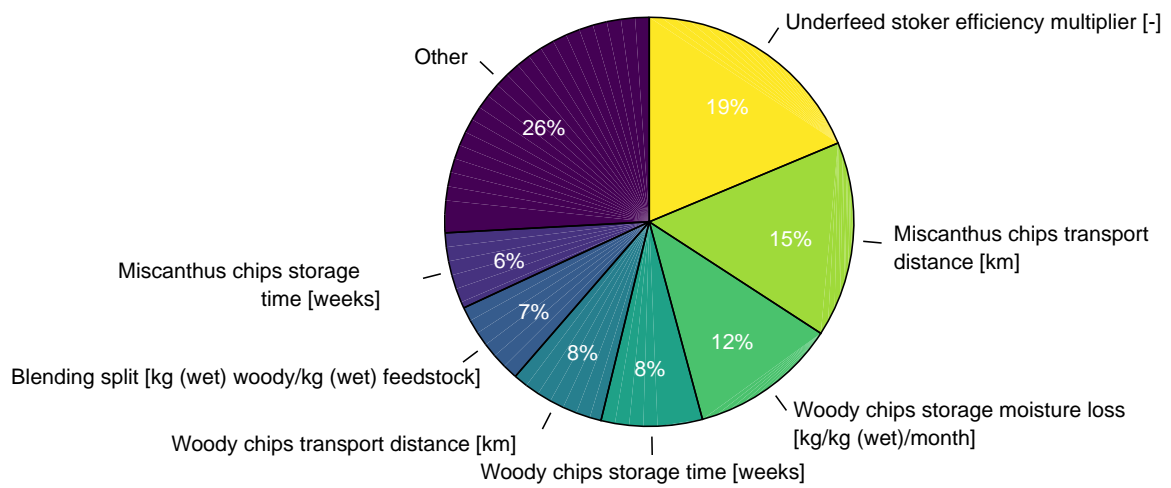

Figure 4.22: Chain 1 net efficiency sensitive parameters pie chart

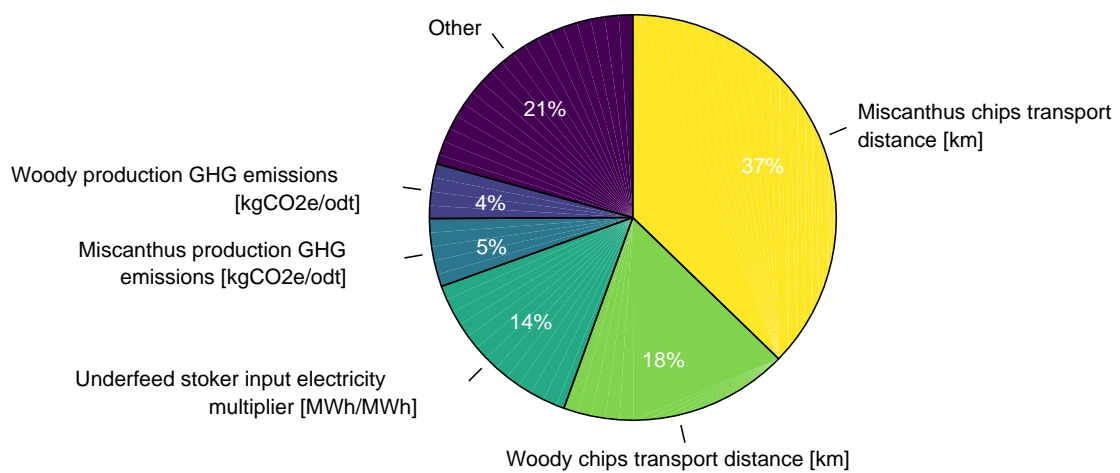

Figure 4.23: Chain 1 GHG emissions sensitive parameters pie chart

These Chain 1 pie charts show that the Miscanthus chip transport distance is the most important parameter for the LCOE and the GHG emissions. This makes sense given that the density of chipped Miscanthus is very low, and the trucks assumed are reasonably small, and hence a very large number of trucks will be needed to transport the Miscanthus chips (at high cost, and with high diesel GHG emissions). The woody chips transport distance is also important, though not as important as the Miscanthus chip transport distance, due to the higher density of woody chips. The boiler capacity and screening mass rates influence the chain LCOE, but do not impact the chain net efficiency or GHG emissions (as the efficiencies of these technologies do not change with scale).

Between them, these two transport distance parameters make up over half of the total variation in the GHG emissions, with the other important parameters relating to the GHG emissions of the starting feedstock, and the power input required by the boiler. In contrast to the other Chain 1 pie charts, the LCOE pie chart has a very large “Others” segment, showing that many parameters have a relatively small effect on the LCOE results.

For the net chain efficiency, the underfeed stoker efficiency multiplier is the most important parameter. However, the net chain efficiency is strongly affected by a number of parameters, mainly relating to storage and transport. The blending split between Miscanthus and woody feedstock also has some impact, due to the differences in contaminant levels, and their differing densities impacting the amount of diesel consumed in transport (which lowers the net chain efficiency).

4.5.2 Chain 2 – Underfeed stoker combustion boiler with screening and field washing

The LCOE sensitivities for Chain 2 are very similar to those for Chain 1, except that the “Other” category is slightly larger, and the key sensitivities have slightly lower normalised %s – which is to be expected based on the addition of the field washing parameters. For example, in Figure 4.21, the Miscanthus chips transport distance parameter makes up 21% of the total variation in Chain 1 LCOE, whereas in Figure 4.24, this same parameter only makes up 19% of the total variation in Chain 2 LCOE – mainly as the total variation in Chain 2 is higher.

For the Chain 2 net efficiency sensitivities, there is also a similar picture to Chain 1, with the boiler efficiency the most important parameter. However, the Woody chips storage moisture loss parameter has risen in relative importance, due to the field washing adding moisture to the biomass, which means that the rate at which the biomass dries out is now more important to Chain 2 (since slower drying rates would mean that the biomass would arrive wetter at the boiler than in Chain 1, significantly reducing its efficiency).

The GHG emissions sensitivities for Chain 2 are similar to those for Chain 1, with transport distances dominating. There is also an additional small sensitivity due to the Woody field wash unit inlet mass rate, which is not present in Chain 1, since larger field washing units will consume proportionally less input electricity per tonne of biomass.

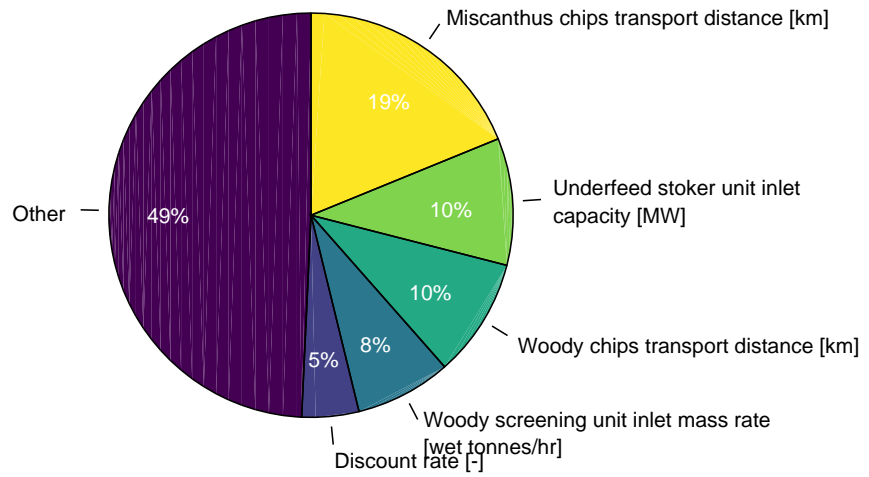

Figure 4.24: Chain 2 LCOE sensitive parameters pie chart

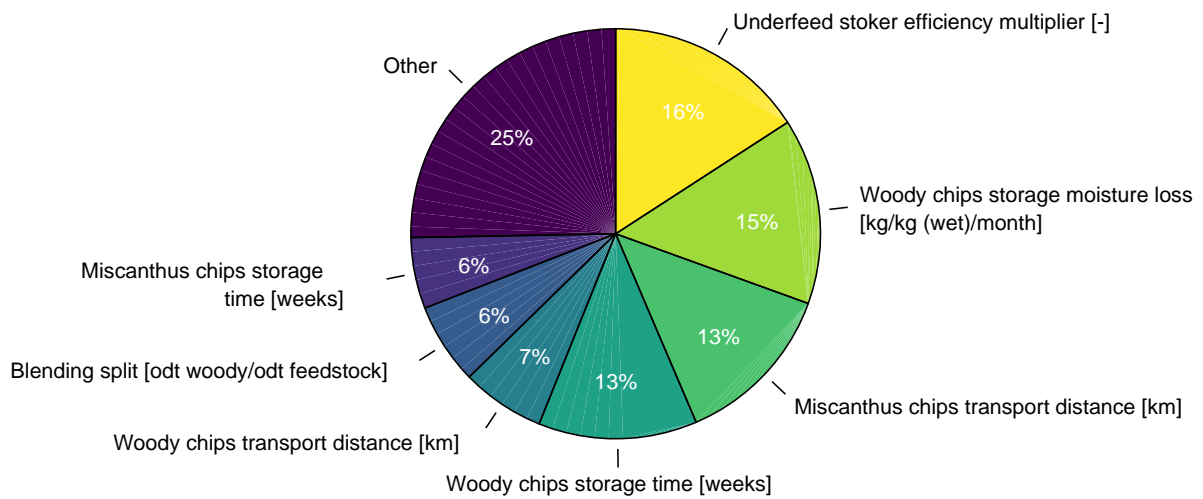

Figure 4.25: Chain 2 net efficiency sensitive parameters pie chart

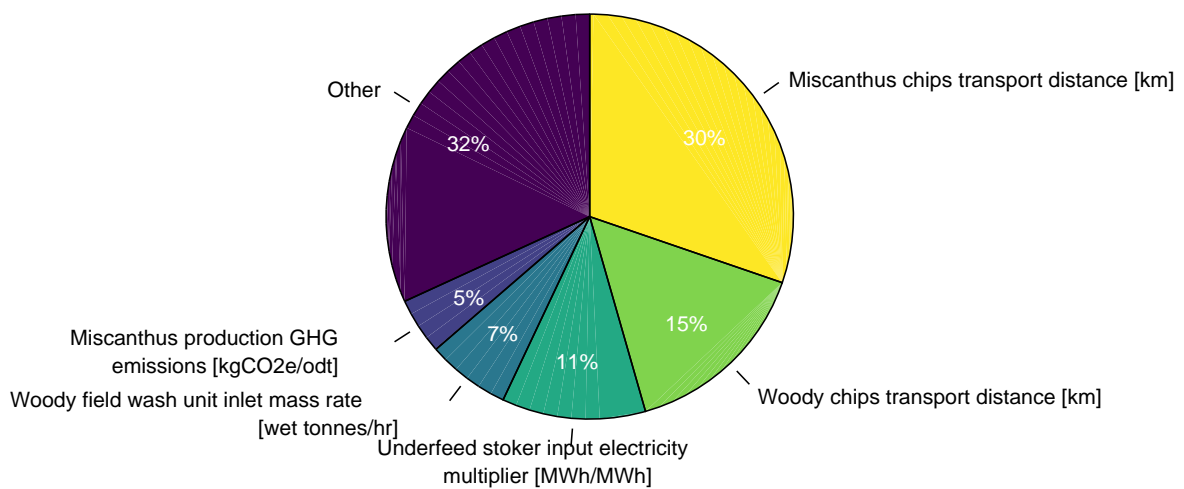

Figure 4.26: Chain 2 GHG emissions sensitive parameters pie chart

4.5.3 Chain 3 – BFB gasifier + syngas engine with screening

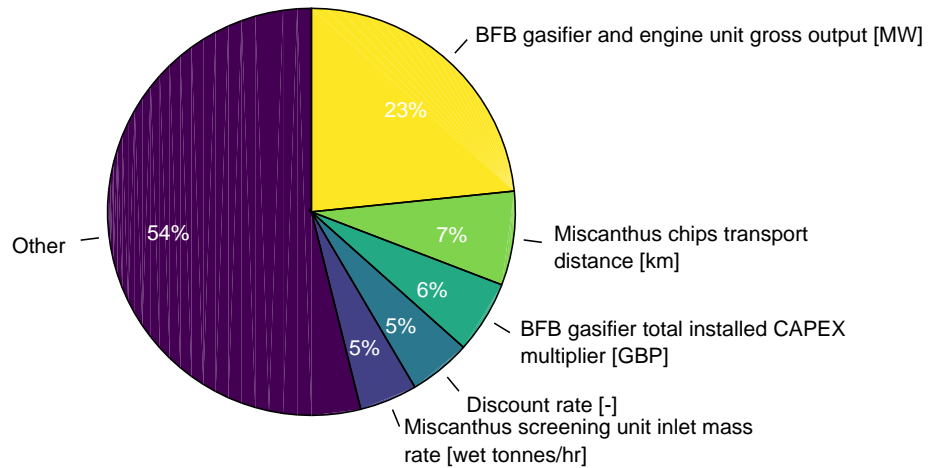

Figure 4.27: Chain 3 LCOE sensitive parameters pie chart

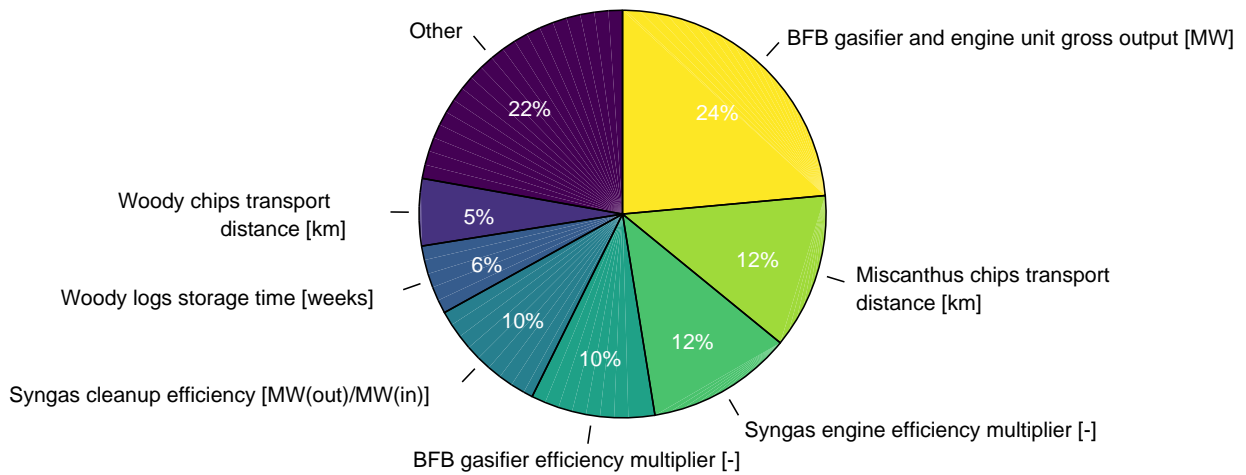

Figure 4.28: Chain 3 net efficiency sensitive parameters pie chart

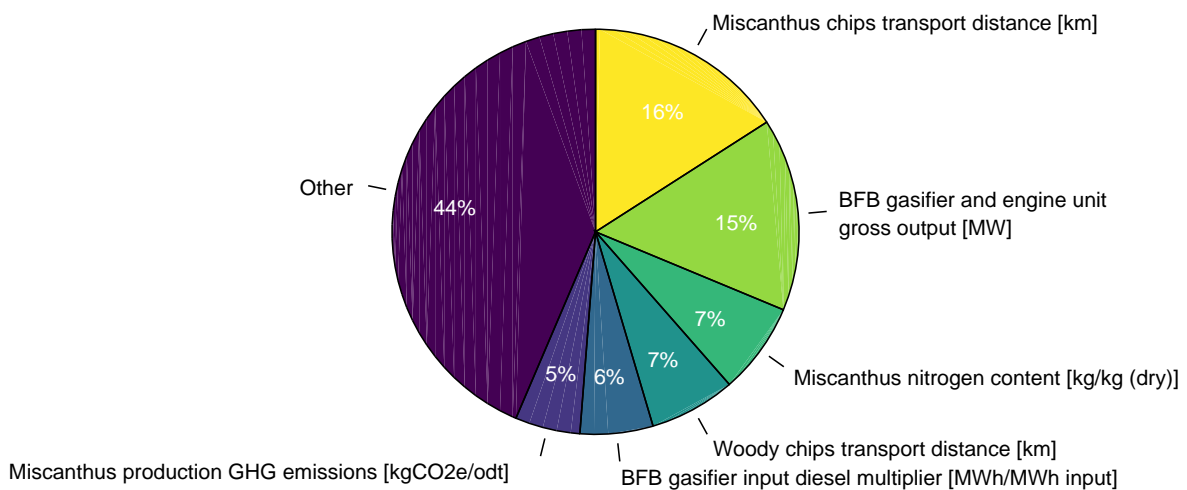

Figure 4.29: Chain 3 GHG emissions sensitive parameters pie chart

These Chain 3 pie charts show that the BFB gasifier + syngas engine unit gross output (i.e. the conversion unit capacity) is the most sensitive parameter for both the LCOE and the net efficiency. This is expected given the high component LCOE of the conversion step, the relationship between conversion unit capacity and CAPEX, and the relationship between syngas engine capacity and its efficiency. The impact of the conversion unit capacity on the conversion efficiency also explains its impact on the chain GHG emissions pie chart (as it impacts the per MWh_e emissions of all the chain components). The high cost of the conversion unit also explains the presence of the BFB gasifier total installed CAPEX multiplier, and the discount rate, on the LCOE sensitivity pie chart.

As in Chains 1-2, Miscanthus chips transport distance is a key sensitivity for GHG emissions, as well as impacting net chain LCOE and efficiency, due to the costs and diesel use in trucking very low density Miscanthus chips. However, the trucks in Chain 3 are larger and more efficient than in Chains 1-2, explaining the smaller relative sensitivities, and the reduced sensitivity of wood chip distance.

Notable in the net chain efficiency pie is the presence of three sub-unit parameters¹⁷ directly determining the BFB gasifier, syngas clean-up and syngas engine efficiencies (these also appear in Chain 4). Combined, these three parameters would actually have a larger impact than the conversion unit capacity, suggesting that opportunities for system integration within the plant will be important. Woody logs storage time appears as a minor sensitivity for the Chain 3 efficiency, as the degradation over 4 years (the maximum storage time assumed) can be relatively significant.

The Miscanthus nitrogen content is important to the GHG emissions in Chain 3, as unlike in Chains 1-2, urea is used to treat the conversion plant NO_x arising from the biomass nitrogen content¹⁸, and urea has a high GHG emissions factor. The diesel used in BFB gasifier start-ups also has an impact.

4.5.4 Chain 4 – BFB gasifier + syngas engine with water washing and pelleting

Compared to Chain 3, BFB gasifier + syngas engine unit gross output (i.e. the conversion unit capacity) is now the most sensitive parameter for all three pie charts, followed by the Miscanthus bales transport distance. This is for taking bales to the centralised pre-processing plant, not for chip transport direct to the BFB gasifier (as in Chain 3). Although Miscanthus bales have a slightly higher density than Miscanthus chips, and the maximum distances are equal, Chain 4 is using much smaller trucks for this new initial transport step compared to the large, efficient flatbed trucks in Chain 3. This explains the relatively higher importance of the Miscanthus bales transport distance in Chain 4.

The initial Woody logs transport distance (which uses a similar small forestry truck) appears in all three pie charts, however logs are much denser than bales, hence the sensitivity is lower. The pellet transport distance only appears as a minor sensitivity for the chain efficiency and GHG emissions, as this final transport step is using large, highly efficient walking floor trucks.

The addition of more parameters in Chain 4 has pushed the relative contribution of the Miscanthus nitrogen content to the GHG emissions pie chart below the threshold for contributions shown – this is not due to water washing removing any nitrogen, as the urea is still used.

¹⁷ The BFB gasifier efficiency multiplier and the syngas engine efficiency multiplier are used in gPROMS formulae to calculate the BFB gasifier and syngas engine efficiencies. There is no gPROMS formula for the syngas cleanup efficiency – this is set by the parameter value.

¹⁸ The economic scales for all the power generation plants in TEABPP would have an Emissions Limit Value (ELV) that would likely need NO_x mitigation (particularly with increasing emission constraints in the UK), so a generic formula was used to convert feedstock nitrogen content into a urea consumption to provide for this NO_x mitigation, as set out in the D3 report. Different technologies will have different conversion rates of feedstock nitrogen to NO_x, but if the feedstock nitrogen content is low enough, it is also assumed that the SNCR equipment can be removed, saving on capex and opex, and no longer requiring any use of urea.

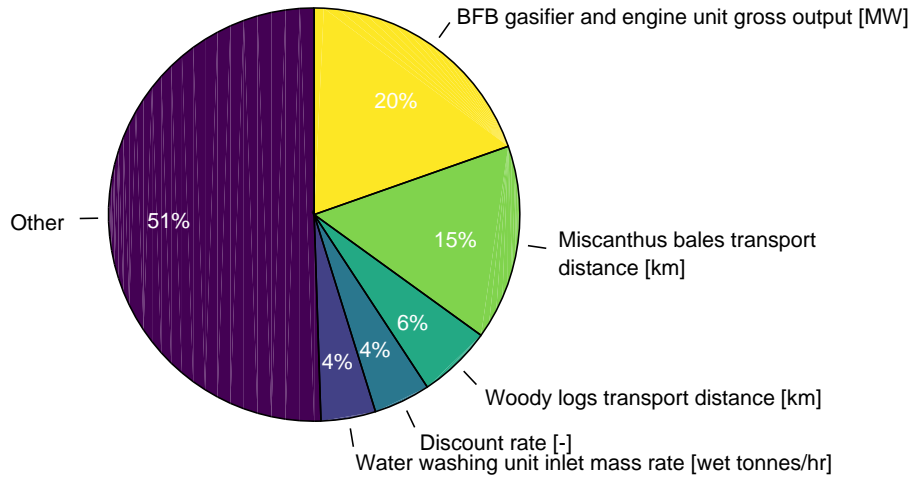

Figure 4.30: Chain 4 LCOE sensitive parameters pie chart

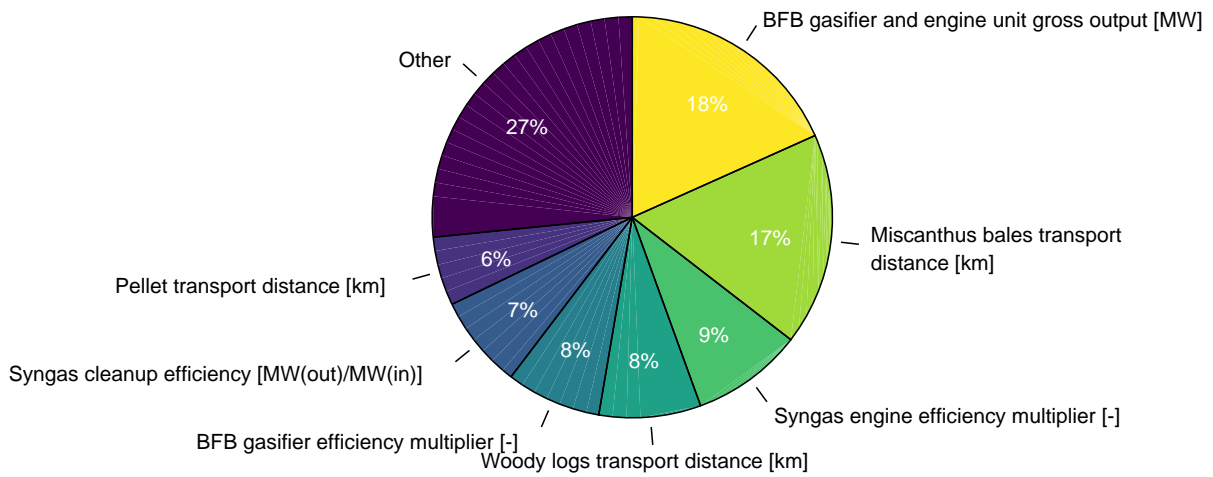

Figure 4.31: Chain 4 net efficiency sensitive parameters pie chart

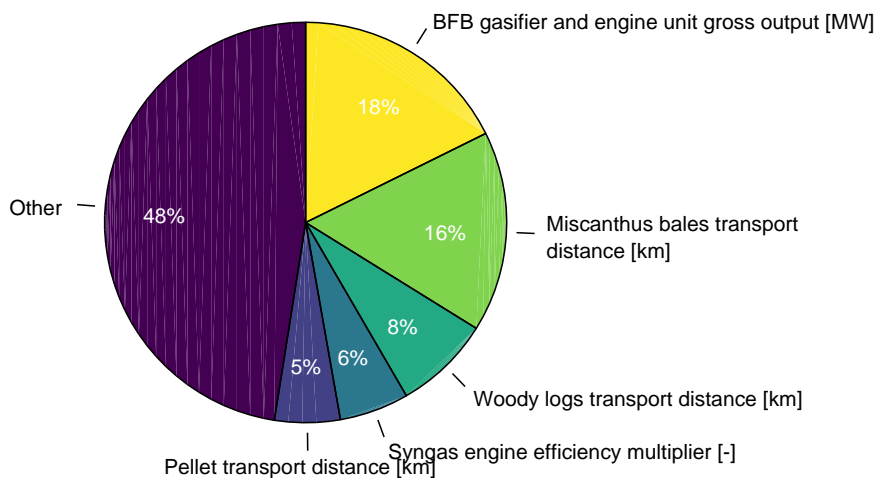

Figure 4.32: Chain 4 GHG emissions sensitive parameters pie chart

4.5.5 Chain 5 – CFB combustion boiler with screening

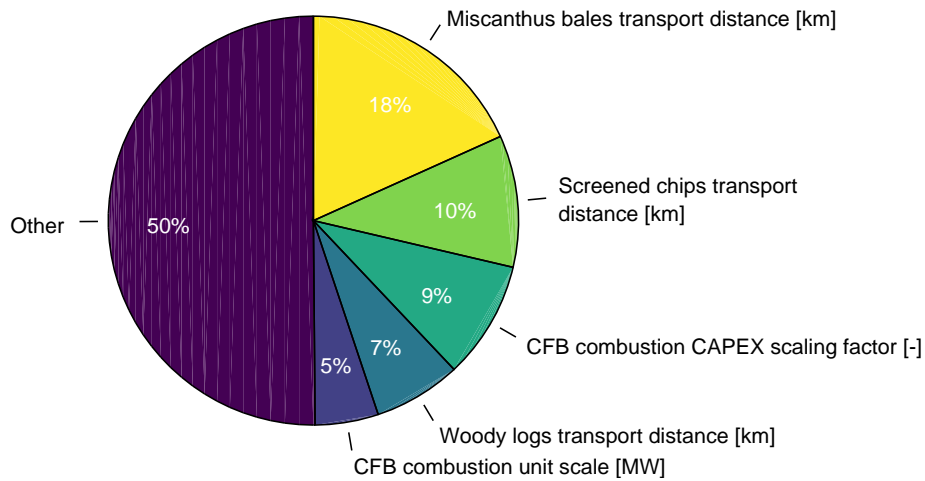

Figure 4.33: Chain 5 LCOE sensitive parameters pie chart

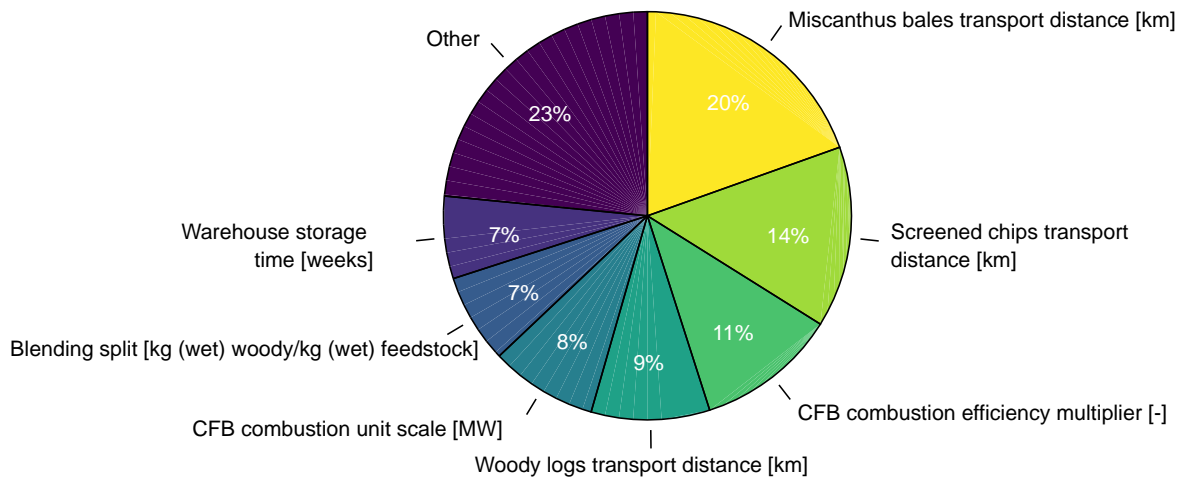

Figure 4.34: Chain 5 net efficiency sensitive parameters pie chart

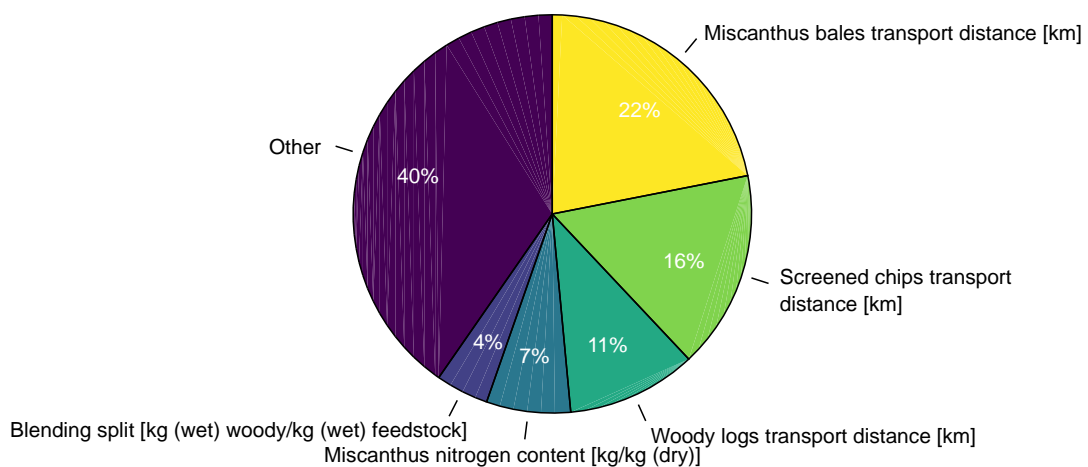

Figure 4.35: Chain 5 GHG emissions sensitive parameters pie chart

The transport distances of both raw feedstocks and of the blended screened chips are very important for all three major metrics in Chain 5, accounting for 35-49% of the total variation. The prominence of Miscanthus bales and screened chip distances are due to their low density, whereas woody logs have a much higher density. These sensitivities are also driven by the 0-800km min-max range chosen – smaller ranges would result in accordingly smaller sensitivities.

The other prominent parameters that impact the Chain 5 LCOE pie chart relate to the scale of the CFB combustion unit, and its CAPEX scaling factor – which is explained by the relative importance of the CFB costs to the overall chain LCOE, and the scaling relationship between CFB combustion unit size and the total installed CAPEX. The CFB combustion unit scale¹⁹ also influences the efficiency of the CFB combustion plant, which explains the presence of the CFB scale and the efficiency multiplier on the efficiency pie chart.

Warehouse storage time appears as a minor sensitivity on the Chain 5 efficiency pie chart, as the degradation of high surface area chips over 2 years (the max storage time assumed) can be relatively significant. The blending split between Miscanthus and woody feedstock also has some impact, due to differences in contaminant levels, and their differing densities impacting the amount of diesel consumed (and so the net chain efficiency).

Similar to Chain 3, the Miscanthus nitrogen content results in a corresponding urea use to mitigate conversion plant NOx emissions, and so appears on the GHG emissions pie.

4.5.6 Chain 6 – CFB combustion boiler with pelleting

The sensitivities for Chain 6 are similar to those for Chain 5, with the main exception that throughout all three pie charts, the Screened chips transport distance is no longer present (as this does not occur in the Chain 6 architecture), and has been replaced by a much less sensitive Pellet transport distance for Chain 6. This lower sensitivity is mainly due to the high density of pellets compared to chips, as well as the quicker-to-unload walking floor trucks in Chain 6, compared to the flatbed trucks in Chain 5.

The CFB combustion CAPEX scaling factor and efficiency multiplier still impact the plant CAPEX and efficiency respectively, and the CFB combustion unit scale still impacts both. The expense of building storage silos means that at the maximum storage time, silo costs are significant enough to account for 8% of the total LCOE variation. Warehouse storage is not used in Chain 6, so no longer appears in these pie charts, with Woody logs storage time appearing instead in the efficiency pie chart, due to degradation over a maximum of 4 years.

There have been no shifts in biomass characteristics with pelleting instead of screening, so no new elemental parameters have appeared. Miscanthus nitrogen content remains on the GHG emissions pie chart due to the urea use. Although Miscanthus and SRF deciduous feedstocks have similar base case Nitrogen contents, Phyllis2 data gives a wider min-max range for Miscanthus (up to 1.8%) than for the Generic woody feedstock (up to 1.2%), and it is these maximum values and their influence on the model that determine the parameter sensitivities.

¹⁹ As mentioned at the start of Section 4.5, every single one of the parameters plotted on the pie charts is an independent input, the value of which does not rely on any of the other parameters plotted. For example, there is no dependency between the CFB scale and the feedstock transport distance – see footnote 21 for further discussion of this ETI choice. CFB combustion plant efficiency is an intermediate parameter calculated within TEABPP, and is not an independent input parameter (unlike the CFB combustion plant efficiency multiplier, or the Miscanthus chlorine content, which are both independent input parameters that impact the CFB combustion plant efficiency).

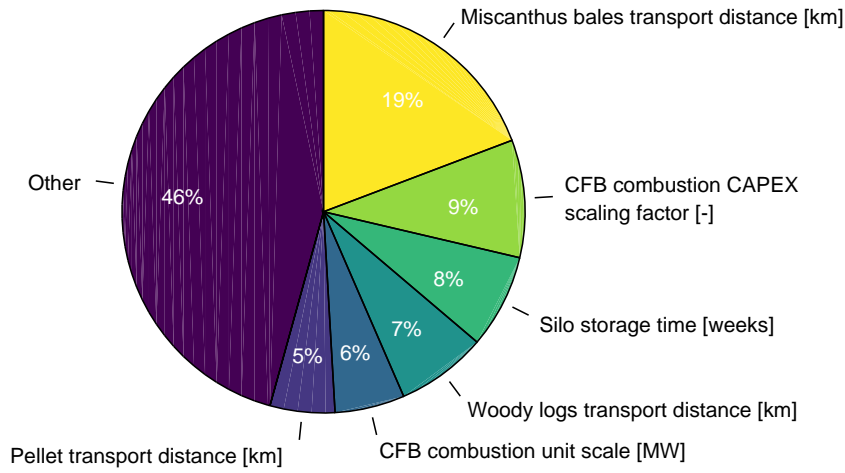

Figure 4.36: Chain 6 LCOE sensitive parameters pie chart

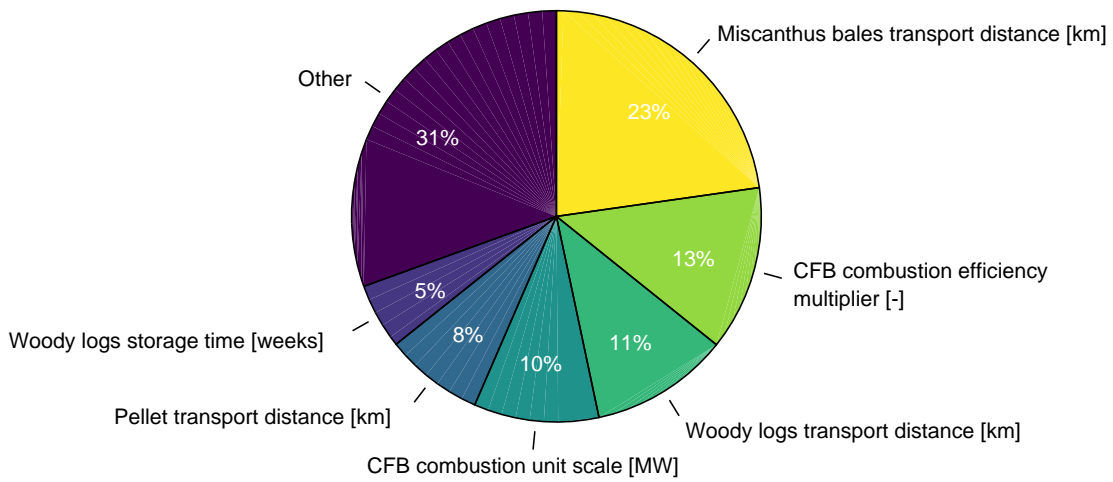

Figure 4.37: Chain 6 net efficiency sensitive parameters pie chart

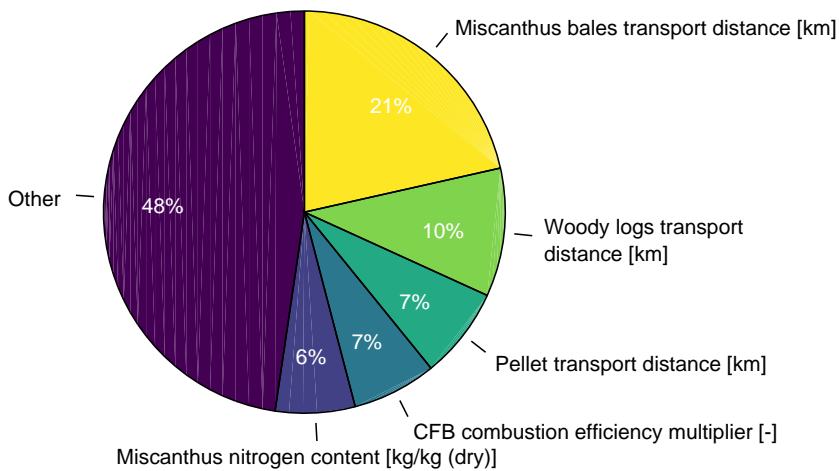

Figure 4.38: Chain 6 GHG emissions sensitive parameters pie chart

4.5.7 Chain 7 – CFB combustion boiler with chemical washing and pelleting

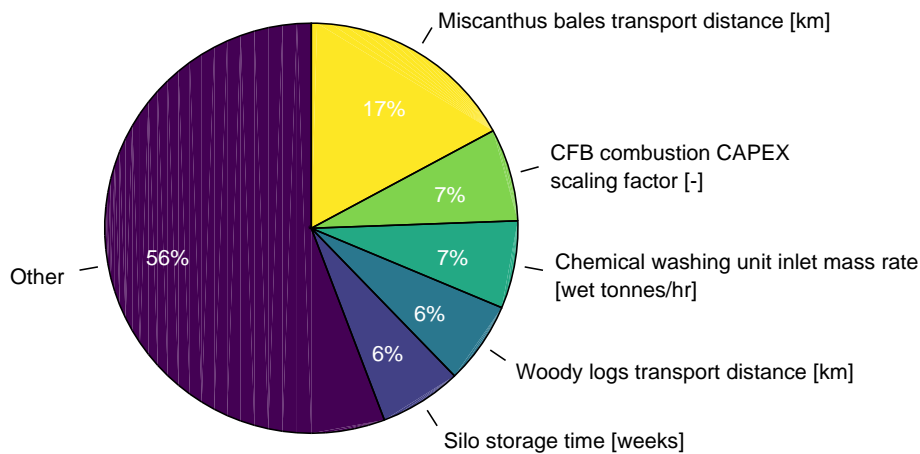

Figure 4.39: Chain 7 LCOE sensitive parameters pie chart

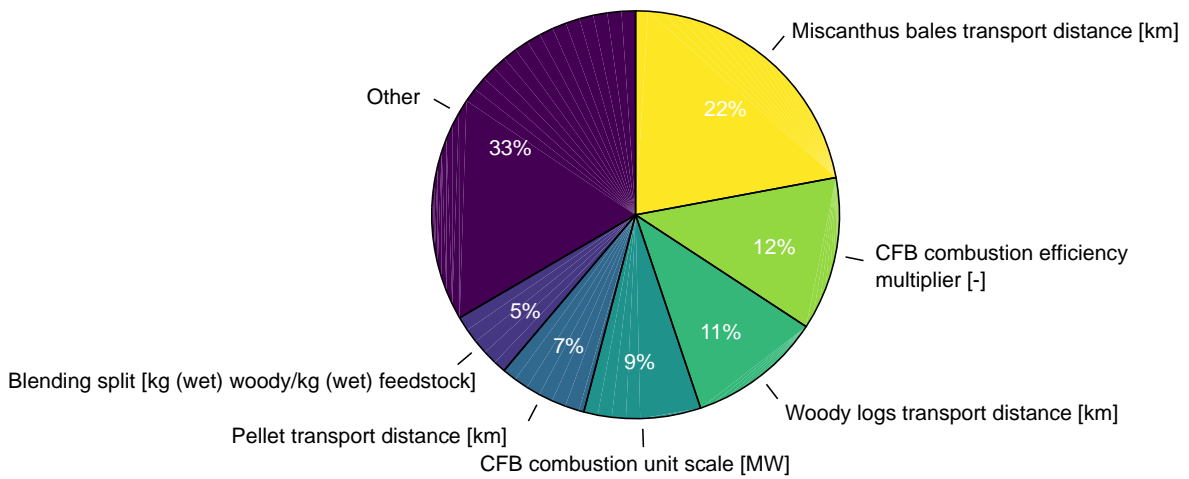

Figure 4.40: Chain 7 net efficiency sensitive parameters pie chart

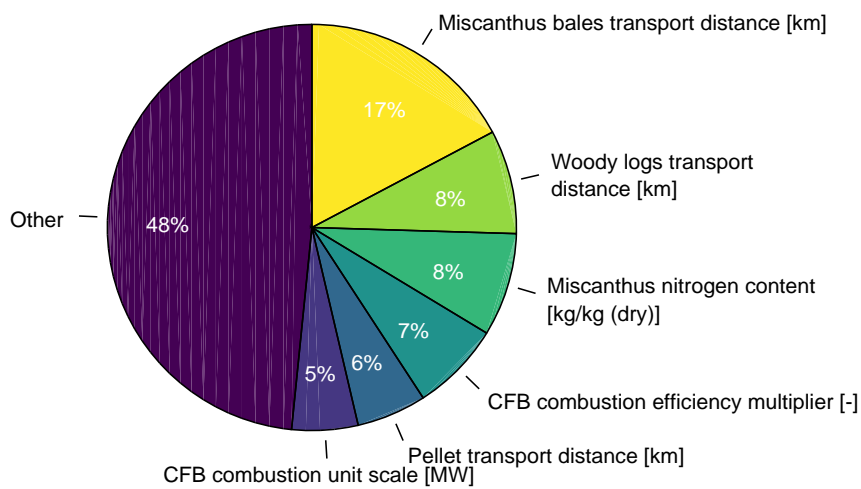

Figure 4.41: Chain 7 GHG emissions sensitive parameters pie chart

The sensitivity pie charts for Chain 7 share many similarities with Chain 6. In particular, the net chain efficiency pie charts are almost identical, with the only explicit difference being the last/least important parameter shown before the cut-off (blending split instead of woody logs storage time). The similarities are explained by the fact that the additional chemical washing step in Chain 7 does little to impact the chain efficiency (minor losses balanced by some efficiency benefits for the CFB combustion plant).

However, the scale²⁰ of the chemical washing unit does have a relatively strong influence on the LCOE, given the scaling relationship between the chemical washing unit scale and CAPEX, and the large costs added by chemical washing. Those “Other” parameters that individually contribute less than 5% to the LCOE variation together contribute to more than 50% of the LCOE variation – this is partly to do with the very large number of parameters and complexity present in Chain 7.

The Miscanthus nitrogen content has a greater relative effect on the GHG emissions pie chart than in Chain 6, because the chemical washing step will increase the biomass nitrogen content, requiring more urea to be consumed in the CFB combustion plant – and hence Chain 7 is more sensitive to the Miscanthus and Woody nitrogen contents (the Woody nitrogen contribution is just under 5%, so not explicitly shown).

4.5.8 Chain 8 – EF gasifier + syngas CCGT with pelleting

The Chain 8 pie charts show that the EF gasifier + CCGT unit gross output (i.e. the conversion unit capacity) and the Miscanthus bales transport distance are the two most sensitive parameters across all three metrics.

This makes sense given the high LCOE component cost of the conversion unit, the scaling relationship between conversion unit capacity and CAPEX, and the relationship between the size of the syngas CCGT and its efficiency. The impact of the conversion unit capacity on the conversion efficiency also explains its impact on the chain GHG emissions pie chart. As in Chain 6, the transport distance for the Miscanthus bales is more important than for the Woody logs, which is more important than the pellet transport distance, due to the ordering of the densities and truck sizes.

The expense of building storage silos means that at the maximum storage time, silo costs are significant enough to account for 7% of the total LCOE variation. Like Chain 7, the LCOE for Chain 8 has the majority of its variation explained by less sensitive parameters.

The efficiency multipliers for the individual conversion sub-units (EF gasifier, syngas clean-up and CCGT) contribute roughly evenly to the net chain efficiency and also the GHG emissions. There are no biomass element parameters explicitly shown on any of the pie charts, so whilst the conversion unit still uses urea, the Miscanthus and Woody nitrogen contents now contribute <5% to the chain GHG emissions.

²⁰ Note that in any chain, the scale of the pre-processing unit is an independent user-defined variable in the gPROMS model (with a base case value and min-max range), and is not calculated based on the scale of the conversion plant, which is a separate user-defined variable in the gPROMS model (with its own base case and min-max range). For reference, the scales of the chemical washing unit and CFB combustion plant are listed in the separate Excel workbook “Inputs ranges with innovation”.

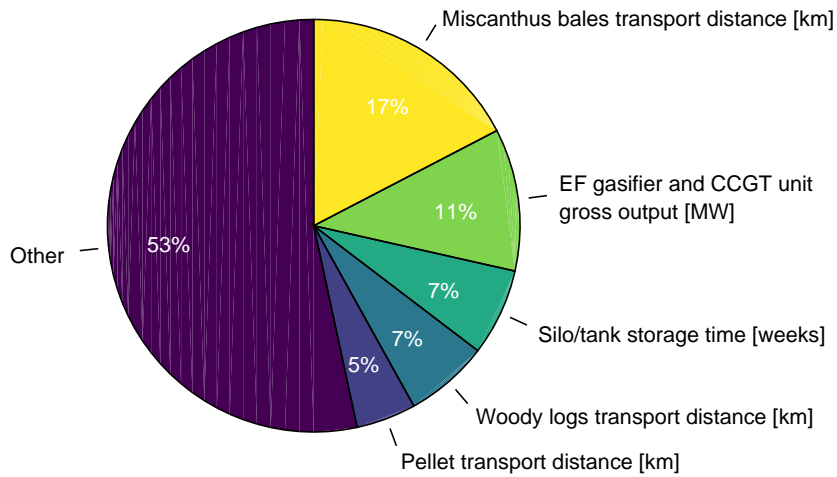

Figure 4.42: Chain 8 LCOE sensitive parameters pie chart

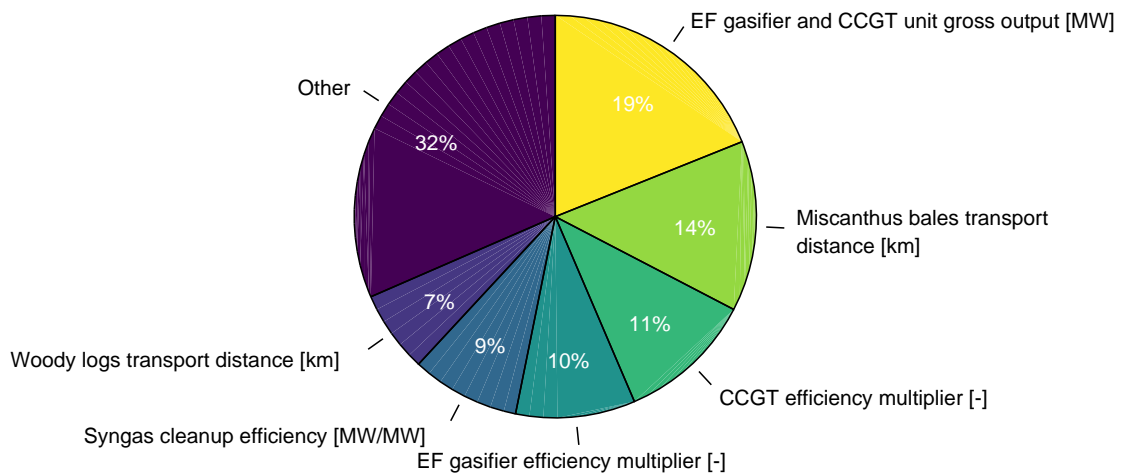

Figure 4.43: Chain 8 net efficiency sensitive parameters pie chart

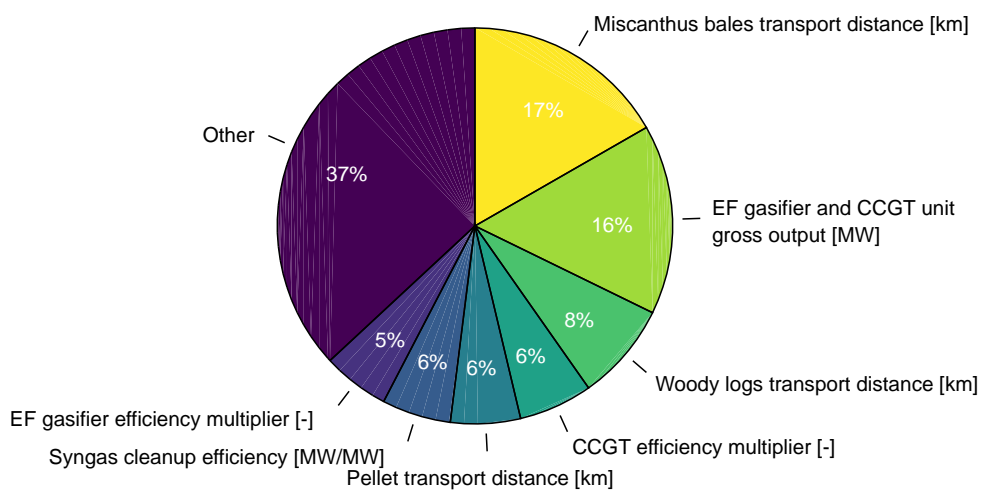

Figure 4.44: Chain 8 GHG emissions sensitive parameters pie chart

4.5.9 Chain 9 – EF gasifier + syngas CCGT with torrefaction + pelleting

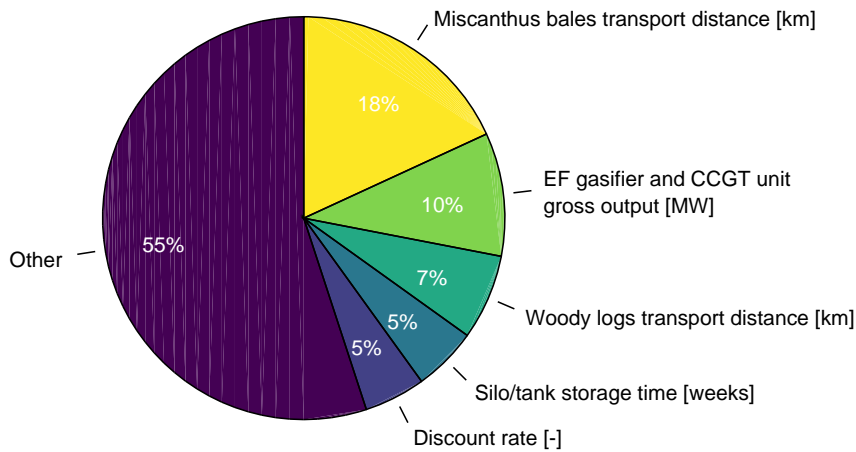

Figure 4.45: Chain 9 LCOE sensitive parameters pie chart

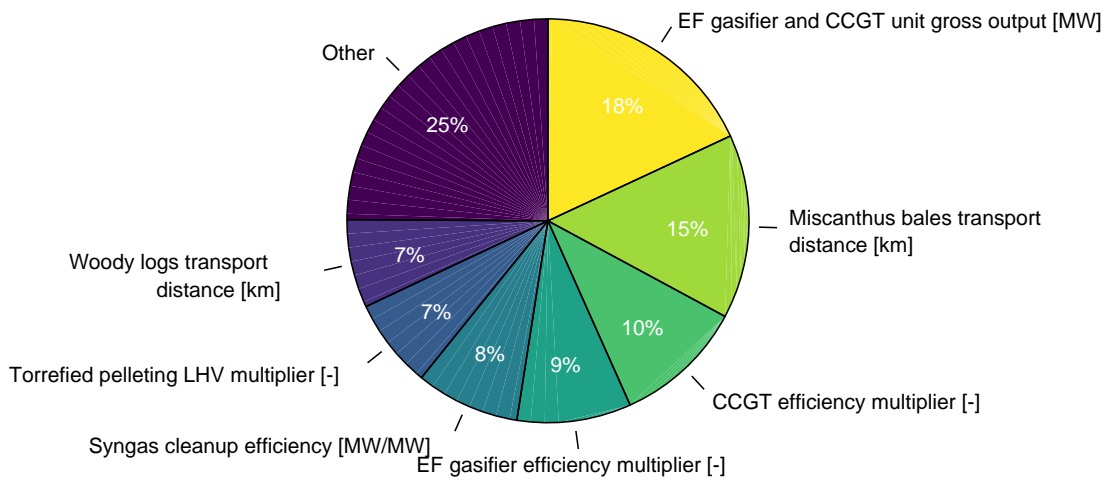

Figure 4.46: Chain 9 net efficiency sensitive parameters pie chart

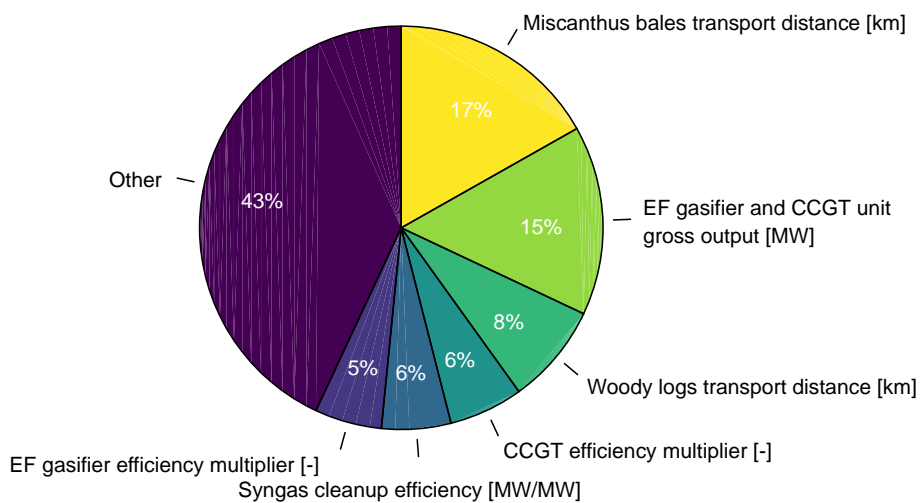

Figure 4.47: Chain 9 GHG emissions sensitive parameters pie chart

The sensitivity pie charts for Chain 9 are very similar to those of Chain 8.

The only differences in the LCOE pie chart are a slightly lower sensitivity for the silo storage time, which is due to the higher energy density of the torrefied pellets requiring less silo volume and so less CAPEX, plus the disappearance of the pellet transport distance below the 5% cut-off, which will be due to the higher energy density of the torrefied pellets making Chain 9 less sensitive to the pellet transport distance than Chain 8.

The Chain 9 efficiency pie chart is very similar to Chain 8, but now also includes the Torrefied pelleting LHV multiplier as a minor sensitivity, which makes sense as a higher energy density pellet translates into less diesel use in trucking. The efficiency of the torrefaction+pelleting step itself does not appear, as this is defined by the input and output biomass moisture and LHVs (the mass and energy balance of the pre-processing plant), and does not have a multiplier parameter. The EF gasifier parasitic power required for grinding torrefied pellets is very low, and so will not appear explicitly as a key sensitivity.

The GHG emissions pie chart for Chain 9 is relatively similar to Chain 8. The most sensitive parameters are still the Miscanthus bales and woody logs transport distances plus EF gasifier + CCGT unit gross output, and the efficiency multipliers for the individual conversion sub-units (EF gasifier, syngas clean-up and CCGT) are still present. The pellet transport distance does not appear above the 5% cut-off, as torrefied pellets have a higher energy density than standard pellets, and therefore Chain 9 uses a lower amount of diesel in trucking than Chain 8, reducing the relative sensitivity of the Chain 9 GHG emissions results to the final pellet transport distance compared to Chain 8. The GHG emissions of Chain 9 are only slightly higher than those in Chain 8, so the sensitivity of Chain 9 to torrefaction parameters such as the torrefaction+pelleting plant availability, output pellet LHV and fire suppressant use are below the pie chart thresholds.

4.5.10 Chain 10 – EF gasifier + syngas CCGT with pyrolysis

For the LCOE and GHG emission sensitivity pie charts, the Miscanthus bales transport distance remains the most sensitive parameter. However, in contrast to Chains 8 and 9, the Miscanthus inherent ash content is now the most important parameter for chain efficiency, and second most important for LCOE and GHG emissions. This is due to the very strong inverse relationship between feedstock ash content and the pyrolysis plant efficiency, and since Miscanthus has a wider range of min-max inherent ash content than the generic Woody feedstock. The Woody inherent ash content parameter does appear on the efficiency pie chart as being responsible for 8% of the total variation.

The relative LCOE sensitivity of the conversion unit capacity is also slightly reduced, as the CAPEX of the conversion unit is reduced in Chain 10 (due to removal of solids handling and grinding sections by using pyrolysis oil). However, the pyrolysis unit scale also impacts the chain LCOE, as the minimum scale pyrolysis plants will have very high levelised CAPEX, and the pre-processing component already added significant costs to the chain.

The conversion unit capacity (which changes the CCGT efficiency) and the pyrolysis efficiency multiplier are both strong contributors to the variation in the net chain efficiency, and also impact the GHG emissions. Transport distances for the raw feedstocks appear explicitly on the pie charts, but not the transport distance for the pyrolysis oil, as this is at a high densities in a large tanker.

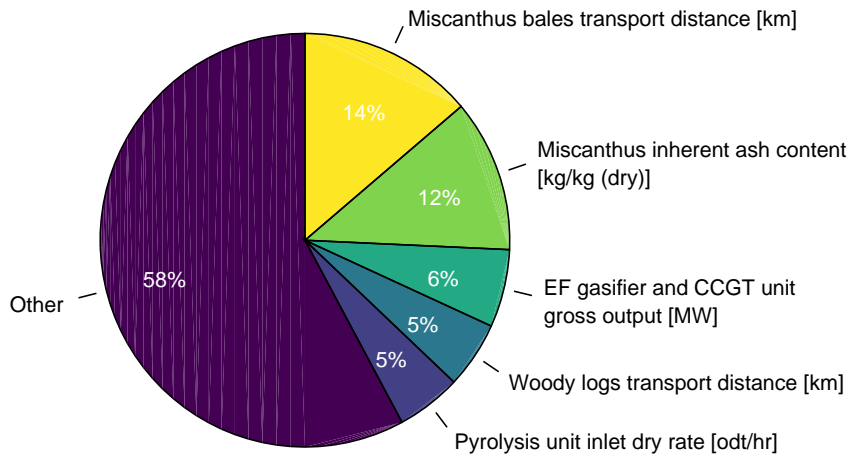

Figure 4.48: Chain 10 LCOE sensitive parameters pie chart

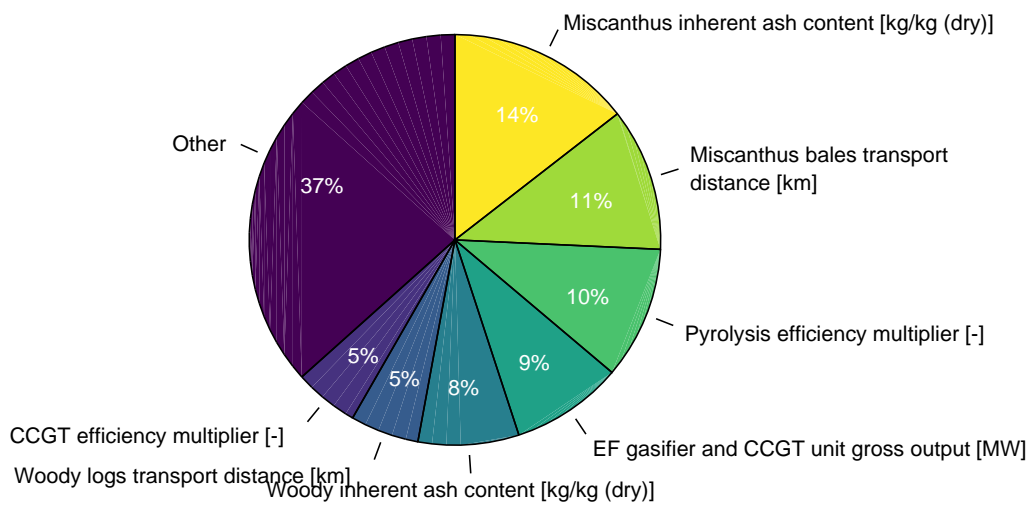

Figure 4.49: Chain 10 net efficiency sensitive parameters pie chart

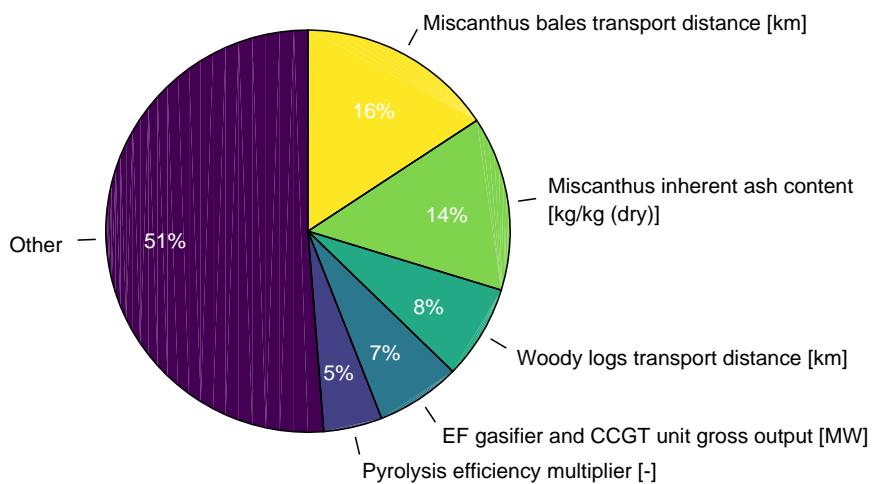

Figure 4.50: Chain 10 GHG emissions sensitive parameters pie chart

4.6 Spider chart sensitivities

Using the automated link between gPROMS and MoDS, CMCL have run the gPROMS model using 20 different values for each parameter. This process goes from the minimum of the parameter values, through the base case, and ending up at the maximum of the parameter values, whilst holding the rest of the values at their base case.

The net chain LCOE, efficiency and GHG emissions have been recorded at each input point, with the MoDS interface then gathering the collected information to allow CMCL to plot the three key output metric spider charts for each chain. These spider charts only plot a limited number of the most sensitive parameters, for ease of viewing – these are the same parameters that were explicitly shown as being sensitive in the pie charts in the previous section (so using the same 5% cut-off or top 5 approach).

Spider charts show the variation in an output metric as a number of input parameter series are independently varied. Note that every single one of the parameters plotted on the spider charts is an independent input, the value of which does not rely on any of the other parameters plotted.

The base value is always plotted at 0 on the x-axis, to make all diagrams converge/cross at the default base value, and the min and max values are normalised along the x-axis relative to the base case value.

The values on the x-axis in the spider charts have been computed as $x' = (x - x_{\text{base}}) / (x_{\text{max}} - x_{\text{min}})$, in order to be able to show those parameters that have a base case = 0. This means if the base case is at the minimum of the input range, then the line on the spider chart for that parameter will extend from 0 to +1 on the x-axis. And vice versa, if the base case is at the maximum of the input range, then the line on the spider chart for that parameter will extend from -1 to 0 on the x-axis. The normalised x-axis input range approach therefore shows where the base case value lies in relation to the min and max values for each input parameter, based on how far left or right the lines extend from the base case. As a reminder, the underlying absolute values of the base case, minimum and maximum for each parameter can be found in the separately provided Excel workbook.

On the spider diagram, the gradient of each line at a given point represents the local sensitivity to changes in the particular input parameter at that point. The steeper the gradient, the more sensitive the input parameter is, and the more important that parameter is to the overall chain (critical impact) – and vice versa, the flatter the line, the less sensitive the input parameter is, and the less important that parameter is to the overall chain (minimal impact). The sign of the gradient also gives the direction of the influence (e.g. negative or positive LCOE impact by increasing the input parameter).

The curvature of the lines in different regions also gives valuable information as to regions in which each input parameter becomes more or less sensitive (e.g. due to non-linear or discontinuous functions, of which there are many in gPROMS). A straight line would indicate that the local sensitivities around the base case apply across the parameter space, whereas highly curved lines or lines with steps indicate more complex underlying behaviour, and different local sensitivities depending on the region of the parameter space.

4.6.1 Chain 1 – Underfeed stoker combustion boiler with screening

As an explanation of how to read the first spider diagram (Figure 4.51), take for example the discount rate green line. Since we can observe that the discount rate line runs between -0.5 and +0.5 on the x-axis, we know that its input minimum and maximum values are equally distributed from its input base case value. This is correct, as the base case discount rate = 10%, with a min-max range of 5-15%. By looking at the left-hand end of the green line, we can read the LCOE value that is achieved at the minimum discount rate, and vice versa with the right-hand end. As this green line is relatively flat, we know that the Chain 1 LCOE is not very strongly dependent on the discount rate parameter. And given the slope is up to the right (gradient is positive), this means that a higher discount rate leads to higher Chain 1 LCOE.

Taking another example in the same chart, the Miscanthus chips transport distance parameter (blue line) goes from just below 0 to almost 1, reflecting that its input base case value (20km) is close to its minimum value (0km), and far from its maximum (800km). This blue line is much steeper, reflecting the fact that the Chain 1 LCOE is strongly dependent on this parameter. The line is also very straight, showing that the LCOE is linearly dependent on the Miscanthus chips transport distance.

In contrast, the underfeed stoker unit inlet capacity (red line) and woody screening unit inlet mass rate (purple line) have a non-linear relationship with LCOE. The screening mass rate causes the LCOE to increase rapidly as it approaches its minimum value (0.7 wet tonnes/hr), since very small plants have very high levelised CAPEX values.

Note that, for example, the underfeed stoker unit inlet capacity and the Miscanthus chips transport distance are not directly correlated or linked – both parameters are independent inputs, and the transport distance does not depend on the scale of the conversion technology²¹.

²¹ This is an assumption made in TEABPP, given ETI wished to have user control of the conversion technology scale and of the transport distances. In reality, larger plants might on average source their biomass from further afield, but as TEAPP is not geographically specific, there is no formulae implemented that attempts to calculate the average collection radius for different scale facilities given local biomass yields and road tortuosity etc. However, the base case values for the final transport distances in Chains 1 - 2 are only 20km (for an underfeed boiler base case of 0.44 MW_{th}), in Chains 3 - 4 are 50km (for a BFB gasifier+syngas engine base case of 4.7 MW_e), and in Chains 5 - 10 are 150km (for base cases of 100MW_e for CFB combustion and 270MW_e for EF gasifier+CCGT), so the larger base case conversion plant scales are reflected in the choice of larger base case transport distances for the analysis. The full list of independent input parameters, and their base cases and min-max values, for each chain are given in the separate Excel workbook "Inputs ranges with innovation".

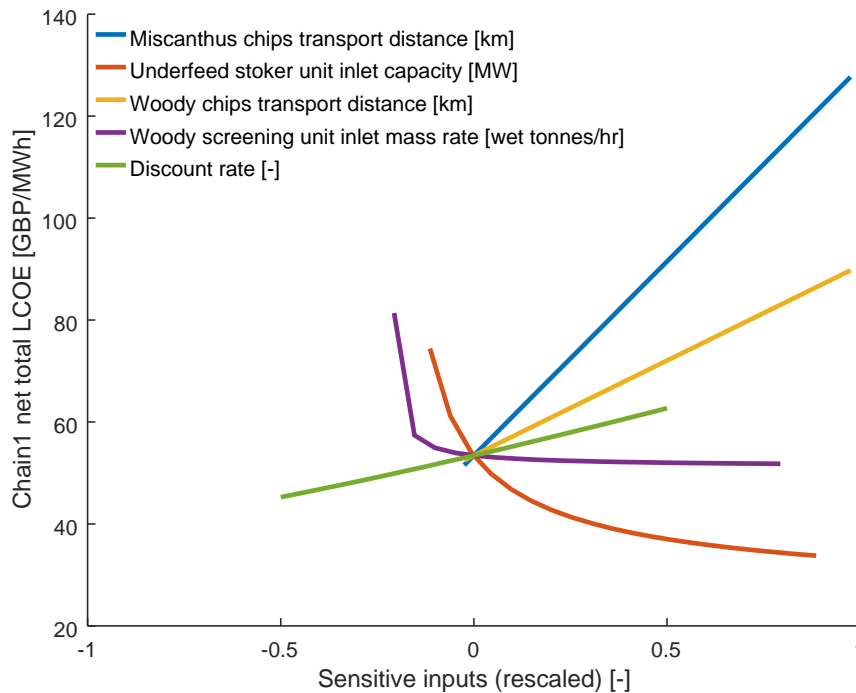

Figure 4.51: Chain 1 LCOE sensitive parameters spider chart

Decreasing the discount rate and increasing either the underfeed stoker boiler or woody screening capacities reduces the Chain 1 LCOE, with the largest improvement in LCOE to be made from scaling up the underfeed stoker boiler capacity²². Very small screening units (below ~5 wet tonnes/hr) likely have to be avoided due to their high costs, but much larger screening units provide relatively little benefit over the base case of 15 wet tonnes/hr. The LCOE results are highly sensitive to the chip transport distances, so these should be kept low – however, the gains to be made from reducing these distances below their base case values (of 20km) are limited, as there is very little difference in chain LCOE between 0-20km.

²² Note that a larger underfeed stoker boiler will have lower levelised CAPEX and OPEX, but is not assumed to have higher efficiency.

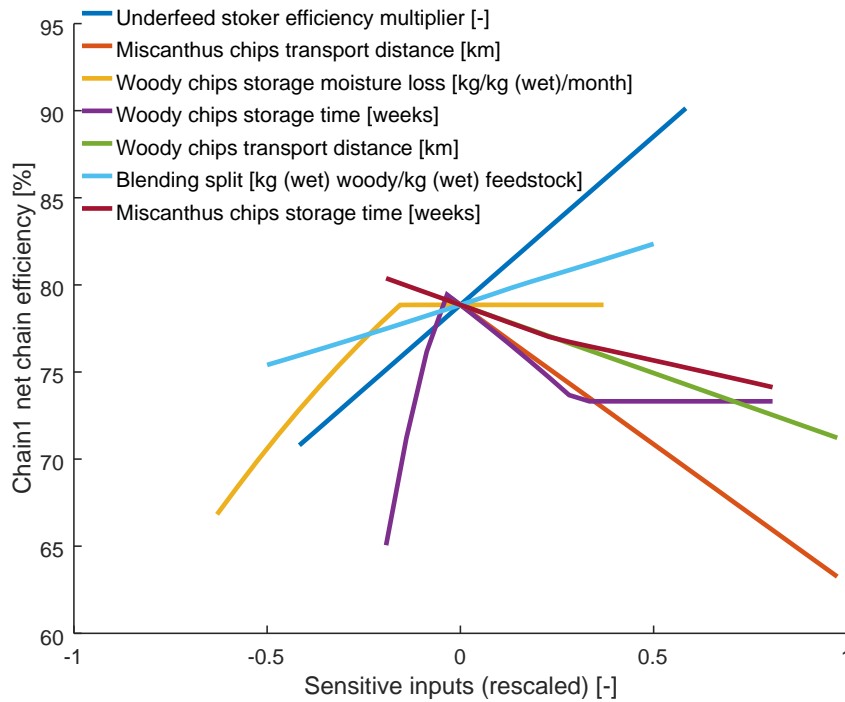

Figure 4.52: Chain 1 net efficiency sensitive parameters spider chart

It is clear that for Chain 1, the underfeed stoker efficiency multiplier is the most important parameter for increasing the net chain efficiency. Increasing the fraction of woody feedstocks (thereby decreasing the usage of Miscanthus) also leads to higher efficiencies, due to the impact of the Miscanthus chemical properties on boiler performance. A shorter storage time for Miscanthus chips would also slightly improve the chain efficiency, due to less degradation. All three of these parameters have fairly linear effects.

The rest of the parameters plotted will typically reduce the net chain efficiency if changes are made from the base case, particularly with increases in the chip transport distance.

The two parameters relating to the woody chips storage, the moisture loss rate and storage time, show non-linear behaviour. The moisture loss line (in yellow) shows that above a certain input value, which is just below the base case value, the feedstock reaches the equilibrium moisture content within the base storage time, and the chain efficiency is unchanged from the base case. But if the moisture loss rate is low, then the biomass remains wet, and boiler efficiency suffers.

The woody storage time (in purple) shows a peak (at 16 weeks) just below the base case value (20 weeks) where the effects of moisture loss and degradation are optimally balanced. If the woody storage time is too short, the biomass remains wet, and boiler efficiency is low. However, if the woody storage time is too long, then there is no additional drying beyond the equilibrium moisture content, and degradation impacts mount up (losing biomass and so chain efficiency) – eventually reaching a plateau at a maximum degradation level.

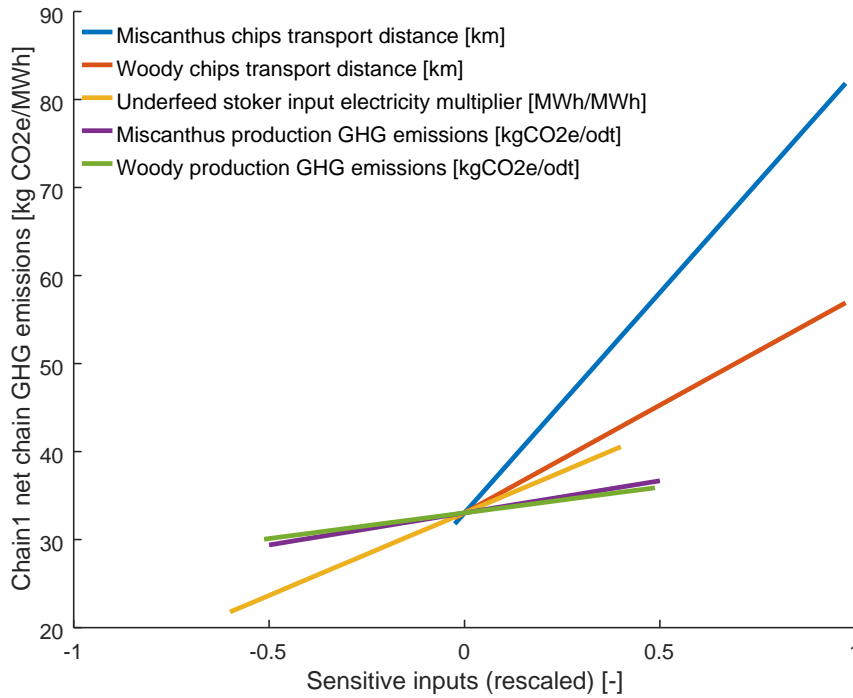

Figure 4.53: Chain 1 GHG emissions sensitive parameters spider chart

All of the main parameters contributing to the Chain 1 GHG emissions obey linear relationships. The electricity required by the underfeed stoker boiler is the parameter which has the greatest potential for reducing GHG emissions, were this electricity input minimised. As expected, both the chip transport distances should be kept low, but with little scope for GHG emissions improvement below the base case. The GHG emission contributions from the production of the feedstocks do not have a major impact, with that of growing Miscanthus being slightly more sensitive (slightly less flat) than growing the generic Woody feedstock. All the single parameter variations considered would still be compliant with the current RHI GHG emissions threshold (125 kgCO₂e/MWh_{th}), suggesting plenty of headroom for different supply chain options/parameter values to be considered.

4.6.2 Chain 2 – Underfeed stoker combustion boiler with screening and field washing

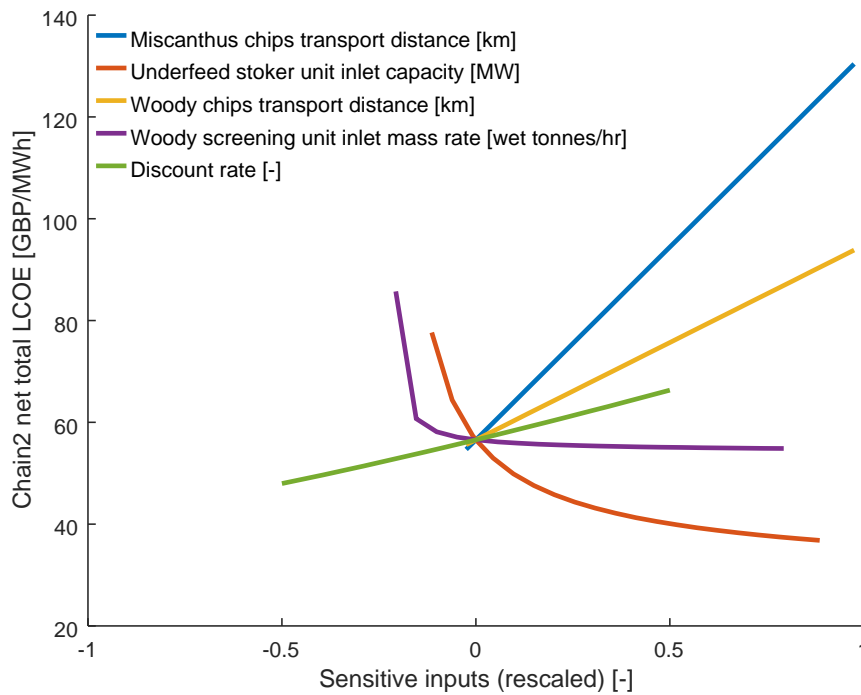

Figure 4.54: Chain 2 LCOE sensitive parameters spider chart

This Chain 2 LCOE spider diagram is very similar to the Chain 1 LCOE spider diagram (which is to be expected, given the very similar pie charts). The greatest improvements in LCOE are available from moving to larger boilers and screening units, and achieving lower discount rates (i.e. cheaper financing as the technology becomes more established, or with more certain policy).

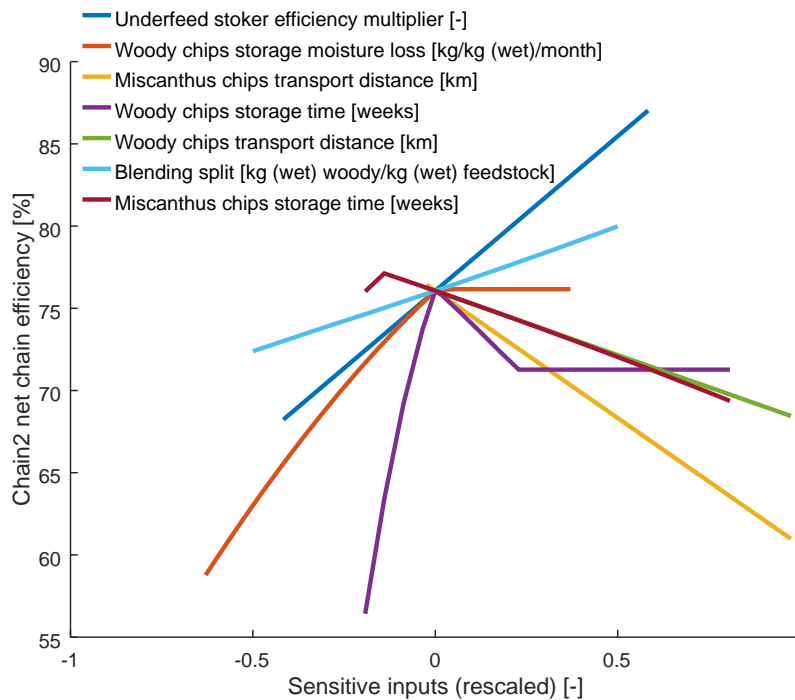

Figure 4.55: Chain 2 net efficiency sensitive parameters spider chart

Compared to same net efficiency spider chart for Chain 1, maximising the boiler efficiency and minimising the use of Miscanthus (and avoiding long transport distances) remain the key methods of maximising Chain 2 net efficiency.

However, due to the addition of moisture via field washing, several of the storage parameters have shifted or become more sensitive. In Chain 2, the Miscanthus chips are now best stored to dry out naturally for 2 weeks after field washing before use in a boiler – whereas in Chain 1, the Miscanthus chips are best used immediately, to avoid any degradation. The woody chip optimum storage time is now slightly later (now happens to be at the base case value of 20 weeks). Shorter storage times lead to a rapid drop-off in efficiency (biomass is too wet), and the wetter biomass also means the degradation rate is slightly higher, as seen for long storage times. Furthermore, the woody chips only reach the equilibrium moisture content (20% moisture) at a higher moisture loss rate, which makes sense due to the wetter starting point.

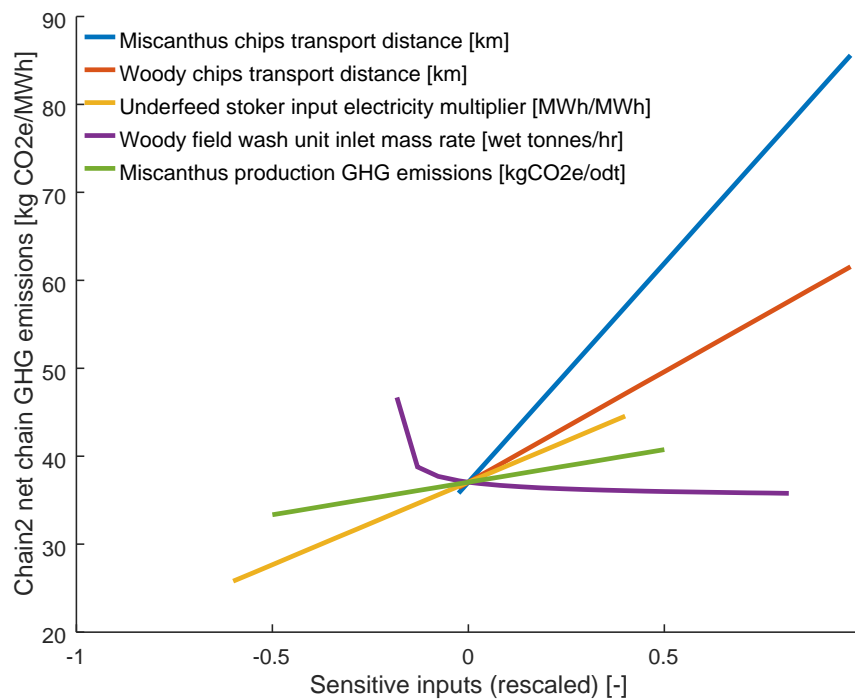

Figure 4.56: Chain 2 GHG emissions sensitive parameters spider chart

The sensitive parameters for GHG emissions in Chain 2 include the same linear parameters as in Chain 1, except for explicit inclusion of the woody field wash unit capacity. This parameter introduces a non-linear relationship, with little potential for optimisation at larger scales, but with a relatively strong increase in GHG emissions at scales below ~5 wet tonnes/hr (due to proportionally higher power use as equipment scale is reduced towards the minimum of 0.5 wet tonnes/hr). The greatest benefit are still achieved by minimising the underfeed stoker boiler power use, and starting feedstock production GHG emissions. All the single parameter variations considered would still be compliant with the current RHI GHG emissions threshold (125 kgCO₂e/MWh_{th}), still suggesting plenty of headroom for different supply chain options/parameter values to be considered.

4.6.3 Chain 3 – BFB gasifier + syngas engine with screening

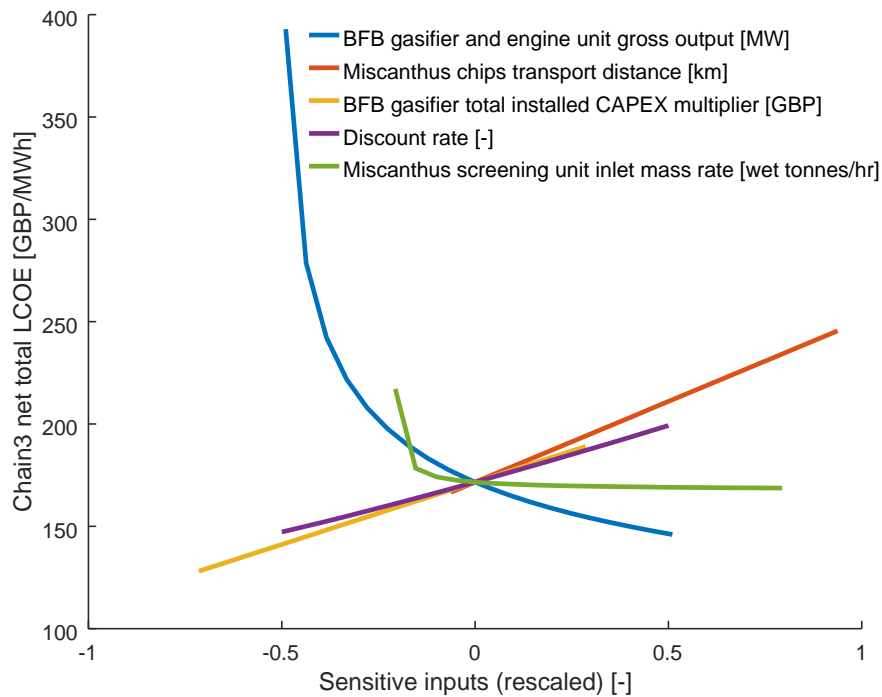

Figure 4.57: Chain 3 LCOE sensitive parameters spider chart

It can be seen that the contribution of the BFB gasifier + engine unit gross output (i.e. conversion unit capacity) is a particularly strong driver of Chain 3 LCOE. Due to its exponential scaling, small conversion units will have high levelised CAPEX, and low efficiencies, leading to extremely high chain costs. Conversely, larger conversion units have considerable potential to reduce LCOE. For context, the base case gross unit capacity is 5MW_e, with a min-max range of 0.2 – 10MW_e (although the parasitic power losses need to then be subtracted from this value).

Other beneficial changes to the Chain 3 LCOE include minimisation of the BFB gasifier CAPEX, and discount rate. High transport distances and low screening capacities also need to be avoided.

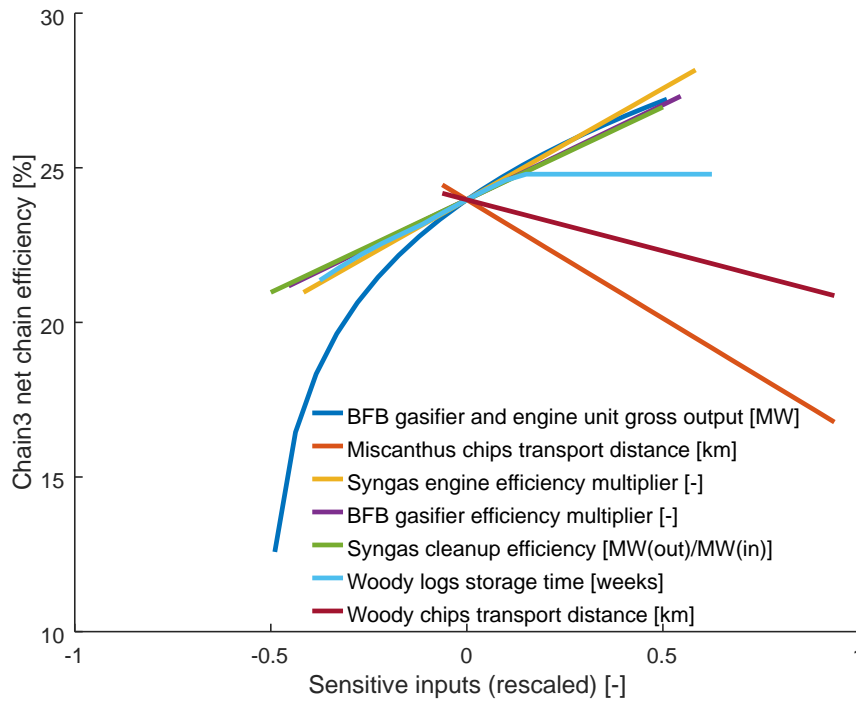

Figure 4.58: Chain 3 net efficiency sensitive parameters spider chart

The efficiencies of the three conversion technology sub-units (yellow, purple and green lines) all have a very similar linear effect on the Chain 3 net efficiency, and each of these need to be maximised to achieve the highest Chain 3 net efficiencies. As discussed above for the LCOE spider chart, the conversion unit capacity is the main driver of the net chain efficiency with a particularly severe reduction in efficiency occurring at lower scales (in part due to the syngas engine efficiency falling with scale, and in part due to still needing to meet parasitic loads onsite which do not fall with scale as quickly).

If woody logs were stored for slightly longer (106 weeks instead of 76 weeks), then the chain efficiency would be higher, as the moisture equilibrium limit (at 20% moisture) would then be reached. Long transport distances consume significant amounts of diesel, lowering the net chain efficiency.

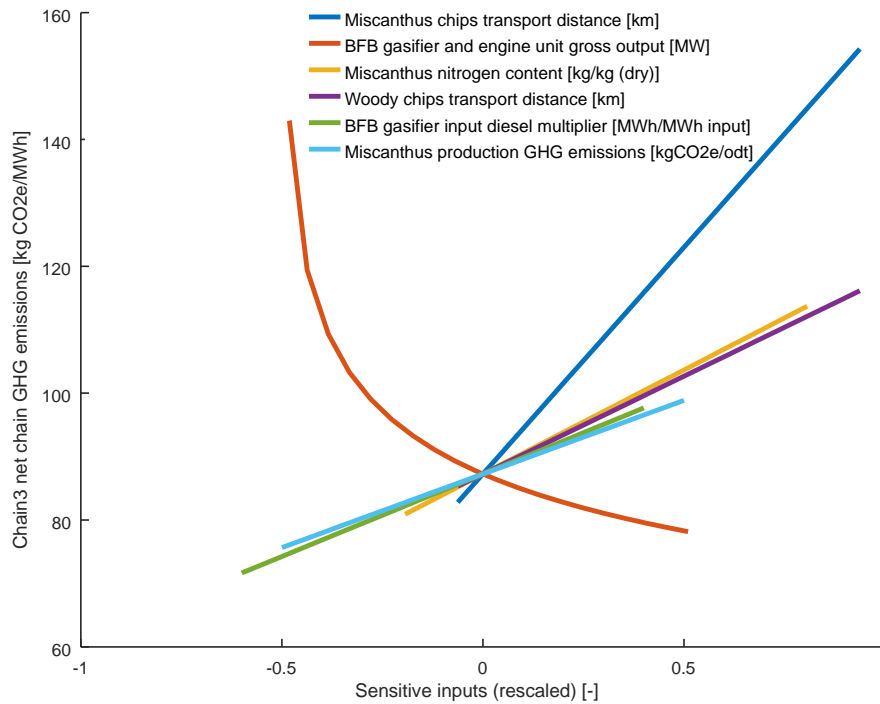

Figure 4.59: Chain 3 GHG emissions sensitive parameters spider chart

The largest reduction in the GHG emissions for Chain 3 can be achieved by reducing the amount of diesel required by the BFB gasifier unit for start-up cycles²³, and by minimising the GHG emissions associated with growing the Miscanthus and woody feedstocks (either by minimising the inputs and machinery used, and/or maximising yields). In order to keep GHG emissions low (for example, below an arbitrary value of 120kgCO_{2e}/MWh_e), it is also important to avoid small conversion unit capacities (<~0.65MW_e) and to avoid high transport distances (>~420km for Miscanthus).

The Miscanthus nitrogen content could potentially be significantly higher than its base case value, leading to substantial increases in chain GHG emissions due to extra urea use – however, the ability to make GHG savings by minimising the Miscanthus nitrogen content below the base case is limited.

All the single parameter variations considered would still be compliant with the current RO GHG emissions threshold (240 kgCO_{2e}/MWh_e), and even with the post-2025 threshold (180 kgCO_{2e}/MWh_e), suggesting plenty of headroom for different supply chain options/parameter values to be explored.

²³ TEABPP models plant availability, and opex is correlated to downtime, but the number of start-up cycles is not explicitly modelled.

4.6.4 Chain 4 – BFB gasifier + syngas engine with water washing and pelleting

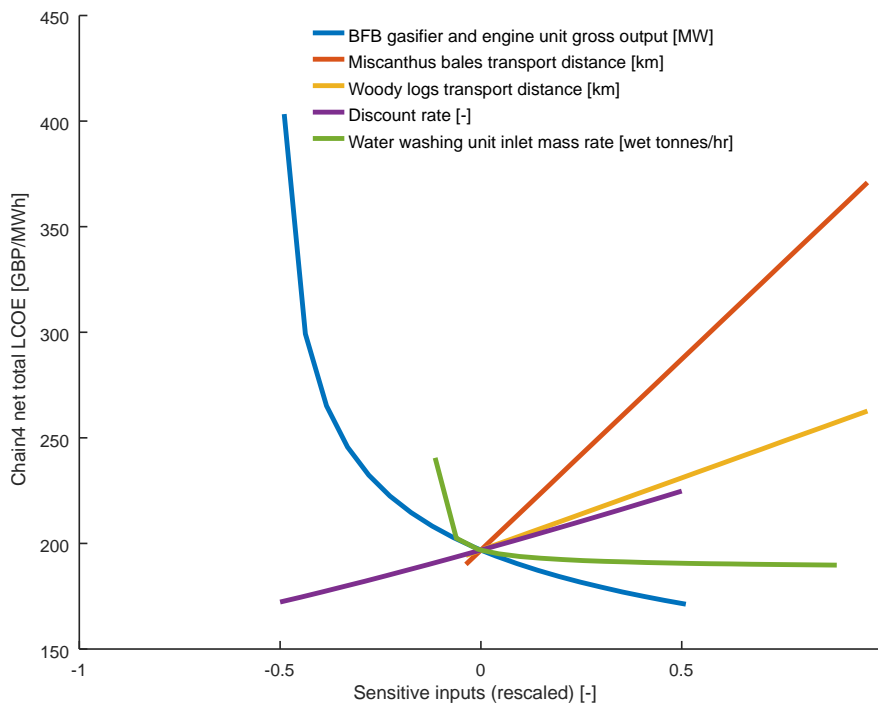

Figure 4.60: Chain 4 LCOE sensitive parameters spider chart

The LCOE spider chart for Chain 4 is similar to the one for LCOE for Chain 3, except now the gradients for the transport distance parameters are now much steeper (due to the smaller truck size used in Chain 4 for the initial aggregation to the pre-processing plant). In order to keep LCOE low (for example, below the base case LCOE of 197 £/MWh_e), it is also important to avoid small conversion unit capacities (<5MW_e) and to avoid small water washing unit capacities (<10tonnes/hr). Larger conversion units (>5MW_e) and lower discount rates (<10%) have considerable potential to reduce the Chain 4 LCOE.

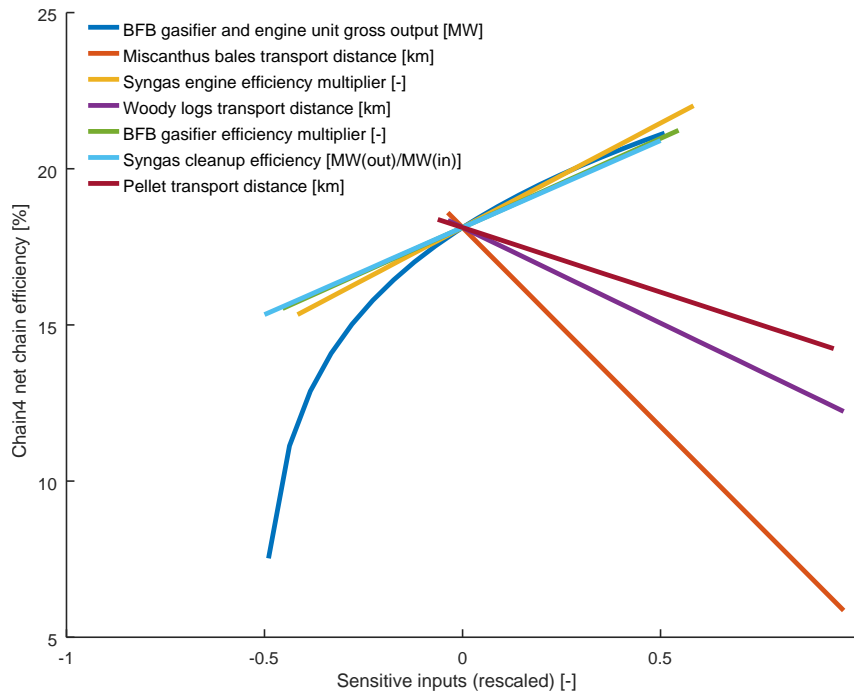

Figure 4.61: Chain 4 net efficiency sensitive parameters spider chart

The Chain 4 net efficiency spider chart (Figure 4.61) is very similar to the equivalent chart for Chain 3, except that the pellet transport distance is now also present, and the transport distances for the raw feedstocks have increased (as explained above).

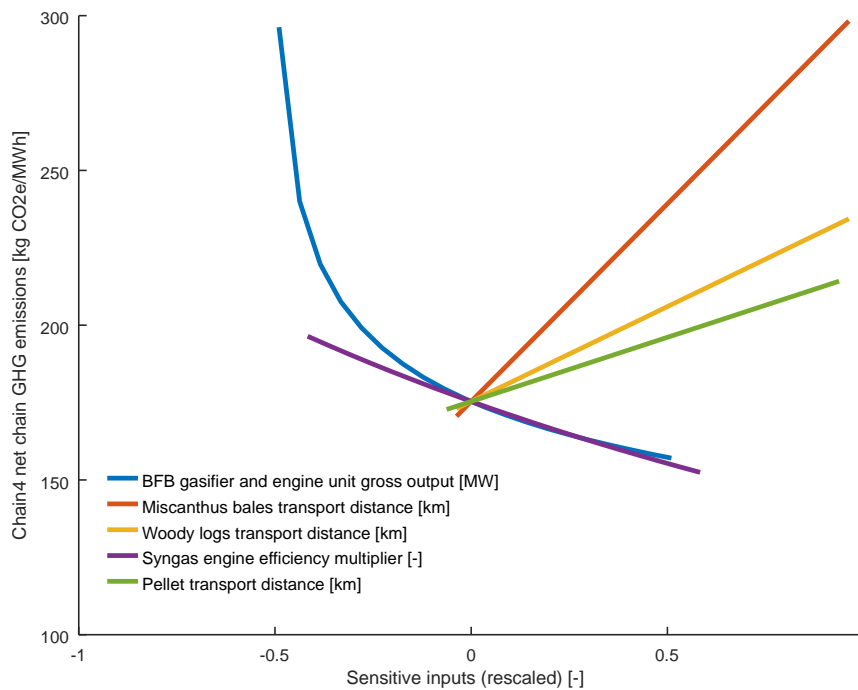

Figure 4.62: Chain 4 GHG emissions sensitive parameters spider chart

The increased importance of the transport distances in Chain 4 means that the relative importance of other parameters (feedstock nitrogen content, diesel start-up use in the BFB gasifier, and the GHG emissions from Miscanthus and woody feedstock production) are no longer shown explicitly on this chart – but still are important to Chain 4. The smallest chain GHG emissions are achievable at large

conversion unit scales, and with high syngas engine efficiencies – noting that the syngas engine efficiency also increases with scale.

Small conversion systems or chains with long transport distances would struggle to be compliant with the current RO GHG emissions threshold (240 kgCO₂e/MWh_e), and especially after 2020 or 2025 when the threshold falls to 200 and then 180 kgCO₂e/MWh_e. This post-2025 threshold is only just above the current Chain 4 base case GHG emissions value of 175 kgCO₂e/MWh_e, suggesting limited headroom for different supply chain options to be considered, or that improvements in Chain 4 may be necessary, unless there is rapid UK grid decarbonisation²⁴.

4.6.5 Chain 5 – CFB combustion boiler with screening

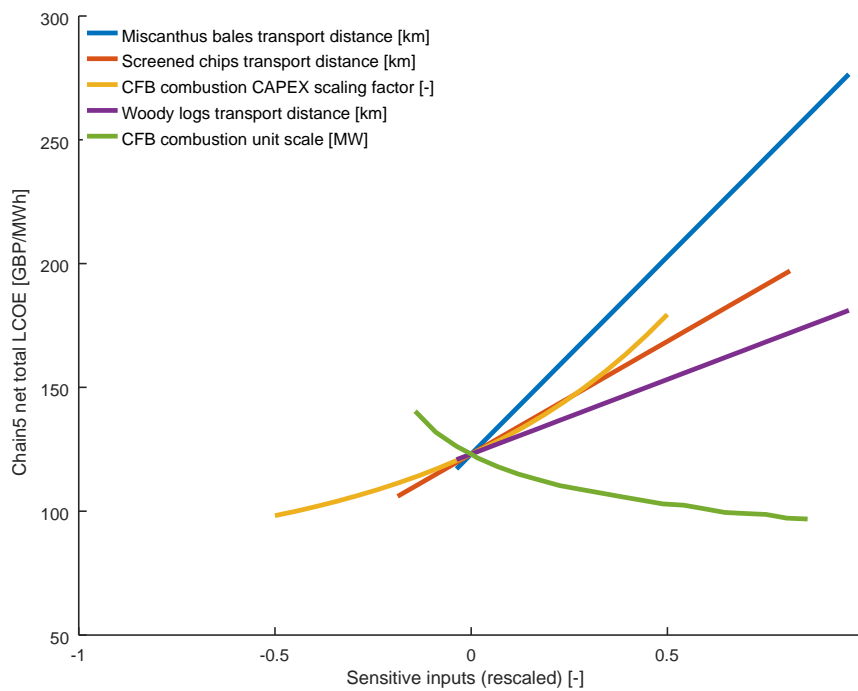

Figure 4.63: Chain 5 LCOE sensitive parameters spider chart

From this Chain 5 LCOE spider chart it can, again, be seen that the transport distances must be kept low to keep the LCOE reasonable. Reducing the CFB combustion CAPEX scaling factor (i.e. effectively minimising the CFB combustion CAPEX at a given scale), and increasing the scale of the CFB plant are the best ways to reduce chain LCOE – for context the base case CFB plant scale is 100MW_e, but could go up to 400MW_e. The 150km distance assumed for transporting the screened chips could also be reduced as a way of lowering chain LCOE.

²⁴ Note that as the TEABPP project is only scoped to look at current costs, emissions and performance, we have not looked at future UK power grid decarbonisation scenarios in particular years (e.g. 2030). Lower grid GHG intensities will lower Chain 4 GHG emissions to some extent, giving some extra headroom, but this has not been quantified.

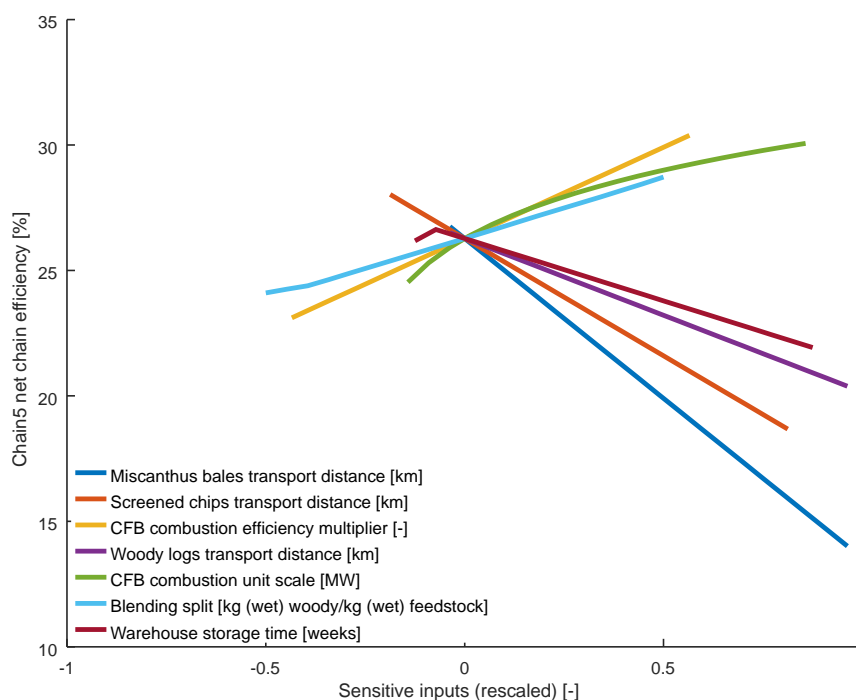

Figure 4.64: Chain 5 net efficiency sensitive parameters spider chart

The two parameters most able to most improve the Chain 5 net efficiency are large conversion unit capacity (as this drives higher plant efficiencies), and a high efficiency multiplier (i.e. towards the top end of the uncertainty range in CFB plant efficiencies available).

Choosing woody over Miscanthus feedstocks also increases net chain efficiency, due to the diesel use in transporting bales or Miscanthus chips, compared to logs and woody chips (higher densities), as well as some CFB combustion benefits²⁵. The warehouse storage time can also be optimised for the feedstock blend, choosing 4 weeks instead of the base case 13 weeks to best balance drying of the 50:50 blended feedstocks with degradation losses.

²⁵ Note that some of the efficiency gain when choosing woody over Miscanthus is however to do with LHV efficiency accounting – if you start with a much wetter feedstock, and allow natural drying, this storage step can have an efficiency of 120% (or higher), because the drier output biomass has a much higher LHV. Effectively, you are getting the sun’s energy for free in driving off the woody moisture during storage – but this benefit is not available to already dry Miscanthus.

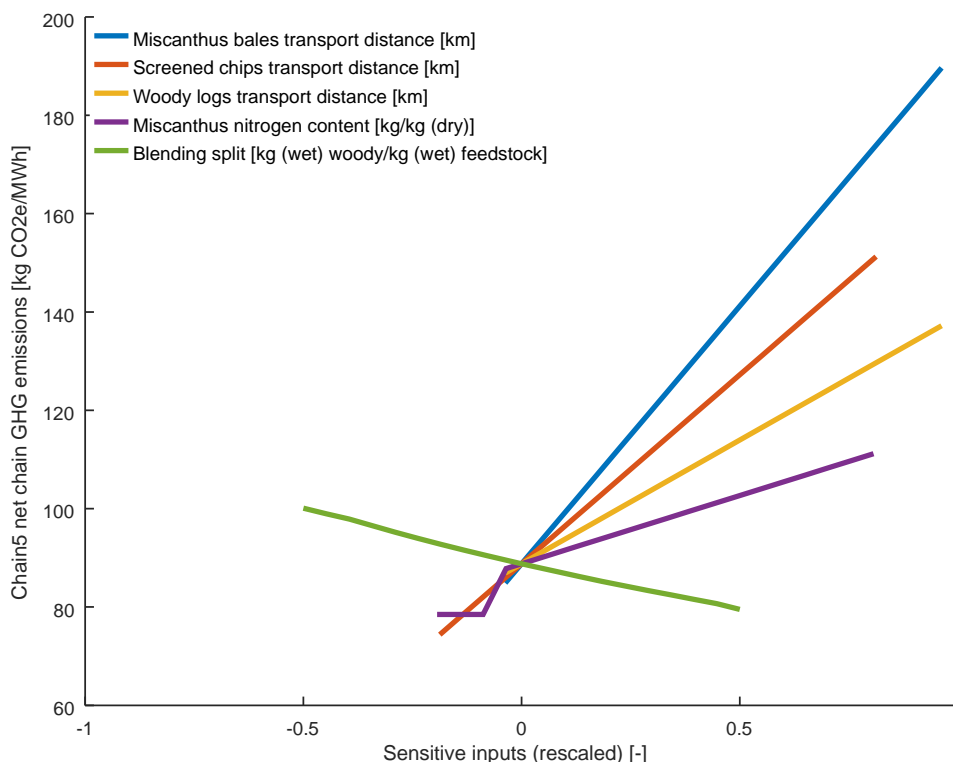

Figure 4.65: Chain 5 GHG emissions sensitive parameters spider chart

The blending split also has an impact on the Chain 5 GHG emissions, with a strong preference for woody over Miscanthus feedstocks if looking to minimise GHG emissions. This is partly to do with the slightly higher base case GHG emissions in producing Miscanthus, but mostly to do with the efficiency impacts discussed above (particularly the diesel use in transporting bales). For similar reasons, high transport distances need to be avoided to keep GHG emissions low.

At high feedstock nitrogen contents, a large amount of urea is required, adding to the GHG emissions. However, at very low feedstock nitrogen contents (assumed at <0.3%²⁶), the SNCR kit is assumed to no longer be required to control NO_x, and hence there is no urea use. This discontinuity is seen in the purple line for Miscanthus nitrogen content. Were only 100% Miscanthus used, this purple line would likely be twice as steep, i.e. would be a more important impact (due to no blending dilution of feedstock parameter effects).

Only chains with very long transport distances and high use of Miscanthus bales might struggle to be compliant with the post-2025 RO GHG emissions threshold (180 kgCO₂e/MWh_e), but otherwise the current base case is well below the thresholds, suggesting plenty of headroom for different supply chain options/parameter values to be considered.

²⁶ 0.3% is the feedstock nitrogen content limit below which SNCR kit is assumed to not be required, resulting in 7% capex and opex savings. This was suggested by ETI reviewers in 2016, based on the [I2 pellet standard](#), and implemented as agreed with ETI.

4.6.6 Chain 6 – CFB combustion boiler with pelleting

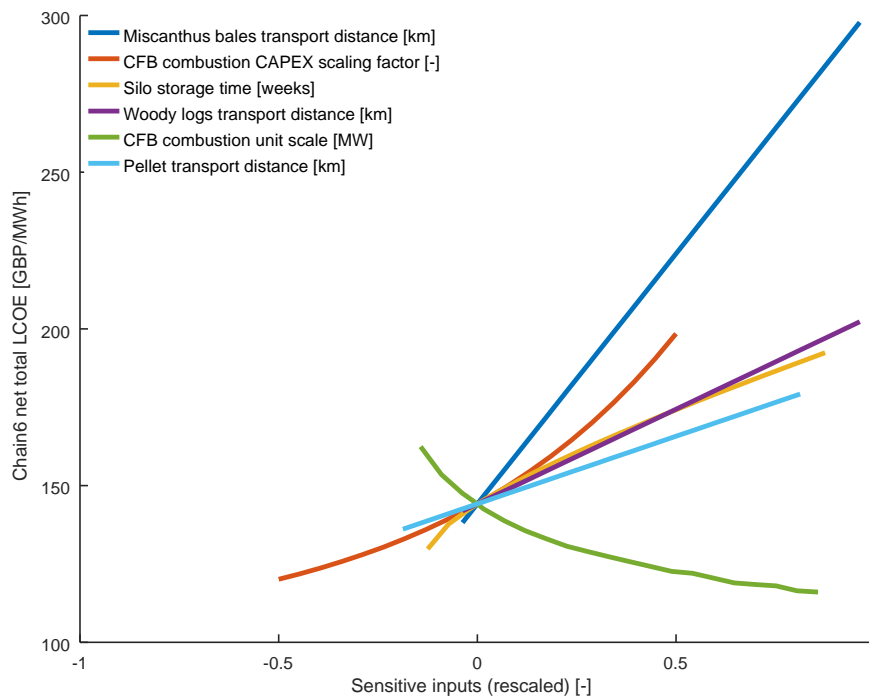

Figure 4.66: Chain 6 LCOE sensitive parameters spider chart

The effects of the input parameters on the LCOE of Chain 6 are similar to those in Chain 5, with the main differences being that the silo storage time should be kept as short as possible (to minimise silo costs), and the transport distance of the pellets should also be kept short. Reducing the CFB combustion CAPEX scaling factor (i.e. effectively minimising the CFB combustion CAPEX at a given scale), and increasing the scale of the CFB plant are still the best ways to reduce chain LCOE.

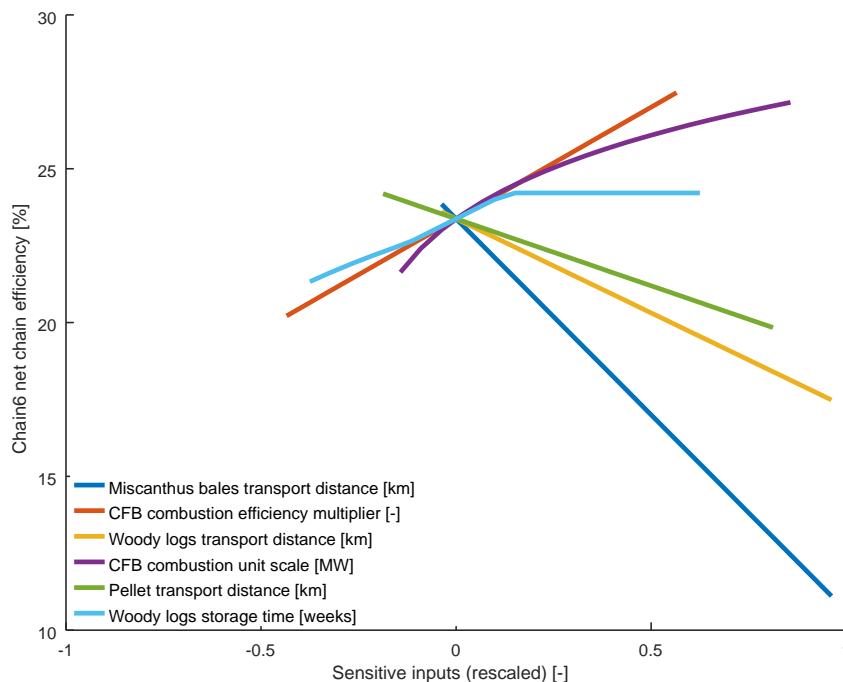

Figure 4.67: Chain 6 net efficiency sensitive parameters spider chart

The blending split has a smaller effect on the Chain 6 net efficiency than it does in Chain 5, as it no longer shows explicitly above (did not make the spider chart cut-off). This is because Chain 5 is transporting blended chips 150km (with a significant difference in density between Miscanthus chips or woody chips), and this change in diesel use impacts chain net efficiency. By contrast, Chain 6 transports uniform, high density pellets over 150km, and so the impact of the blending split on the chain net efficiency is small.

The two parameters most able to most improve the Chain 6 net efficiency are still a large conversion unit capacity and a high efficiency multiplier. Long distances (particularly Miscanthus bales) need to be avoided.

Similar to Chain 3, the woody log storage time, and therefore moisture content of the logs does have a small impact, and could be stored for longer to improve chain efficiency.

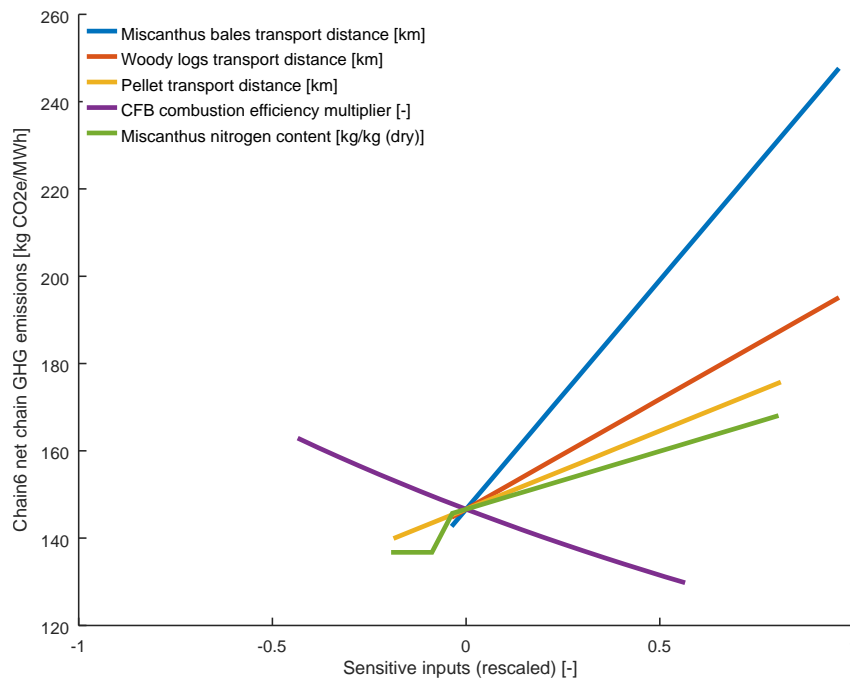

Figure 4.68: Chain 6 GHG emissions sensitive parameters spider chart

The results for the Chain 6 GHG emissions are also similar to those for Chain 5, although with the CFB combustor efficiency being slightly more important than the blending split (which is now not shown explicitly), albeit having a similar effect – i.e. achieving high conversion efficiencies is the best way to minimise chain GHG emissions. There is a similar discontinuous step for the Miscanthus nitrogen content, as in Chain 6.

Only chains with long transport distances might struggle to be compliant with the post-2025 RO GHG emissions threshold (180 kgCO₂e/MWh_e), but otherwise the current base case is comfortably below the thresholds, suggesting headroom for different supply chain options/parameter values to be considered.

4.6.7 Chain 7 – CFB combustion boiler with chemical washing and pelleting

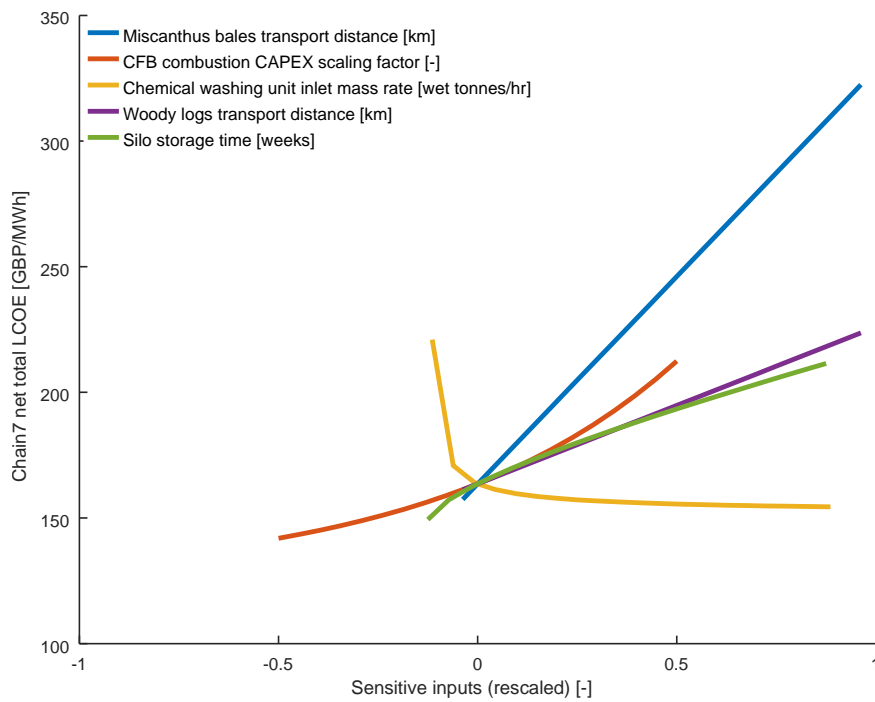

Figure 4.69: Chain 7 LCOE sensitive parameters spider chart

The main difference between Chains 7 and 6 regarding the LCOE is that for Chain 7, chemical washing plants that are smaller than the base case should be avoided to keep costs down. Reducing the CFB combustion CAPEX scaling factor (i.e. effectively minimising the CFB combustion CAPEX at a given scale) is still the best way to reduce chain LCOE – increasing the scale of the CFB plant would also decrease costs, but is not explicitly shown here (as it does not meet the 5% cut-off).

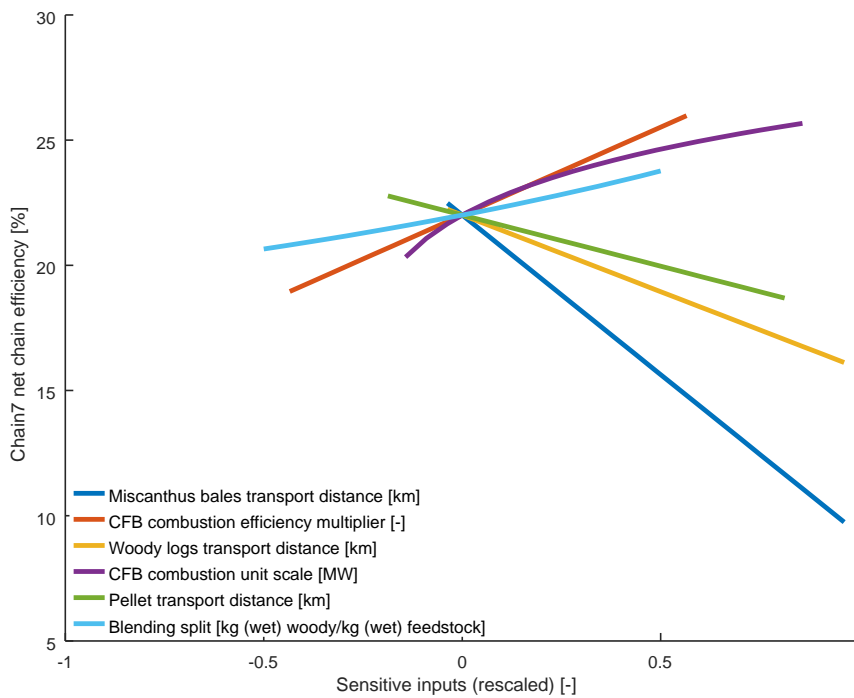

Figure 4.70: Chain 7 net efficiency sensitive parameters spider chart

Similar to Chains 5 and 6, the two parameters most able to most improve the Chain 5 net efficiency are still a large conversion unit capacity and a high efficiency multiplier. Long distances (particularly Miscanthus bales) need to be avoided. Choosing woody over Miscanthus feedstocks also increases net chain efficiency, as in Chain 5 (and Chain 6, just not explicitly shown).

Since there is no moisture loss from pellets stored in silos, and degradation rates are very low, the silo storage time does not appear on this chart (compared to the warehouse storage time appearing the Chain 5 efficiency spider chart).

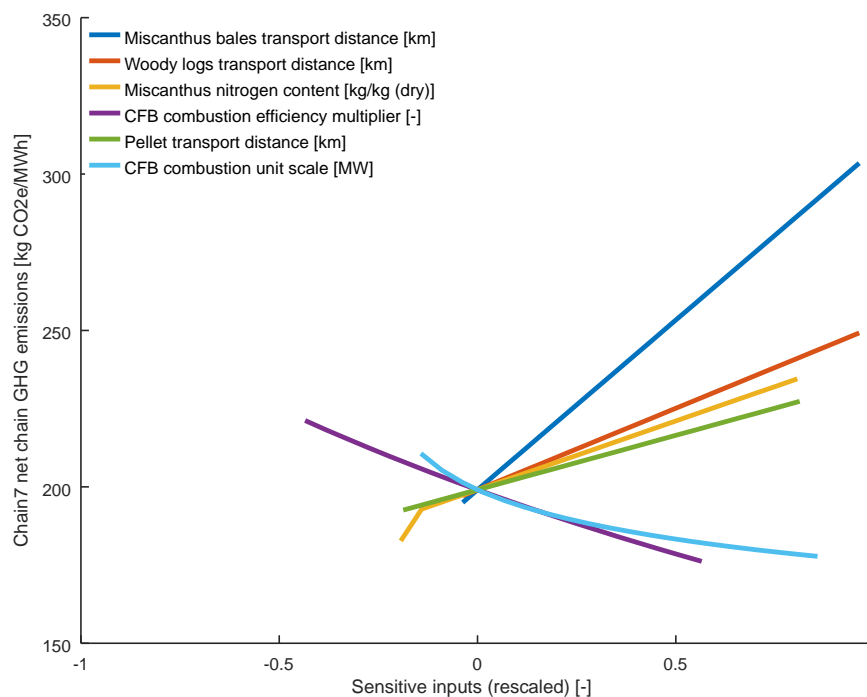

Figure 4.71: Chain 7 GHG emissions sensitive parameters spider chart

The Chain 7 GHG emissions spider chart shows that both larger CFB conversion unit scale and higher conversion efficiencies have an important role in lowering GHG emissions.

The Miscanthus nitrogen content (in the starting feedstock) is much more sensitive than in Chain 5 or 6, with a steeper gradient (note the y-axis goes up to much larger values than in the equivalent Chain 5 or 6 charts). This is because chemical washing increases the biomass nitrogen content. This also means that the step for which SNCR and urea are no longer required has been significantly shrunk – it is now only the very smallest starting feedstock nitrogen contents that can avoid the urea GHG emissions hit.

Chains with long transport distances would struggle to be compliant with the current RO GHG emissions threshold (240 kgCO₂e/MWh_e). However, after 2020 or 2025 when the threshold falls to 200 and then 180 kgCO₂e/MWh_e, Chain 7 will be at severe risk of being non-compliant, as the current base case is 199 kgCO₂e/MWh_e. In the absence of rapid UK grid decarbonisation, this suggests that only certain chain options/parameter options can be considered, and significant work may have to go into decreasing various chemical and energy inputs.

4.6.8 Chain 8 – EF gasifier + syngas CCGT with pelleting

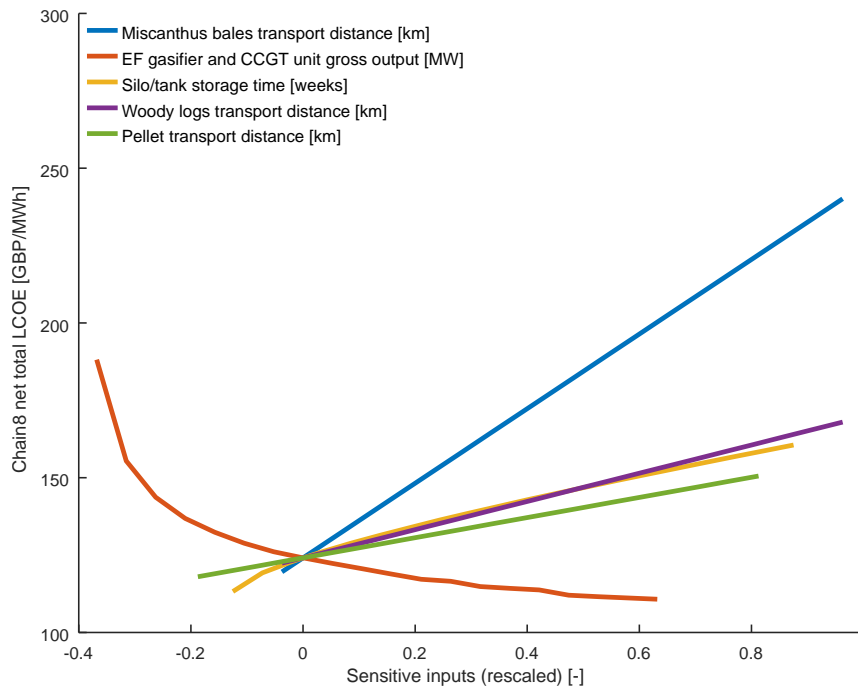

Figure 4.72: Chain 8 LCOE sensitive parameters spider chart

From this Chain 8 LCOE spider chart it can, again, be seen that the transport distances must be kept low to avoid high LCOE values. As in Chain 6, silo storage time should be kept as short as possible (to minimise silo costs). Increasing the scale of the EF gasifier + CCGT conversion plant is the best way to reduce chain LCOE – for context the base case conversion plant gross output is 300MW_e, but could go up to 755MW_e (before parasitic loads are then considered). Smaller plants <100MW_e are to be avoided, given the high levelised CAPEX and lower CCGT efficiency.

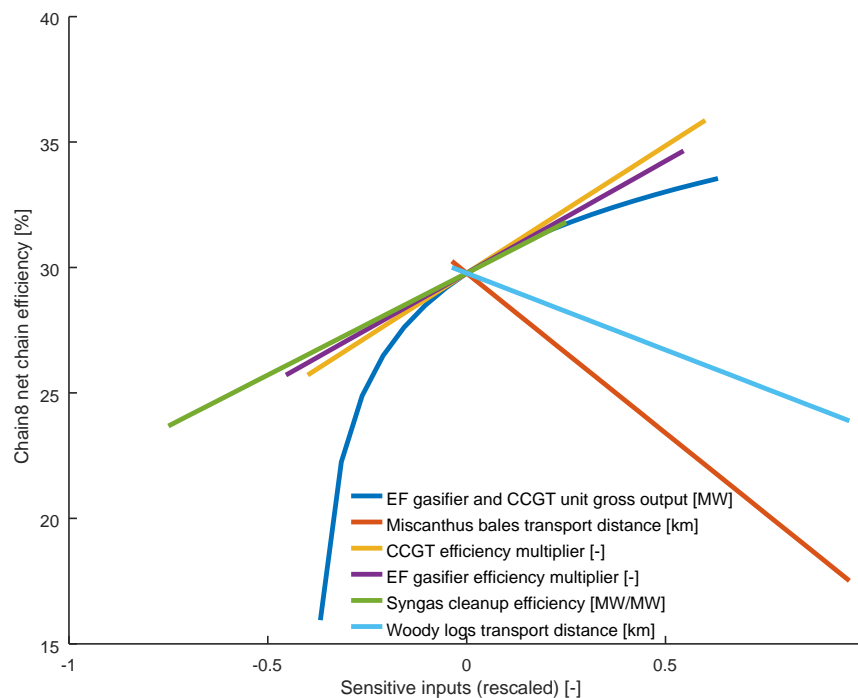

Figure 4.73: Chain 8 net efficiency sensitive parameters spider chart

Regarding the net chain efficiency for Chain 8, the scale of the conversion unit is very important, as the efficiency drops off rapidly as the scale is decreased below the base case value.

Increasing the efficiency of the CCGT and EF gasifier sub-units would lead to the greatest overall improvement in net chain efficiency. The assumed base case value for the efficiency of the syngas clean-up (the third sub-unit) is relatively high, as shown by the shift to the left of the green line, and so there is less potential for improvement.

Overall, this chart is fairly similar to the equivalent chart for Chain 3, although in general the efficiencies shown are higher for Chain 8 than in Chain 3.

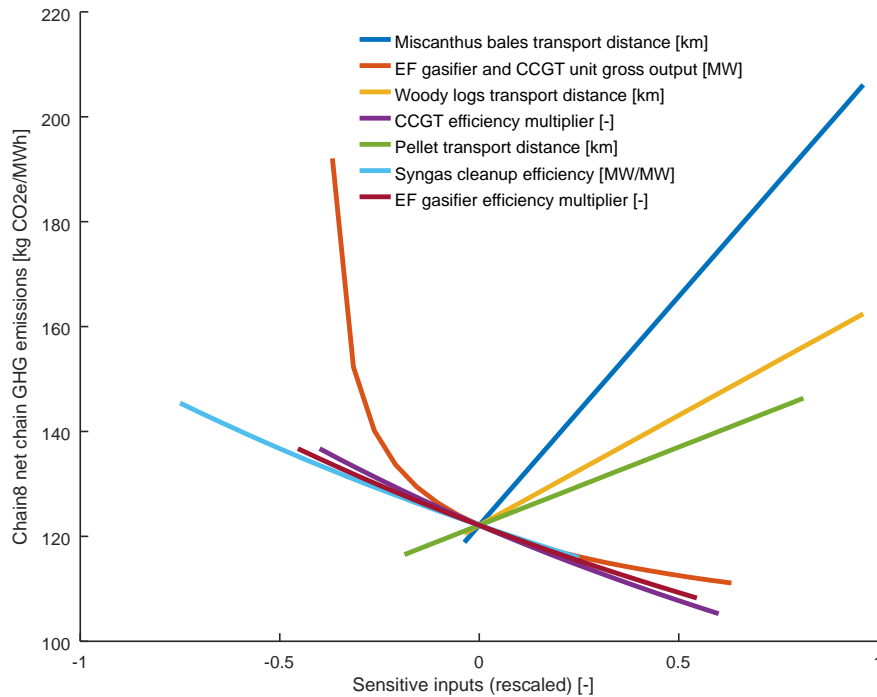

Figure 4.74: Chain 8 GHG emissions sensitive parameters spider chart

Achieving low GHG emissions for Chain 8 requires a similar set of conditions or improvements as discussed for the Chain 8 net efficiency spider chart – this GHG emissions chart is effectively the efficiency chart but turned upside down (higher efficiencies mean lower GHG emissions). The presence of pellet transport distance requires minimising where possible.

Only chains with long transport distances might struggle to be compliant with the post-2025 RO GHG emissions threshold (180 kgCO₂e/MWh_e), but otherwise the current base case is comfortably below the thresholds, suggesting headroom for different supply chain options/parameter values to be considered.

4.6.9 Chain 9 – EF gasifier + syngas CCGT with torrefaction + pelleting

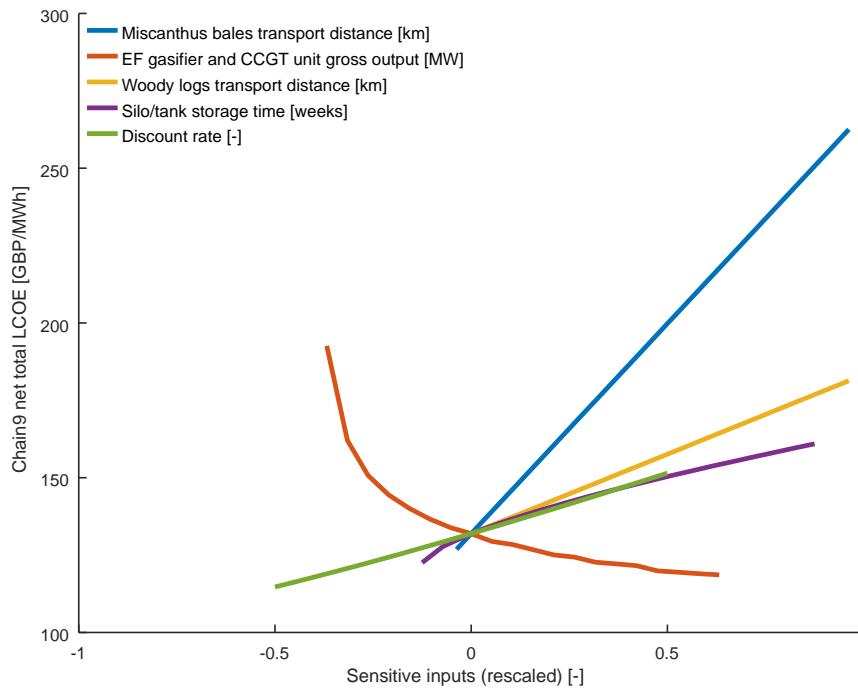

Figure 4.75: Chain 9 LCOE sensitive parameters spider chart

The trends here are very similar to those in the Chain 8 LCOE spider chart, and increasing the scale of the EF gasifier + CCGT conversion plant is the best way to reduce chain LCOE. There is one (explicit) addition to the chart, with a lower discount rate shown to be able to reduce the LCOE. Discount rate reductions are also important to Chain 8, but do not quite meet the 5% cut-off to be shown. The pellet transport distance still has an impact in Chain 9, but this impact is reduced to less than the 5% cut-off due the higher energy density of the torrefied pellets.

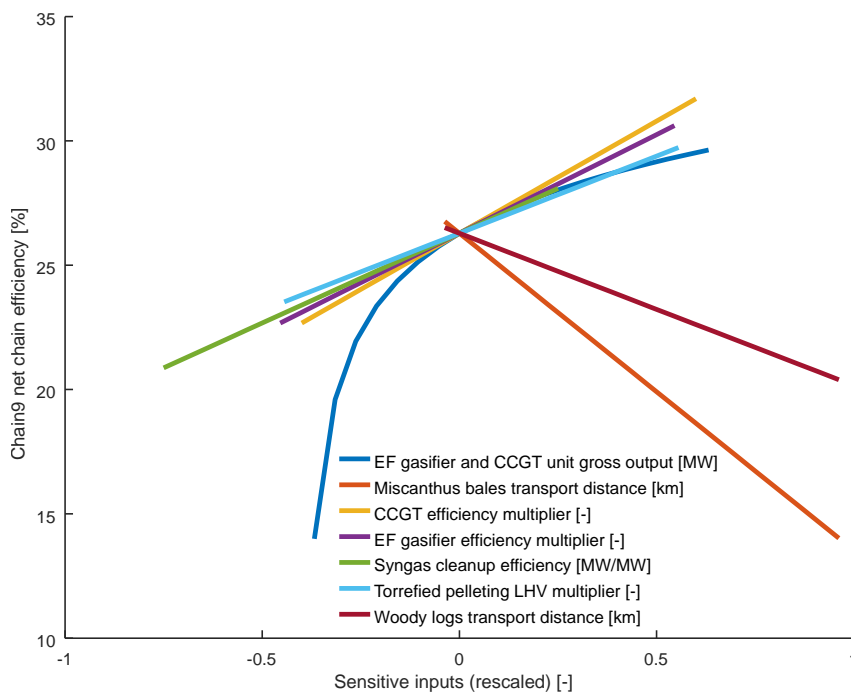

Figure 4.76: Chain 9 net efficiency sensitive parameters spider chart

Overall, this Chain 9 net efficiency spider chart is fairly similar to the equivalent chart for Chain 8. The conversion unit scale and conversion sub-unit efficiencies have the same impacts as in Chain 8, and should all be maximised in order to maximise the Chain 9 net efficiency. In addition, the torrefied pelleting LHV multiplier²⁷ shows a linear relationship, as the higher LHV of the pellets translates into less diesel use in trucking, and hence higher net chain efficiency.

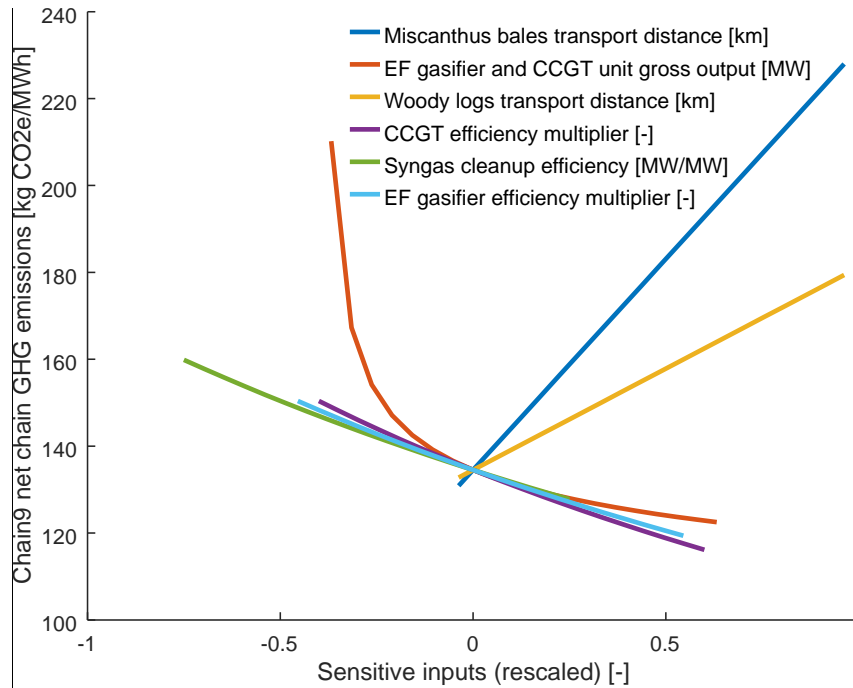

Figure 4.77: Chain 9 GHG emissions sensitive parameters spider chart

Almost all of the parameters plotted on the Chain 9 net efficiency spider chart appear here (inverted) on the Chain 9 GHG emissions spider chart. The conversion unit scale and conversion sub-unit efficiencies have the same impacts as in Chain 8, and should all be maximised in order to minimise the Chain 9 GHG emissions. However, as discussed for the Chain 9 pie charts, the torrefied pelleting LHV multiplier and the pellet transport distance are not plotted on the Chain 9 GHG emissions spider chart, since the torrefied pellets reduce the final transport step GHG emissions from diesel consumption enough that the sensitivities to the torrefaction+pelleting plant parameters and pellet transport distance are sufficiently reduced to now no longer be explicitly plotted.

Only chains with very long transport distances or very small conversion plant capacities might struggle to be compliant with the post-2025 RO GHG emissions threshold (180 kgCO₂e/MWh_e), but otherwise the current base case is comfortably below the thresholds, suggesting headroom for different supply chain options/parameter values to be considered.

²⁷ This multiplier is a parameter at the start of the formula that calculates the output torrefied pellet LHV based on the input feedstock LHV (in GJ/odt), and reflects uncertainty and variability in torrefaction+pelleting operating conditions. The base case for the multiplier = 1.09, i.e. torrefied pellets in the base case have an LHV that is 9% higher than the input feedstock LHV. So, taking a new value of 1.199 for the multiplier creates a torrefied pellet LHV that is 19.9% higher than the input feedstock LHV, and is $(1.119/1.09 - 1 =)$ 10% above the base case torrefied pellet LHV.

4.6.10 Chain 10 – EF gasifier + syngas CCGT with pyrolysis

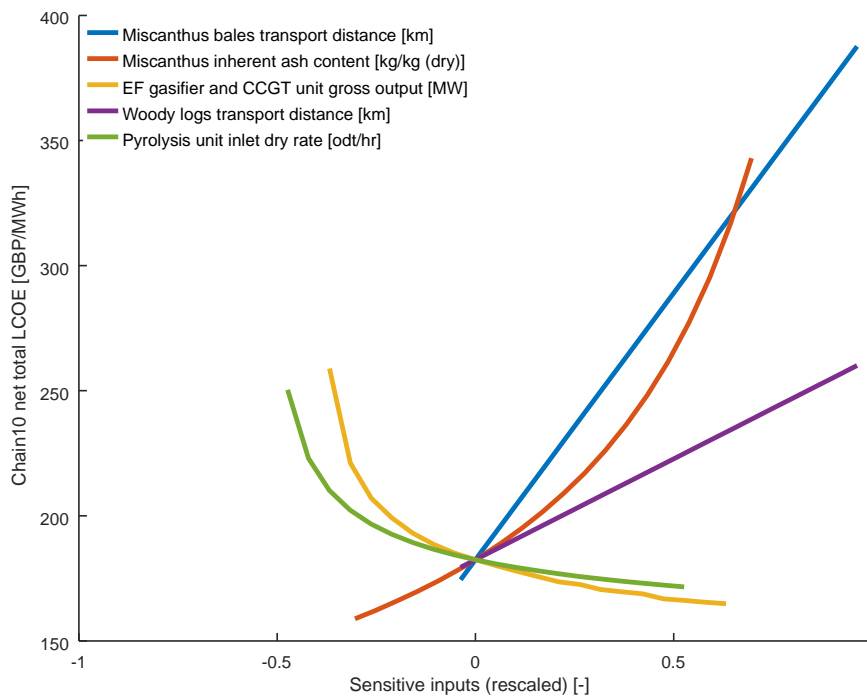

Figure 4.78: Chain 10 LCOE sensitive parameters spider chart

For Chain 10, the ash content of the Miscanthus feedstock has a very large and exponential effect on the chain LCOE, due to higher ash content reducing the pyrolysis efficiency (yields of bio-oil are significantly reduced in favour of biochar/solid fractions). The ash content of the woody feedstock will also impact, but given its min-max range is smaller than that of Miscanthus, it is not significant enough to meet the 5% cut-off for plotting. Minimising the feedstock ash content that goes into the pyrolysis unit is therefore an effective way to reduce LCOE.

Increasing the scales of the EF gasifier + CCGT conversion plant and of the pyrolysis unit are also important methods to reduce the chain LCOE, and small unit scales should be avoided – as should high transport distances.

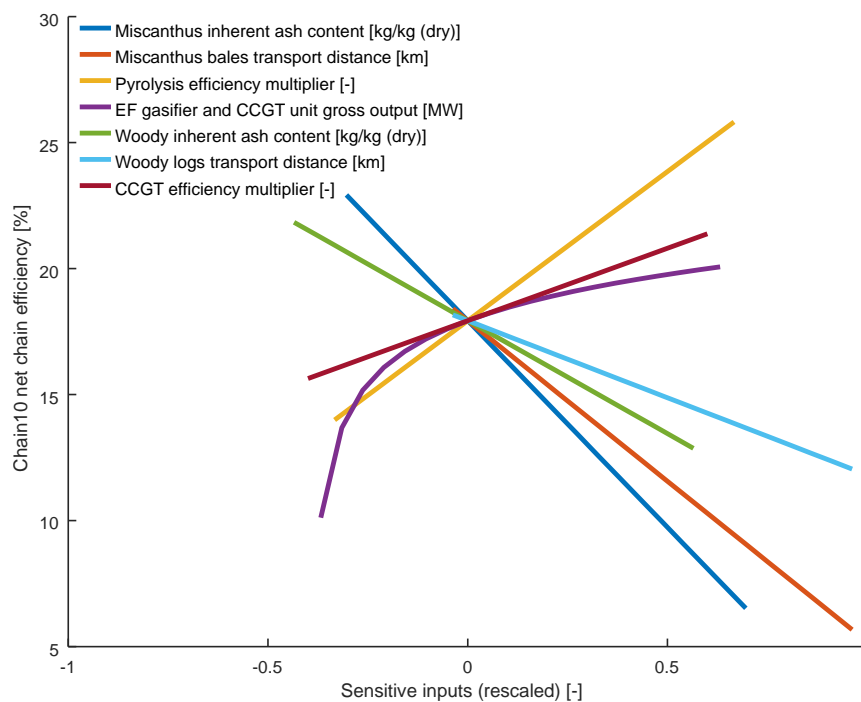

Figure 4.79: Chain 10 net efficiency sensitive parameters spider chart

The inherent ash contents of both feedstocks are important when looking at the Chain 10 net efficiency, and show a linear relationship (as parameterised in the pyrolysis module). These ash contents need to be minimised if looking to maximise the chain net efficiency – which is starting from a lower base case than the rest of the TEABPP chains. The importance of the pyrolysis efficiency to Chain 10 is confirmed by the chart showing that the largest efficiency improvements come from increasing the pyrolysis efficiency multiplier²⁸.

The conversion unit scale and CCGT efficiencies also have important impacts. It is noticeable that the y-axis goes down as far as only 5% net chain efficiency – i.e. there are several parameters choices that could leave Chain 10 generating little more in electricity than it consumes in other energy inputs – and this is without TEABPP quantifying the energy used in feedstock production²⁹ (as explicit modelling of the feedstock production step is outside of the TEABPP scope).

²⁸ This multiplier is a parameter at the start of the pyrolysis efficiency formula that reflects the uncertainty and variability in pyrolysis unit efficiencies. The base case for the pyrolysis efficiency multiplier = 1.00. So, taking a new value of 1.10 for the multiplier increases the pyrolysis unit efficiency by 10% (not %-points) above the base case pyrolysis unit efficiency.

²⁹ Each feedstock enters the TEABPP model system boundary at the farm/forest gate, accompanied by their physical and chemical characteristics, a single cost value, and a single GHG emissions factor (that encompasses establishment, cultivation and harvesting of that feedstock, following the RHI/RO methodology). “Feedstock production” is therefore everything upstream of the TEABPP model. The TEABPP model therefore does not have any parameters corresponding to inputs (e.g. diesel) to the feedstock production step, and so TEABPP cannot quantify how much energy is consumed in producing each feedstock. The chain net energy efficiencies for generating power or heat in TEABPP are therefore calculated from the farm/forest gate, and not from the rhizome/cutting/sapling. However, the chain GHG emissions in TEABPP encompass the whole chain from planting to end vector, and are consistent with the RHI/RO GHG methodology, due to the use of a feedstock GHG emissions factor (from the Ofgem/E4tech Solid & gaseous biomass carbon calculator).

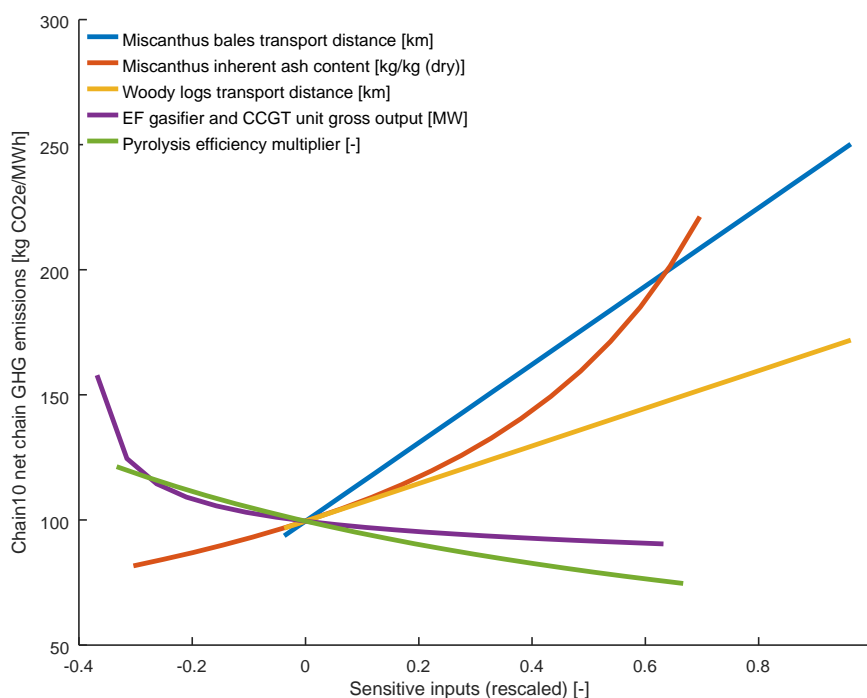

Figure 4.80: Chain 10 GHG emissions sensitive parameters spider chart

In many ways, this chart is similar to the Chain 10 LCOE spider chart, although instead of the pyrolysis unit scale being shown, the pyrolysis efficiency multiplier is plotted, as this has a more direct role on the chain efficiency, and hence GHG emissions.

Significant GHG emission savings can be made by maximising the conversion unit scale and pyrolysis efficiency, and minimising the feedstock ash content, as all these work to increase the chain efficiency, and reduce GHG emissions. The transport distances have more absolute impact on GHG emissions in Chain 10 than in Chains 8 and 9, because the lower chain efficiency acts as a multiplier, enhancing all the costs and GHG emissions, particularly for those components furthest upstream in the chain.

Only chains with very long transport distances or extremely high ash contents might struggle to be compliant with the post-2025 RO GHG emissions threshold (180 kgCO₂e/MWh_e), but otherwise the current base case is comfortably below the thresholds, suggesting headroom for different supply chain options/parameter values to be considered. This is because although the chain gross efficiency is low, the pyrolysis unit is mostly self-sufficient (provides its own drying etc.), and therefore has few materials or energy inputs, which keeps GHG emissions low.

5 Cross-over conditions

The analysis in Section 4 has been conducted for each chain in turn, but now the analysis starts explicitly comparing results between chains with the same conversion technology. This analysis is done by calculating the difference between the chains “with” pre-processing and the chain “without”³⁰ pre-processing (i.e. the groups are Chain 2 vs. 1, Chain 4 vs. 3, Chains 6 & 7 vs. 5, and Chains 9 & 10 vs. 8). There are therefore four chain group comparison exercises in this section of the report.

For most chain groups and base case values, as shown in Section 4.4, the chain without pre-processing is “better” (lower cost, emissions or higher efficiency) than the chain with pre-processing.

A “cross-over” is defined as occurring when by varying one input parameter, a chain with processing goes from being worse than the chain without pre-processing, to being better than the chain without pre-processing. Cross-overs can, and typically do, happen for the net chain LCOE, efficiency or GHG emissions metrics independently – i.e. varying one parameter might cause a cross-over to occur in the GHG emissions difference between two chains, but not a cross-over in the LCOE difference between the same two chains.

At some base case values, chains have already crossed-over, in which case the “with” processing chain is already better than the “without” pre-processing chain. An example would be the base case GHG emissions for Chain 10 already being considerably lower than the base case GHG emissions in Chain 8. However, it is still worth exploring when these chains might cross-over back over, e.g. the conditions under which Chain 10 has higher GHG emissions than Chain 8.

This cross-overs section examines and explains the situations where there are clear (or unclear) benefits of pre-processing, and the key trade-offs made – and hence where it is safe to draw conclusions.

5.1 Cross-over charts

The following cross-over charts show how the most relevant input parameters affect the difference in output metric values between chains that share the same conversion technology. The y-axis plots the difference in LCOE, difference in net efficiency or difference in GHG emissions between the two chains. The x-axis gives the absolute values of the input parameter being examined.

Graphically, a cross-over occurs when by varying the parameter on the x-axis, you go from above the $y=0$ line to below it (or vice versa). As the y-axis values are calculated as $Y_{\text{chain with pre-processing}} - Y_{\text{chain without pre-processing}}$, the with pre-processing chain is better in terms of LCOE or GHG emissions when the y-axis value is negative, and better in terms of net chain efficiency when the y-axis value is positive.

There are hundreds of input parameters that could have been plotted on the x-axis for each chart, but a selection process was used to calculate the differences between each pair of chains and take forward (for plotting) only those parameters that had the most favourable values, i.e. the parameters and metrics with cross-overs, or closest to achieving cross-overs.

³⁰ Note that all 10 chains technically include some form of pre-processing. However, in Chains 1, 3 and 5, this pre-processing is only screening, as these chains are assumed to be the simplest chains possible, and hence are described as being “without” significant pre-processing. For Chain 8, the pre-processing is used is pelleting (which is more significant), but given the scale of the conversion technology, it was assumed infeasible to use chip only supply chains, and hence including pelleting was the simplest supply chain possible.

The solid lines on each chart are plotted from the points already generated in MoDS for the spider diagrams. They show how the output metrics of the chains with pre-processing vary relative to the comparable chain without pre-processing when all of the parameters are set at their base values, except for the parameter shown on the x-axis. The large circles indicate the location of the base case value. On a few charts these circles are not included as the parameter on the x-axis had a different base value for the two chains being compared.

These charts also include scatter points due to the variation in the uncertain parameters. Deriving the uncertainty scatter clouds for each of the cross-over charts involved CMCL running the gPROMS model for each selected user-defined variable and each pair of chains 5,000 times, using MoDS. This was done whilst letting all the uncertain parameters vary uniformly between their minimum and maximum values, and whilst holding all of the user-defined variables (e.g. transport distance, storage time) at their base cases (except when the parameter on the x-axis is a user-defined variable, in which case it was also varied within its range).

All the cross-over charts below plot the difference (delta) between a pair of chains' results on the y-axis³¹. This pairing between chains is important as it removes variation due to any uncertain parameters that affect the results of both chains. The y-axis position of an individual scatter point in e.g. Figure 5.1 is calculated as $LCOE_{Chain\ 2} - LCOE_{Chain\ 1}$, and both these LCOE values are derived using the same values for the input uncertain parameters (e.g. the same Miscanthus ash content, the same underfeed boiler CAPEX multiplier). This requires the MoDS software to carefully pair up and simultaneously output e.g. Chain 1 and Chain 2 results sharing the same input values. The next scatter point is calculated from the next paired run of Chain 1 and Chain 2 sharing a new set of input values, and the following scatter point is calculated from another new shared set, and so on, in order to build up the scatter cloud of 5,000 scatter points. Each scatter point therefore corresponds to a different shared set of input values.

As well as the raw scatter point clouds, prediction intervals have been plotted. These dashed lines bound an area within which 95% of new model points are expected to fall³². These were produced by collecting the scatter points into groups based on their x-axis values and then using a non-parametric distribution to estimate the smallest range that satisfies the 95% requirement.

These prediction intervals (the region between the dashed lines) show how much the uncertainty parameters affect the likelihood of a cross-over when varying the x-axis parameter, and hence which cross-over results are very clear and robust to uncertainty (a very narrow prediction interval), and which are not clear and highly dependent on the uncertain parameters (a very wide prediction interval). This is also vital information to be able to include within the Venn diagrams in Section 5.2.

Exploring which uncertain parameters are most responsible for the width of the scatter clouds is out of scope, although some limited insights are already available from the spider and pie charts (as

³¹ A different type of cross-over chart could have been produced in TEABPP by plotting the absolute LCOE values for both chains on the same y-axis (e.g. show Chain 1 LCOE and Chain 2 LCOE charts overlaid, and leaving the reader to work out the delta by comparing the two datasets). However, this approach would have led to wider uncertainty clouds around each chain's base case line, and there would have been regions in which an important uncertain parameter has a relatively high value for one chain and a low value for the other, which would be misleading in drawing comparisons. For example, you would not want to compare how the absolute LCOEs for Chains 1 and 2 vary with blending split, when the Chain 1 results are all using high Miscanthus ash contents, and the Chain 2 results are all using low Miscanthus ash contents. This different type of cross-over chart was therefore not produced in TEABPP.

³² If the scatter points obeyed a normal distribution about the base case line, this 95% requirement would equate to 2 standard deviations in either direction from the base case line, however, many scatter point clouds do not follow a normal distribution and have some skew.

these identified the most sensitive parameters, covering both user-defined variables and uncertain parameters), and these are mentioned below (such as ash, moisture, costs, multipliers etc).

5.1.1 Chain 2 vs. Chain 1

As an explanation of how to read the first cross-over diagram (Figure 5.1), this plots the difference in LCOE between Chain 2 and Chain 1 (i.e. $\Delta = \text{LCOE}_{\text{Chain 2}} - \text{LCOE}_{\text{Chain 1}}$) on the y-axis. The x-axis shows the blending split, which can vary from a minimum of 0 (i.e. 100% Miscanthus) to a maximum of 1 (i.e. 100% Woody). The solid blue circle shows that at the base case blending split of 0.5, and with all other parameters also at their base case, the delta is £4/MWh_{th}, i.e. Chain 2 is more expensive. The solid blue line is the base case line, and shows that by increasing the blending split (more woody), the delta is very slightly higher, by decreasing the blending split (more Miscanthus), the delta becomes slightly closer to y=0. However, the base case line does not cross-over y=0, and so varying only the blending split parameter is unable to achieve a LCOE cross-over for Chain 2 vs. 1, and Chain 1 remains cheaper.

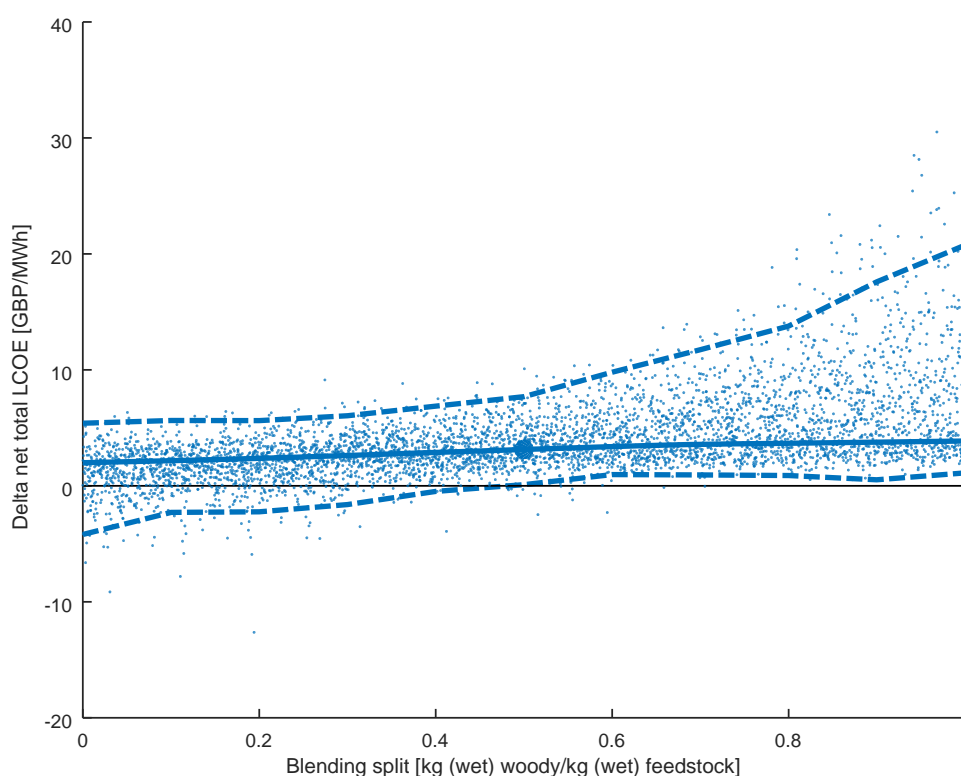

Figure 5.1: Chain 2-1 delta LCOE vs. Blending split cross-over chart

The very small blue dots show the 5,000 scatter point values, which together make up the uncertainty cloud. This cloud drifts downwards when moving left on the chart (increasing Miscanthus blending), with many individual points falling below y=0. This trend can also be seen by following the lower dashed blue line for the prediction interval, which at x=0 almost ends up as far below the y=0 line as the upper dash blue line does above y=0, i.e. there is very little to choose between the two chains. Interestingly, the uncertainty here is relatively small (only roughly $\pm£4/\text{MWh}_{\text{th}}$), because other important uncertain parameters like the underfeed stoker boiler capex multiplier are common to both chains, and therefore their influence has been removed when plotting the LCOE delta.

Moving to the right on the chart (increasing woody blending), the uncertainty cloud generally drifts upwards with a skew towards higher delta values (also seen by following the upper dashed blue line). There are almost no scatter points below $y=0$. This means that there are almost no Woody dominated runs with cross-overs, and Chain 1 is clearly preferred over Chain 2 to the right of the chart. So whilst the blending split parameter on its own is unable to achieve a LCOE cross-over, when varying other parameters as well the user is much more likely to find a LCOE cross-over for Chain 2 vs. 1 when they focus on Miscanthus rather than Woody feedstocks. This makes sense, as field washing has the greater benefit for Miscanthus, as Miscanthus has higher soil & stone contamination and higher halide content than Woody feedstocks.

The scatter cloud is much more tightly clustered at the left and centre of the chart, and much wider at the right. This means the results are more certain when using mainly Miscanthus, than when using mainly Woody feedstocks. This also makes sense, as the woody feedstocks have a high and wide range of moisture contents, and field washing adds more moisture, meaning many of the runs on the right of the chart have wet biomass arriving at the boiler, and hence lower efficiencies/high LCOE. This does not happen with Miscanthus, due to its dry starting condition and smaller range of moisture contents.

This LCOE delta vs. blending split chart is actually the only cross-over chart of interest that was worth plotting for any of the Chain 2 vs. 1 metrics, as the rest of the charts did not get close to crossing over. This is to be expected given the spider charts for Chains 2 and 1 are so similar. In contrast, the other chain groups below plot a number of different parameters for a number of different metrics, so this paucity of cross-over opportunities for Chain 2 vs. 1 is a result in itself – i.e. the opportunities for cross-overs are limited. This is confirmed by the Venn diagrams in Section 5.2.

5.1.2 Chain 4 vs. Chain 3

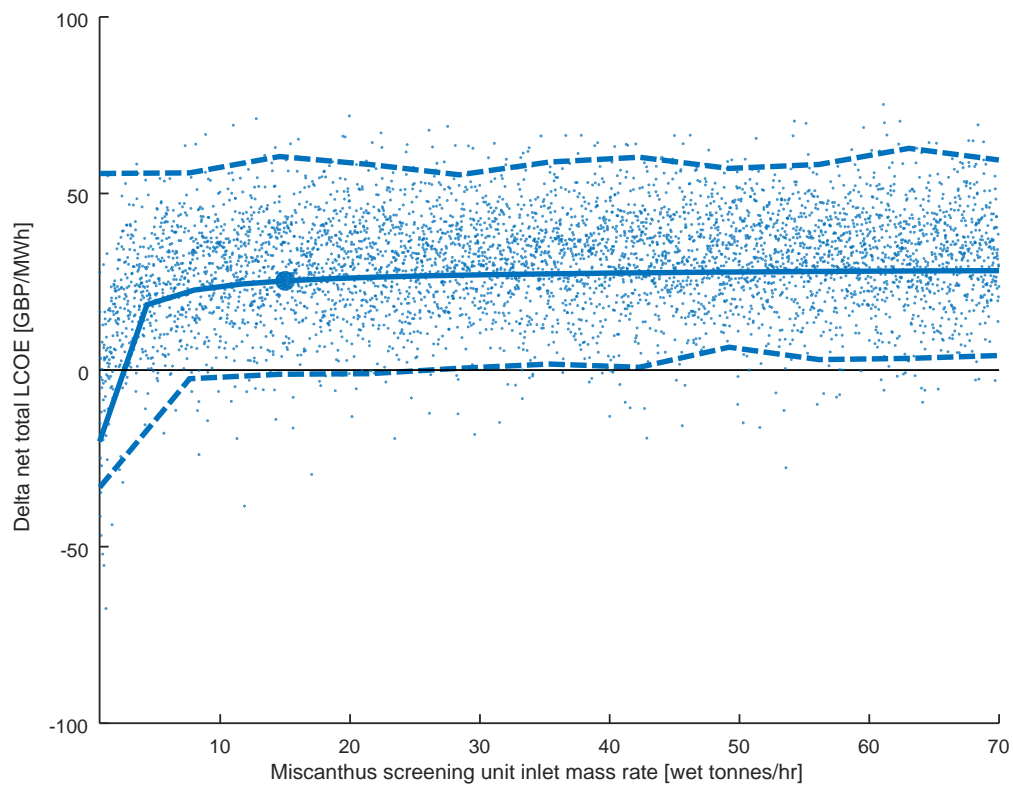

Figure 5.2: Chain 4-3 delta LCOE vs. Miscanthus screening unit inlet mass rate cross-over chart

For the Miscanthus screening unit inlet mass rate plotted in Figure 5.2, Chain 3 (screening) is definitively cheaper than Chain 4 (water washing + pelleting) at the base case, and at larger screening unit scales. This is demonstrated by the lower dashed line staying at or slightly above $y=0$, and the base case line staying flat, and well above $y=0$. It is only at the very smallest screening unit scales when Chain 3 becomes more expensive than Chain 4. However, this is to be expected, as Chain 4 does not have an onsite screening technology – i.e. this cross-over chart is effectively holding the Chain 4 LCOE constant, and only varying the Chain 3 LCOE. There is an almost identical LCOE cross-over chart with the Woody screening unit inlet mass rate plotted on the x-axis, which is not shown here for brevity.

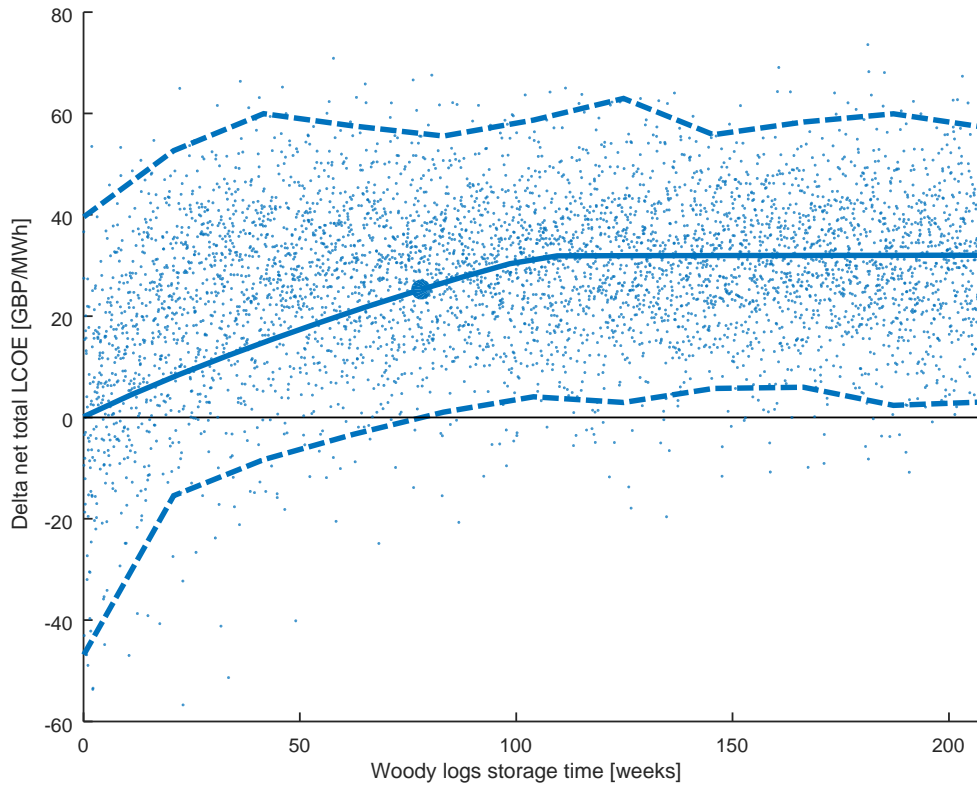

Figure 5.3: Chain 4-3 delta LCOE vs. woody log storage time cross-over chart

At the base case log storage time (78 weeks), and at higher log storage times, Chain 3 is clearly preferred to Chain 4, with the prediction interval also lying above $y=0$. However, setting the woody log storage time to zero causes Chains 3 and 4 to have the same LCOE when the other parameters are at their base case conditions (i.e. still with 50% Miscanthus). This suggests that if Chains 3 and 4 were using 100% woody feedstocks, this solid line would very likely cross-over at a modest number of weeks, and Chain 4 could be cheaper at zero storage time.

The scatter points are fairly evenly distributed around the base case line, with slightly more results above the base case line between 0-78 weeks. However, as shown by the wider spread of the dashed lines, the results at low storage times are slightly less certain.

Low log storage times mean that the chips in Chain 3 will be wet, resulting in paying for trucking water, and significantly lowering the BFB gasifier efficiency. Whereas in Chain 4, the extra natural drying step and then pelleting shield the BFB gasifier from any efficiency loss, and the pellets means minimal water is trucked around – so how wet the logs are after storage (based on log storage time) does not matter to Chain 4.

5.1.3 Chain 7 & Chain 6 vs. Chain 5

For chain groups where there are two chains “with” pre-processing being compared to one chain “without” pre-processing, the following cross-over charts contain two sets of data. In this subsection of the report, all the data in blue refers to the Chain 6 – Chain 5 delta, and all data in red refers to the Chain 7 – Chain 5 delta.

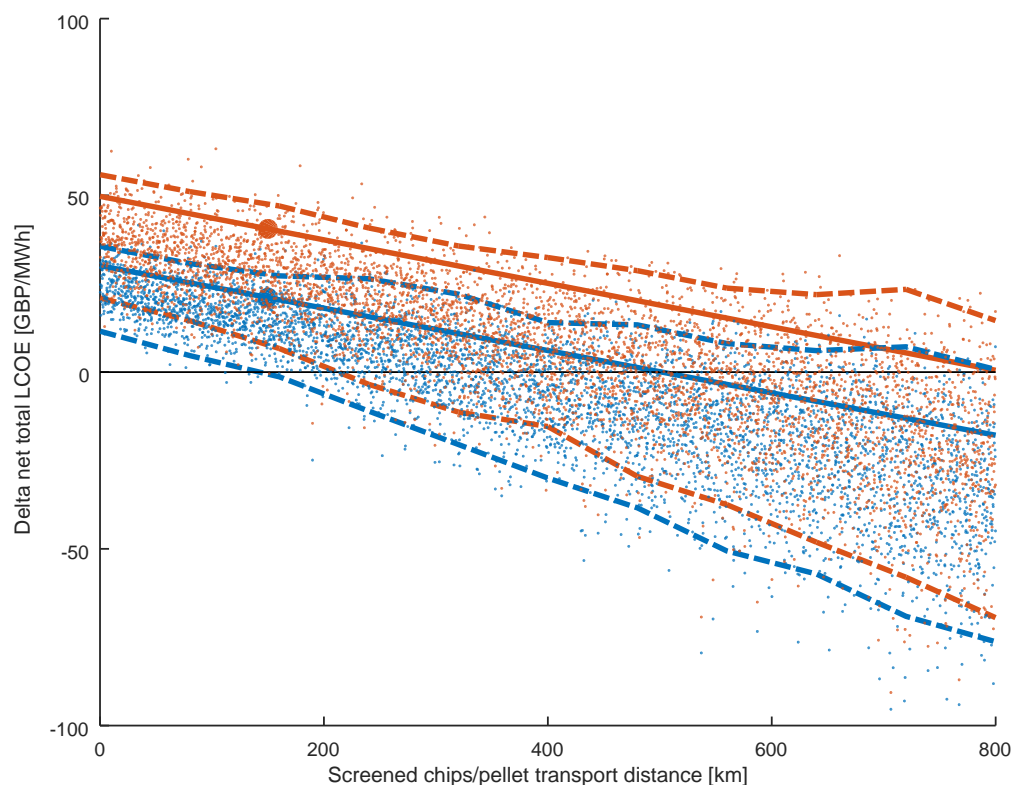

Figure 5.4: Chain 6-5 (blue) and Chain 7-5 (red) delta LCOE vs. screened chips/pellet transport distance cross-over chart

As shown on this chart, if the transport distance of the processed feedstock (screened chips or pellets) is high then pre-processing becomes more favourable. At the base case values (150km), Chain 5 remains cheaper than both Chains 6 and 7. However, above ~500km, the blue base case line for Chain 6 (pelleting) becomes cheaper than Chain 5 (chips). The blue uncertainty cloud is relatively tight at low transport distances, but becomes increasingly wide as transport distances increase. This is because as distances increase, the other uncertainties related to the transport step (such as fuel consumption, driver wages etc.) are accentuated. It is also noticeable that the majority of blue scatter points lie below the blue base case line, i.e. favouring Chain 6 instead of Chain 5, which is likely to be due to particularly low chip densities skewing Chain 5 transport costs upwards. Following the prediction intervals, at the maximum 800km, over 95% of the results lie below $y=0$, i.e. this chart just shows a full cross-over with clear daylight between Chain 6 and 5.

For Chain 7 – Chain 5 shown in red, this is further away from achieving a cross-over, due to the added costs of chemical washing. The base case line just reaches $y=0$ at the maximum 800km, but this is not a clear cross-over, as the prediction interval lies above and below $y=0$. The red prediction interval is wider than the blue interval, which is due to the additional chemical washing parameters and chain complexity. The red base case line is also particularly heavily skewed towards the upper dashed line, i.e. the large majority of red scatter points lie below the base case line, suggesting that many combinations of the uncertain parameters will favour Chain 7 over Chain 5, particularly at the largest transport distances.

Exactly the same messages can be read from this LCOE cross-over chart for transport distance as can be extracted from the net chain efficiency cross-over chart for transport distance, so this second chart is not shown. The two charts look identical, having very similar cross-over points and clouds,

except that the net chain efficiency chart is inverted (i.e. the efficiency deltas start below $y=0$, and lines then rise as transport distance increase, because Chains 6 and 7 use significantly less diesel per MWh than Chain 5).

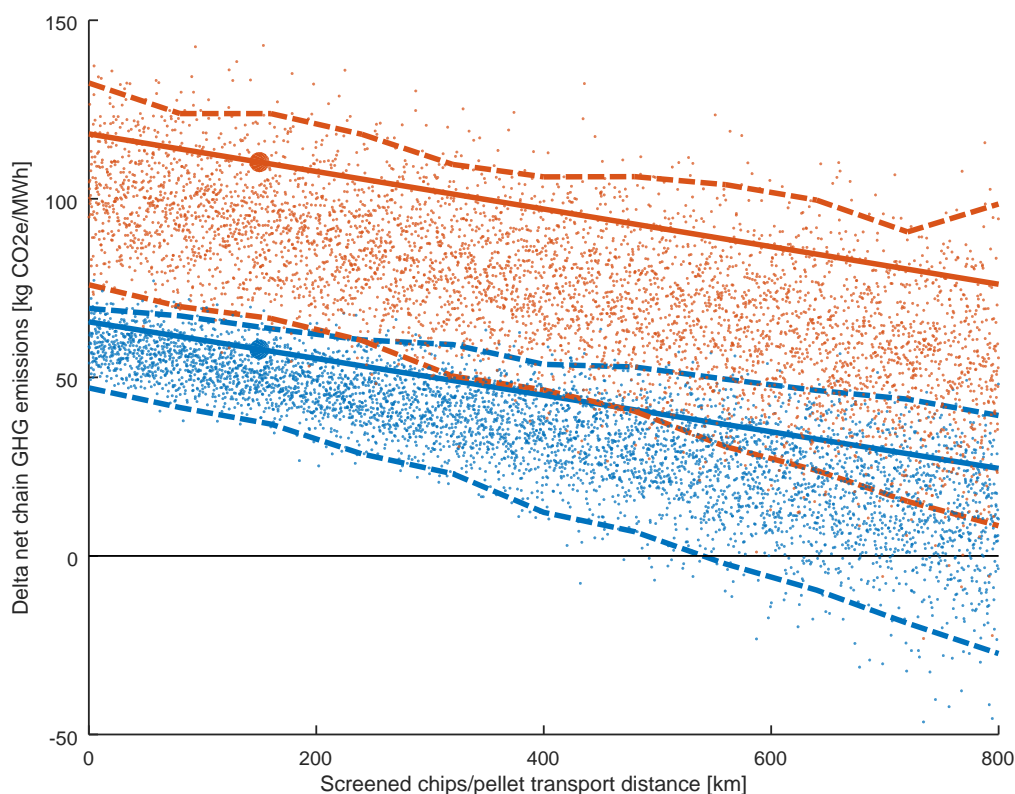

Figure 5.5: Chain 6-5 (blue) and Chain 7-5 (red) delta GHG emissions vs. screened chips/pellet transport distance cross-over chart

Taking the same parameter (screened chips/pellet transport distance), but plotting the delta in GHG emissions gives a slightly different picture to the LCOE and efficiency deltas. Chain 5 is strongly and clearly favoured in terms of GHG emissions over Chain 7 at all distances, and over Chain 6 at all distances <530km (when the lower dashed line reaches $y=0$). Neither blue or red base case lines are able to achieve a cross-over. This is because the GHG emissions factors associated with the energy and materials inputs to pelleting and chemical washing are significant, in comparison to the very simple screening used in Chain 5.

However, there are similarities to the earlier LCOE cross-over chart, in that the scatter points are typically distributed below the base case lines, and the uncertainty increases with increasing transport distances.

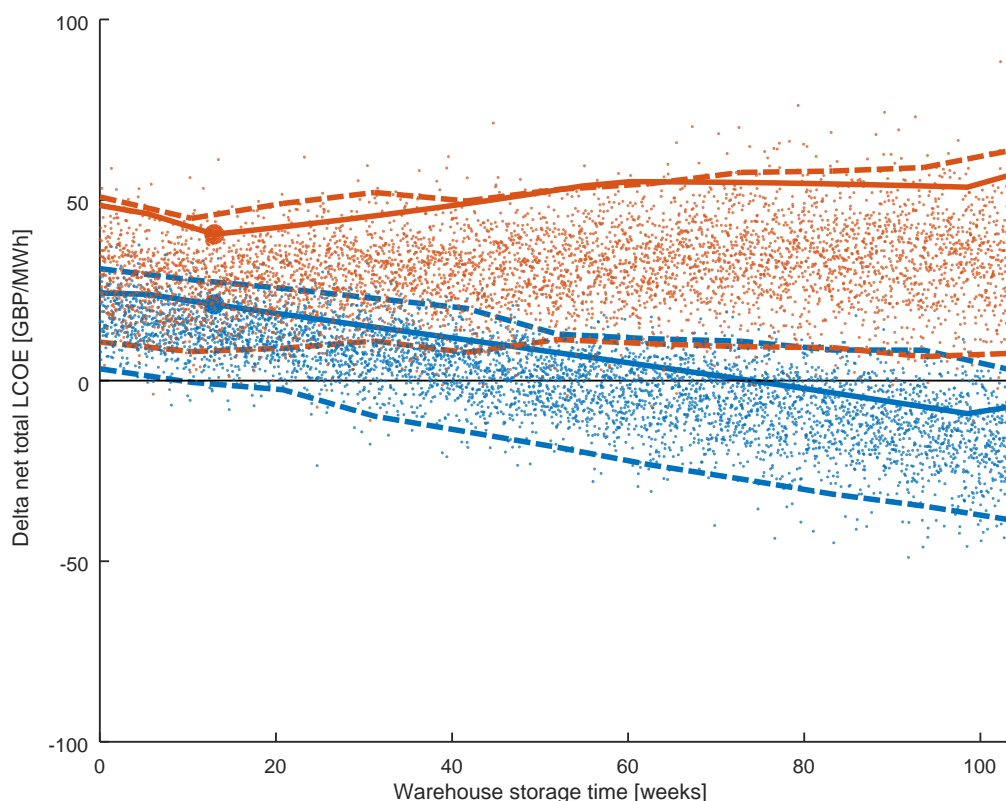

Figure 5.6: Chain 6-5 (blue) and Chain 7-5 (red) delta LCOE vs. warehouse storage time cross-over chart

As a reminder, warehouses are used in Chains 5 (directly after screening on the same site) and Chain 7 (directly after chemical washing and before pelleting, all on the same site), as well as in Chain 4 (directly after water washing and before pelleting, all on the same site). Chain 6 does not use a warehouse, and only uses a silo after pelleting.

The circles show that Chain 5 is cheaper than Chains 6 or 7 at the base case. For the blue data set (Chain 6 – Chain 5), the base case line crosses-over at ~75 weeks, when Chain 5 becomes more expensive than Chain 6. This makes sense, as the capex for warehouse storage and chip degradation increase with storage time, whereas Chain 6 costs have not changed (silo storage time has not been changed in this chart – if it were also increased at the same time as the warehouse storage time, then these delta changes would be reduced). The blue prediction intervals are relatively tight, and the blue scatter cloud is generally lying below the base case line, i.e. favouring Chain 6.

The red base case line for Chain 7 – Chain 5 shows several different gradients, due to the differences in the drying and degradation rates and hence optimal storage times between the two chains. The base case storage time happens to already minimise the LCOE delta, with shorter storage time giving wet biomass to pelleting in Chain 7, and longer storage times degrading quicker than in Chain 5. The red scatter cloud is almost entirely lying below the red base case line (so much so, that the base case line overlaps with the upper prediction interval). However, the lower prediction interval is always above $y=0$, so Chain 7 is clearly more expensive than Chain 5, even with uncertainties.

Exactly the same messages can be read from this LCOE cross-over chart for warehouse storage time as can be extracted from the net chain efficiency cross-over chart for warehouse storage time, so this further chart is not shown. The two charts look very similar, having very similar cross-over points and clouds, except that the net chain efficiency chart is inverted (i.e. the efficiency deltas start below

y=0). The base case lines follow a similar pattern, but with somewhat steeper gradients, as the storage time first impacts on drying and degradation and hence efficiencies, and only then LCOE.

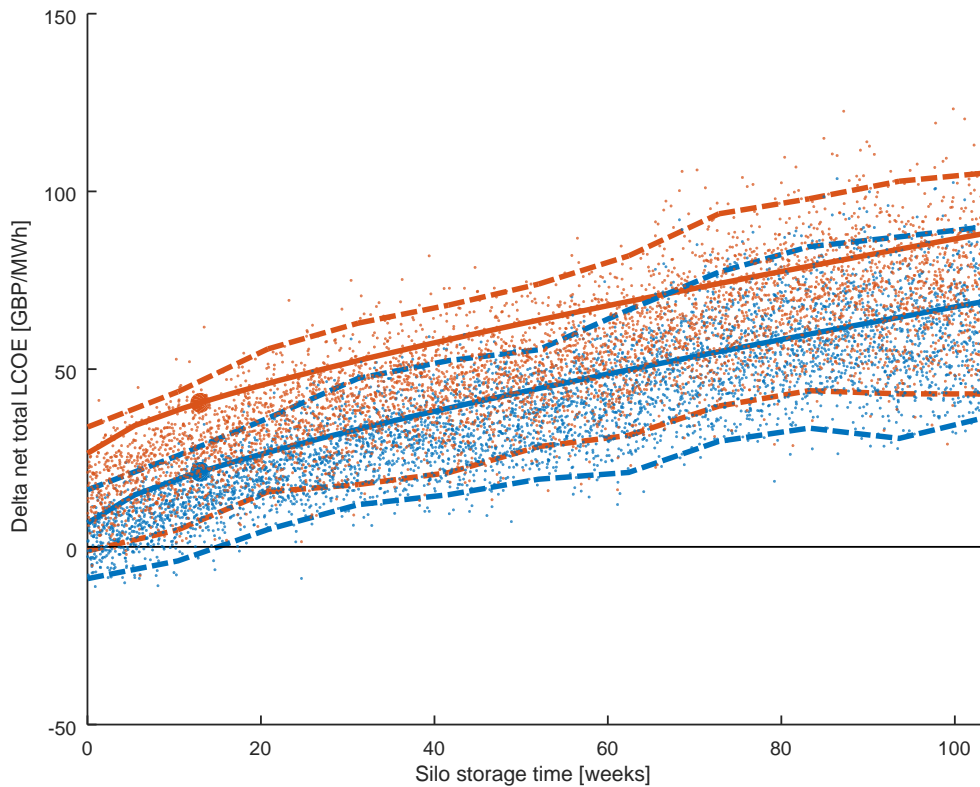

Figure 5.7: Chain 6-5 (blue) and Chain 7-5 (red) delta LCOE vs. silo storage time cross-over chart

Only Chains 6 and 7 use a silo after pelleting – Chain 5 does not use a silo. In the chart above, the costs for Chain 5 are therefore fixed, and longer silo storage times only increase the costs of both Chains 6 and 7. Reducing the silo storage times below the base case does significantly reduce the gaps to Chain 5, but does not achieve any cross-overs. At 0 weeks, small silos are no longer built, and so there is a small step down in Chain 6 and 7 costs as these fixed costs are removed (in addition to removal of just the incremental costs).

The uncertainty clouds get slightly wider with increased storage time as this accentuates the impact of other uncertain storage parameters (e.g. power usage, degradation rates). Very few points lie below y=0, and these are almost exclusively blue points.

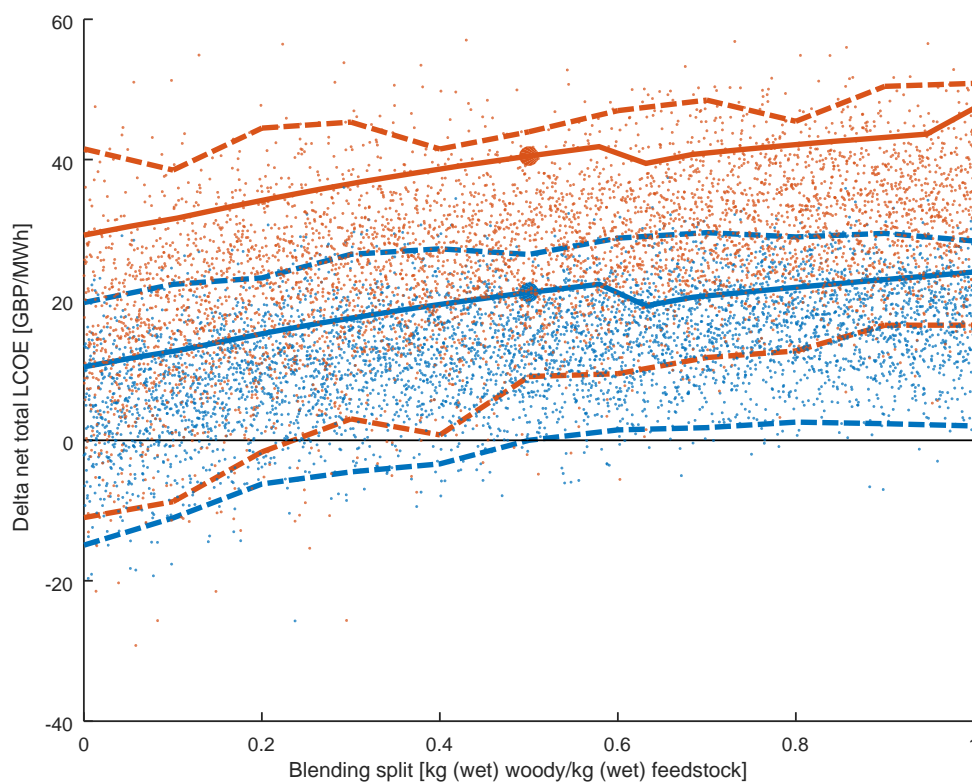

Figure 5.8: Chain 6-5 (blue) and Chain 7-5 (red) delta LCOE vs. blending split cross-over chart

The (generally) positive gradients of the base case lines shows that using a high proportion of woody feedstocks leads to both Chains 7 and 6 becoming even more expensive than Chain 5, whereas using a high proportion of Miscanthus leads to a reduction in the gap to Chain 5 – but still no cross-overs (without changing other user defined inputs). The kinks³³ in the base case lines are because below 40% Miscanthus (blending split >60%), a binder is no longer needed in pelleting, which results in small cost savings for Chains 7 and 6.

Again, both red and blue scatter clouds are generally found to lie under their respective base case line, favouring the chains with pre-processing. Chain 6 is closer to crossing-over than Chain 7, with slightly more blue scatter points lying under $y=0$ than red scatter points.

5.1.4 Chain 10 & Chain 9 vs. Chain 8

In this sub-section of the report, all the data in blue refers to the Chain 9 – Chain 8 delta, and all data in red refers to the Chain 10 – Chain 8 delta.

Due to the extremely high LCOE and GHG emissions values for some of the scatter point runs in this section (particularly for Chain 10 with combinations of high ash, high Miscanthus blends and low efficiencies), the y-axis range has been set so that the variation in the base case lines are still distinguishable. In several cases this means the red dashed line will be well above the top of the y-axis, so it is not visible on the chart.

³³ Note that these kinks are supposed to be threshold discontinuities, rather than slopes, but these base case lines are only plotted using 20 points, and hence the best fit line joins these 20 points together. A larger number of points would have taken longer to run.

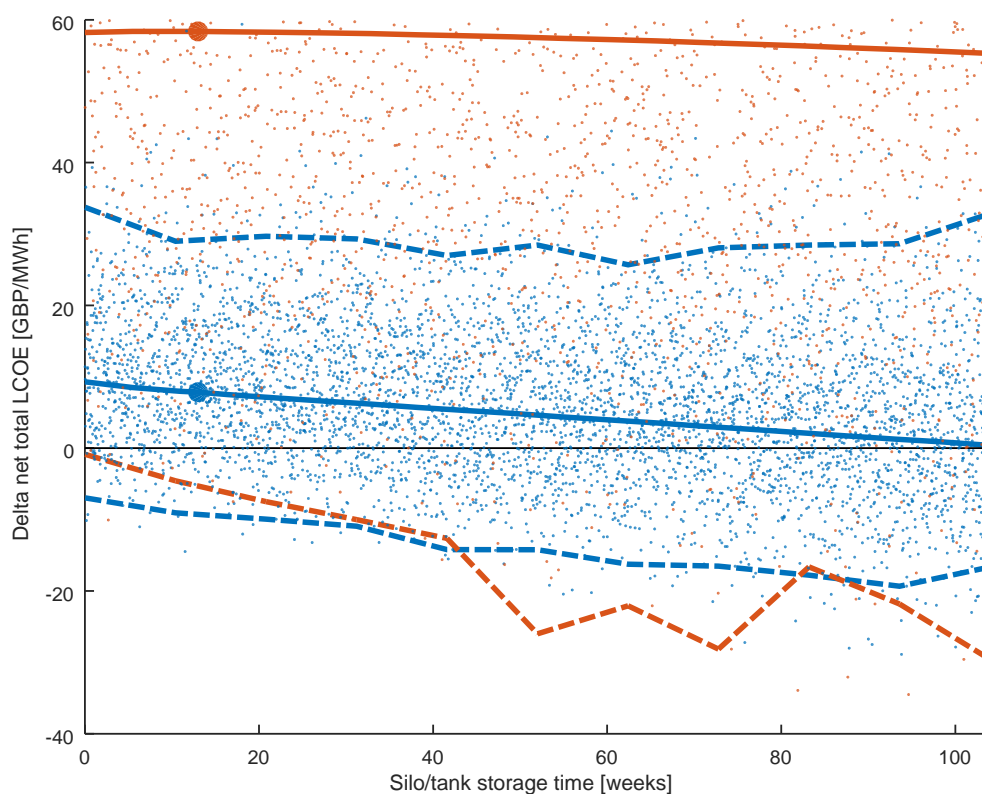

Figure 5.9: Chain 9-8 (blue) and Chain 10-8 (red) delta LCOE vs. silo/tank storage time cross-over chart

For LCOE vs. silo/tank storage time, both base case circles lie above $y=0$, so Chain 8 is cheapest at this point. However, with increasing storage time, Chain 8 costs rise faster than Chain 9 costs, so that by 104 weeks (2 years), the LCOEs of these chains are the same (blue base case line just reaches $y=0$). This occurs because the torrefied pellets have a higher LHV than standard pellets, and so are cheaper to store, which makes a considerable difference if the storage requirement is very large. The uncertainty cloud around the results are relatively large, with no strong skew (the blue base case line lies in the middle of the cloud), and limited widening over time.

Looking at the red dataset, the uncertainty around the results are an order of magnitude higher than the blue dataset (particularly if looking at the uncertainty points not plotted above the chart range), due to the impact of ash, blending and efficiency uncertainties on the pyrolysis oil output³⁴. Varying the silo and tank storage time³⁵ has little impact on the LCOE delta, as the costs of tank storage are only slightly cheaper than silo storage. The red base case line does not get close to crossing-over.

³⁴ Although the scatter points are still calculated and plotted, note that the gPROMS model raises many flags for Chain 10, because the pyrolysis data and relationships were only specified for ash contents of up to 4%, whereas Miscanthus with maximum soil & stone contamination levels can exceed 9% ash at its maximum level. The very highest LCOE and GHG emissions values (well off the top of these charts) are therefore unlikely to be seen in practice, as the pyrolysis plant (as specified) would not accept these ash levels.

³⁵ But note that there are technical challenges for long-term storage of pyrolysis oil that are yet to be fully resolved, so there are questions whether 2 years of bio-oil tank is feasible.

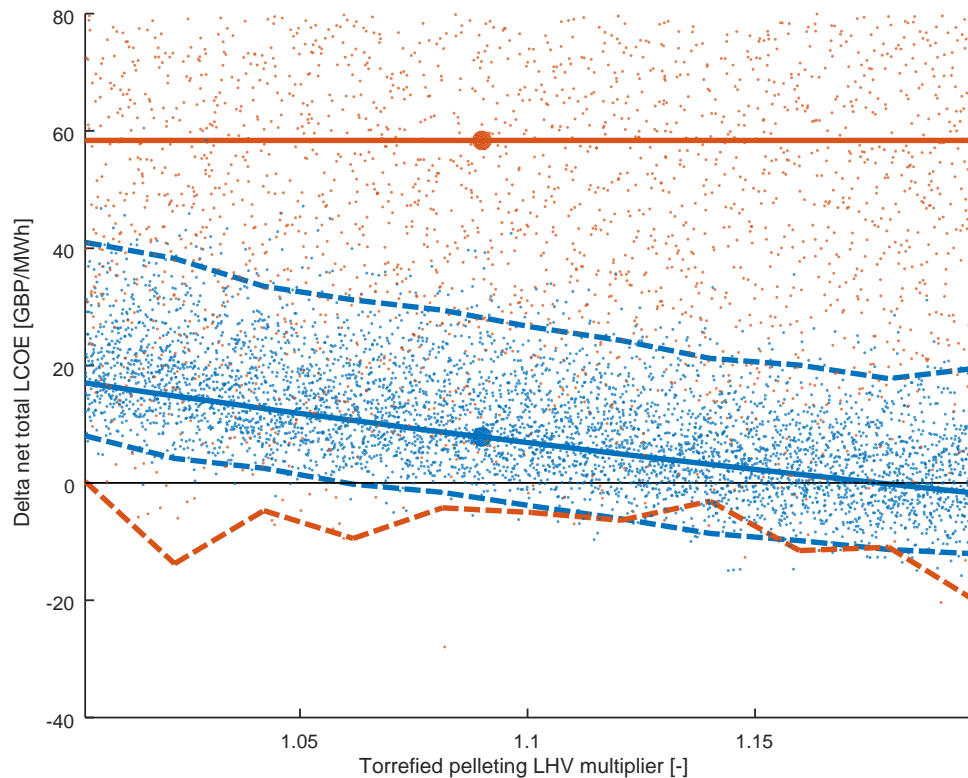

Figure 5.10: Chain 9-8 (blue) and Chain 10-8 (red) delta LCOE vs. torrefied pelleting LHV multiplier cross-over chart

The torrefied pelleting LHV multiplier determines the LHV of the output torrefied pellets from pre-processing. This only impacts Chain 9, which means there is no change in the LCOE of Chains 8 or 10, which can be seen by the flat red base case line, and the (relatively) flat³⁶ prediction interval dashed line. In other words, the red dataset provides no information.

The torrefied pellets do not have a fixed LHV, due to the varying LHVs of the input feedstocks, but for context, a typical output LHV using the base case multiplier of 1.09 would be 19-20 GJ/odt. Increasing the multiplier to its maximum value of 1.20 would give output LHVs of around 21-22 GJ/odt.

As shown in the chart above, if the torrefaction LHV multiplier is low, i.e. the output pellets have a very similar LHV to the input biomass, then Chain 9 is clearly (even with uncertainties) more expensive than Chain 8 (only pelleting). However, following the blue base case line downwards shows that above about 1.18, Chain 9 becomes cheaper than Chain 8, due to the silo and transport step cost reductions that higher LHV pellets enable. Efforts to improve the torrefaction output LHV are therefore important to its success in the chains analysed. The uncertainty cloud is relatively slim, and not skewed, but the cross-over is not strong enough to provide clear daylight between Chain 9 and 8 (the upper blue dashed line is still well above $y=0$).

³⁶ The jumps and movement in the red dashed line are due to random scatter point clustering. If the model were run 500,000 times instead of 5,000, this line would be perfectly flat. In general, the wider the uncertainty cloud on any cross-over chart, typically the more movement there is in these dashed lines.

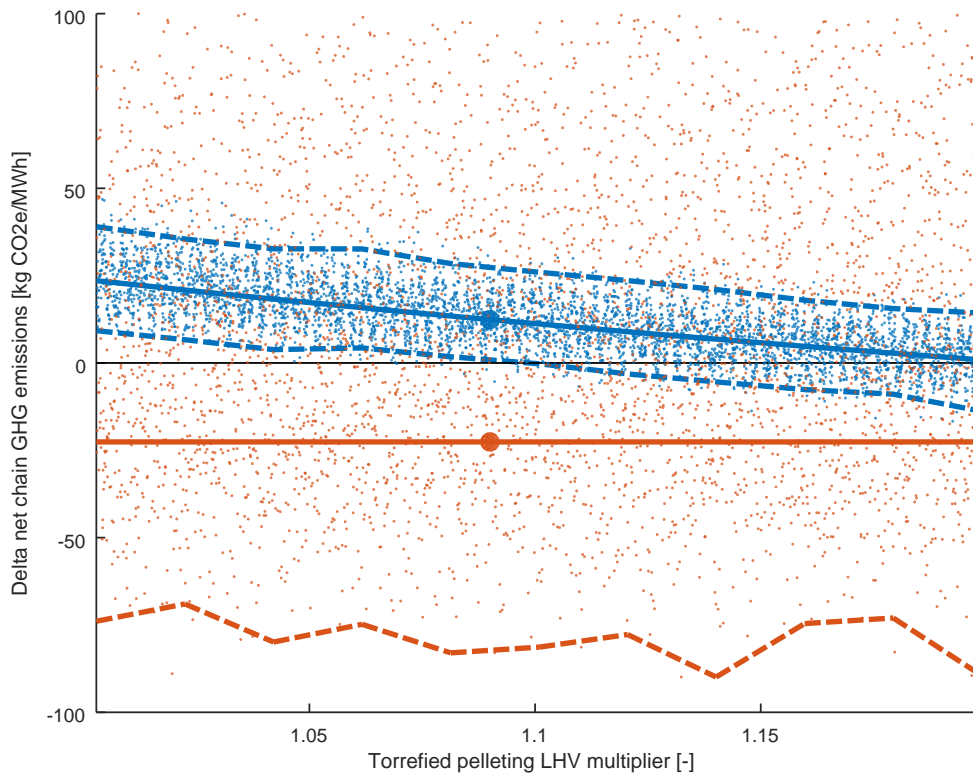

Figure 5.11: Chain 9-8 (blue) and Chain 10-8 (red) delta GHG emissions vs. torrefied pelleting LHV multiplier cross-over chart

A similar picture can be seen for the GHG emissions delta when varying the torrefied pelleting LHV multiplier. Again, Chain 10-8 provides no information, so the red dataset can be ignored. If the torrefaction LHV multiplier is low, then Chain 9 clearly has (even with uncertainties) higher GHG emissions than Chain 8 (only pelleting). However, following the blue base case line downwards shows that at the maximum value of 1.20, Chain 9 could have the same GHG emissions as Chain 8 (although with some modest uncertainties still present), due mainly to the diesel savings in transport that higher LHV pellets enable. Efforts to improve the torrefaction output LHV are therefore also important to minimise the additional GHG emissions from adding torrefaction – and not just a cost driver.

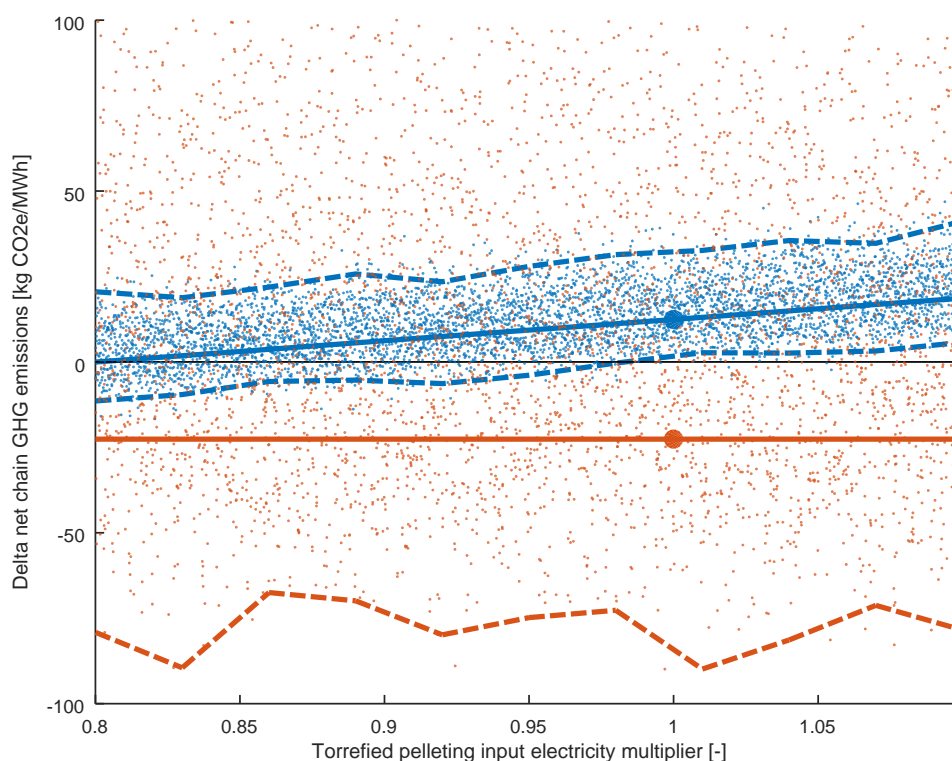

Figure 5.12: Chain 9-8 (blue) and Chain 10-8 (red) delta GHG emissions vs. torrefied pelleting input electricity multiplier cross-over chart

Another important factor in the GHG emissions of Chain 9 is the electricity consumption in torrefaction + pelleting. In the chart above, Chain 10-8 provides no information, so the red dataset can be ignored.

If the torrefied pelleting input electricity multiplier is at or above the base case of 1.00, then Chain 9 clearly has (even with uncertainties) higher GHG emissions than Chain 8 (only pelleting). However, following the blue base case line downwards shows that at the minimum value of 0.80 (i.e. 20% lower power use than in the base case), Chain 9 could have the same GHG emissions as Chain 8 (although with some modest uncertainties still present). Modest efforts to minimise the power use required across the various plant steps (drying, torrefaction, milling and pelleting) are therefore important to minimise the additional GHG emissions from adding torrefaction.

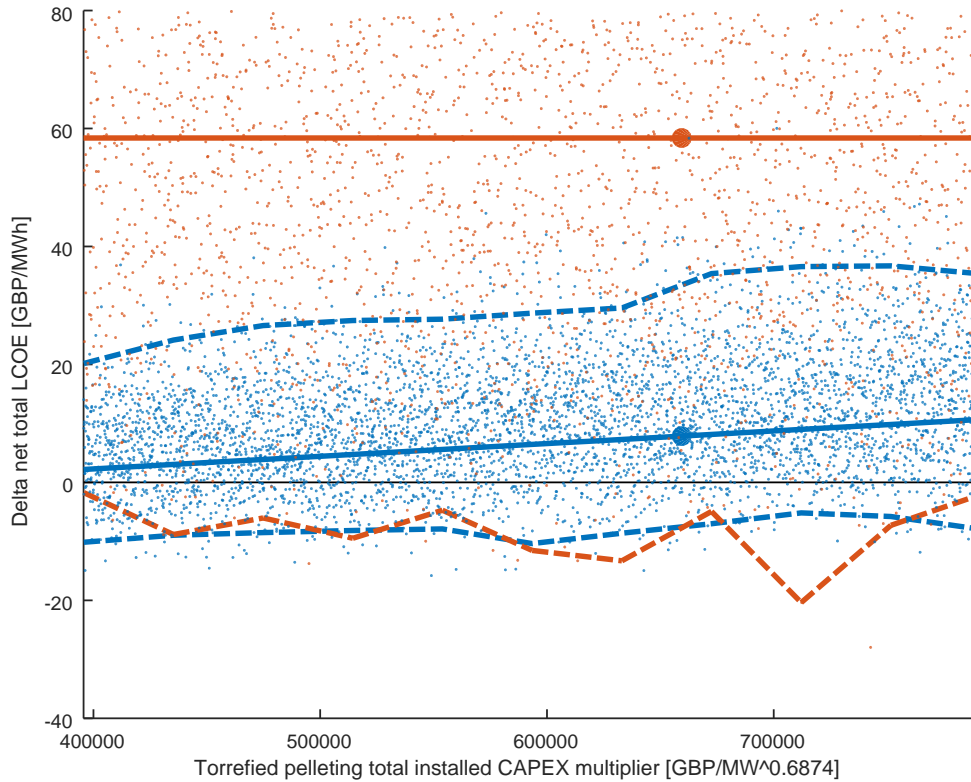

Figure 5.13: Chain 9-8 (blue) and Chain 10-8 (red) delta LCOE vs. torrefied pelleting total installed CAPEX multiplier cross-over chart

The cross-over chart above is varying the torrefaction + pelleting CAPEX. Again, Chain 10-8 provides no information, so the red dataset can be ignored. There is only an increase or decrease in Chain 9 LCOE as the parameter increase or decreases, as can be seen by the blue base case line. The spread in the uncertainty cloud is relatively small (observe the y-axis scale), and with no particularly strong skew above or below the blue base case line.

At the minimum torrefied pelleting CAPEX, Chain 9 still is not cheaper than Chain 8, but there are a large number of blue scatter plots below $y=0$, and the chains are close to crossing over. The torrefaction + pelleting CAPEX will therefore be important to target as one of the key parameter to reducing Chain 9 LCOE.

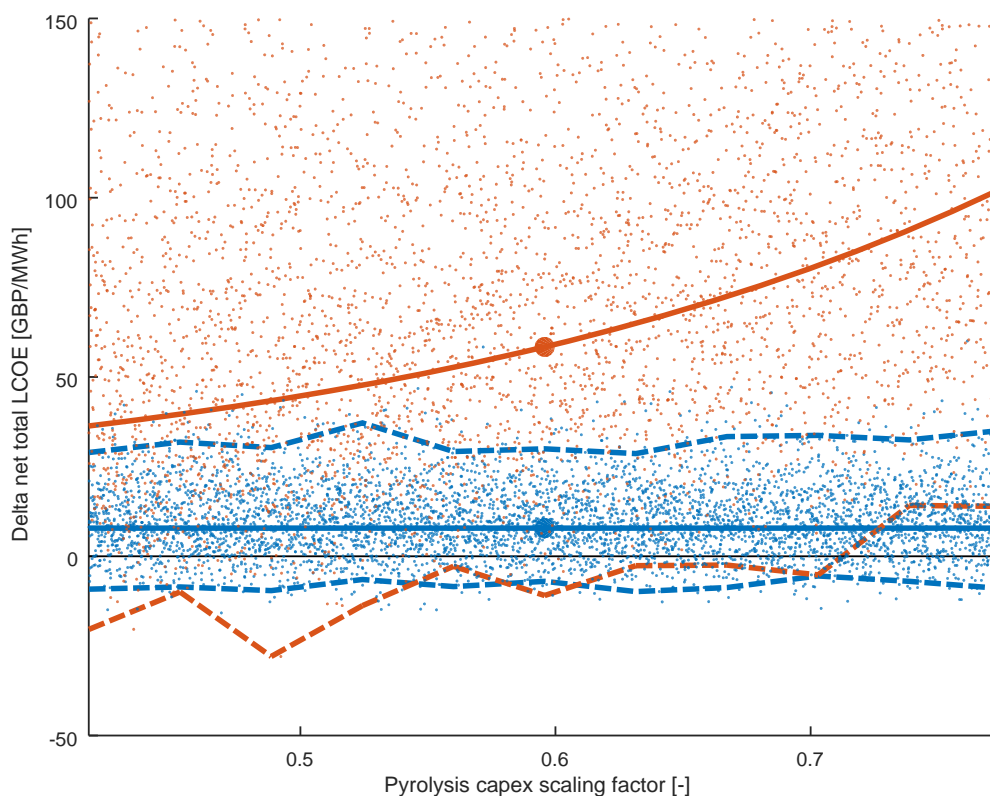

Figure 5.14: Chain 9-8 (blue) and Chain 10-8 (red) delta LCOE vs. pyrolysis CAPEX scaling factor cross-over chart

Similar to the torrefied pelleting CAPEX having a large effect on the LCOE of Chain 9, the pyrolysis CAPEX scaling factor (i.e. effectively the pyrolysis plant CAPEX at a new given scale) has a large impact on the LCOE of Chain 10. In this chart, the blue dataset is completely flat/can be ignored, as there is no impact on the LCOE of Chains 9 or 8.

The red base case line shows that if the scaling factor³⁷ were as low as ~ 0.4 (i.e. the pyrolysis base case CAPEX were reduced), then the Chain 10 LCOE could fall, but not enough to achieve a cross-over. The red uncertainty cloud remains very large, but as expected, a few more points are found below $y=0$ when the pyrolysis CAPEX is cheaper.

³⁷ Scaling factor in this context is used to derive the base case CAPEX = CAPEX multiplier * (base case MW input) ^ scaling factor. Therefore a low scaling factor equates to a low CAPEX value, and a high scaling factor equates to a high CAPEX value. Scaling factors are only an engineering approximation of how the capex of different technologies change when changing scales.

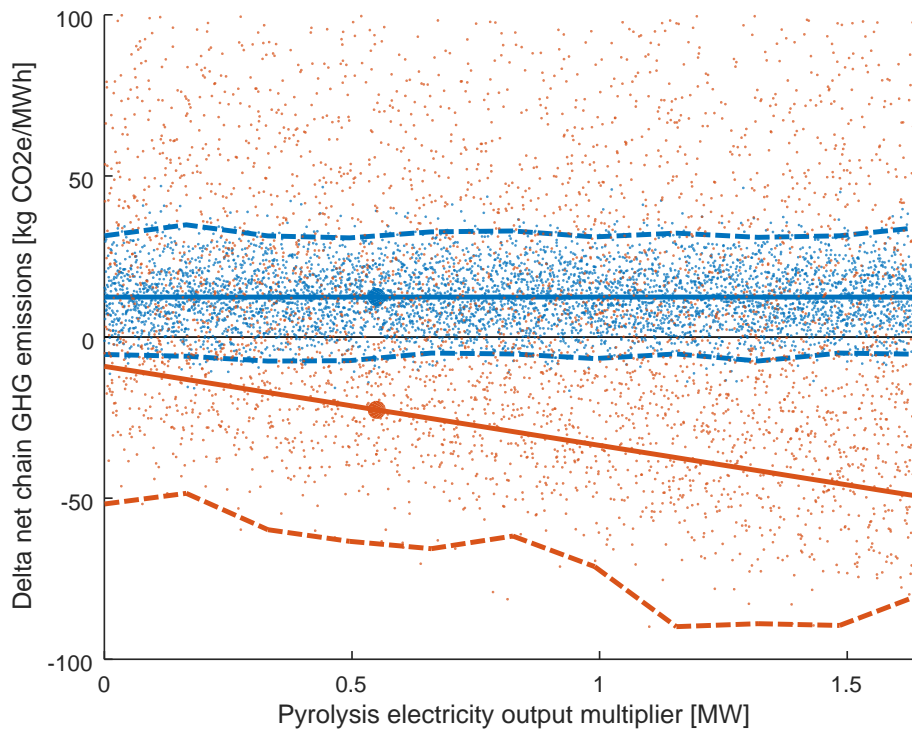

Figure 5.15: Chain 9-8 (blue) and Chain 10-8 (red) delta GHG emissions vs. pyrolysis electricity output multiplier cross-over chart

The pyrolysis electricity output multiplier determines how much power (in MW_e) each pyrolysis unit generates for export, alongside the main bio-oil output. This electricity is a co-product output to Chain 10, and is credited with revenues and a GHG emissions credit (based on the current UK grid GHG intensity). This parameter has no impact on Chains 8 and 9 (hence the lack of information in the blue dataset).

The chart above shows Chain 10 has lower GHG emissions than Chain 8 at the base case circle. This is mainly due to the self-sufficiency of the pyrolysis unit compared to pelleting. This GHG emissions benefit increases if the electricity exports increase. However, if the pyrolysis plant generates zero electricity for export, then the GHG emissions of Chain 10 increase, and almost become as high as Chain 8. Maintaining a fully optimised pyrolysis plant, and ensuring that any pyrolysis gases and char are converted to useful heat (for biomass drying, and the excess turned into power for plant operations and export) will be important to maintaining the GHG benefits of Chain 10.

The red scatter cloud is still large, and heavily skewed upwards above the base case line – i.e. many runs result in Chain 10 having much higher GHG emissions than Chain 8, mainly due to the combination of high ash, high Miscanthus and low efficiency parameters.

A very similar GHG emissions cross-over over chart could be plotted for the pyrolysis efficiency multiplier on the x-axis (but is not for brevity). This would have a very similar base case line and uncertainty cloud (and no impact on Chain 9 vs. 8). If the pyrolysis efficiency drops by 20%, the GHG emissions of Chains 10 and 8 will be the same, but if the pyrolysis efficiency increases by 40%, the GHG emissions of Chain 10 will end up ~50 kgCO₂e/MWh_e lower than Chain 8.

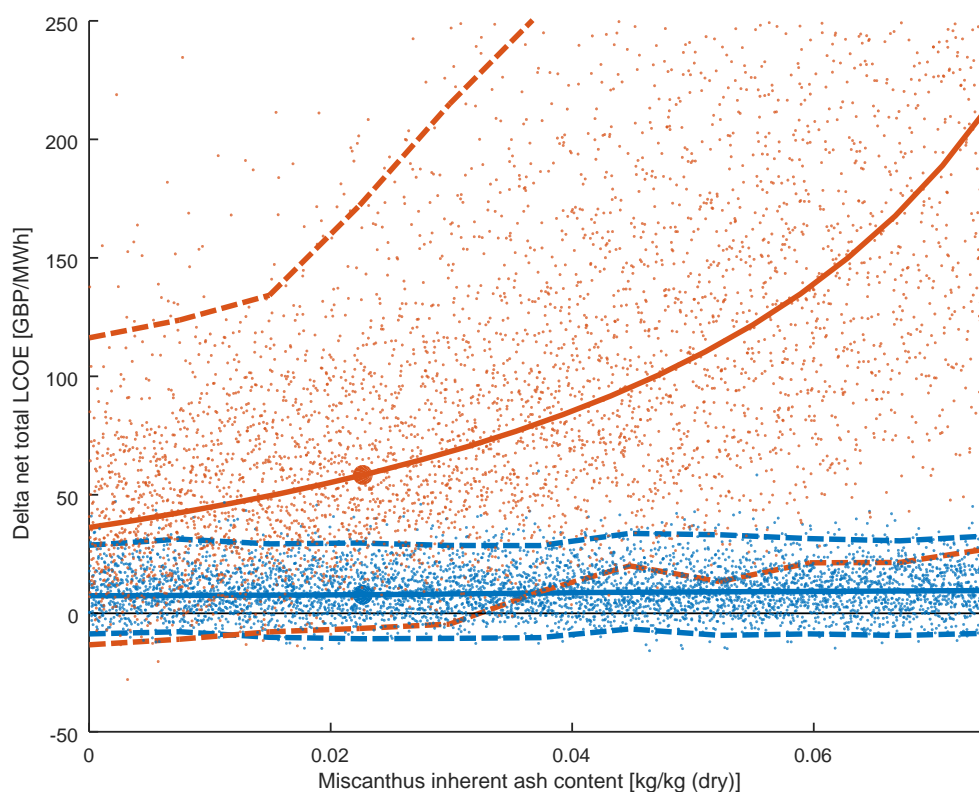

Figure 5.16: Chain 9-8 (blue) and Chain 10-8 (red) delta LCOE vs. Miscanthus inherent ash content cross-over chart

As discussed at the start of this subsection, the ash content of the feedstocks is the biggest driving factor of the uncertainties for Chain 10. Here we examine the Miscanthus ash content in more detail.

This chart shows that the Miscanthus ash content has relatively little impact on Chain 9 vs. 8, as the blue base case line is almost flat, with only a very slight increase towards further favouring Chain 8 as the ash content increases (i.e. a very small positive gradient). This is expected, as the torrefaction processes increases the ash content by $\sim 20\%$ on a dry basis (by removing the volatiles), and so higher starting ash contents will mean torrefaction slightly accentuates the impact of ash in the EF gasifier. The blue uncertainty cloud is relatively slim, with a number of points below $y=0$.

However, ash content has a much more dramatic impact on the red dataset, due to the impact on Chain 10. Increasing the Miscanthus inherent ash content above the 2.3% base case value leads to a dramatic drop in pyrolysis oil production, and rise in Chain 10 LCOE. Taking a zero value for the inherent ash content of the Miscanthus (and bearing in mind that soil & stone contamination and the woody inherent ash contents are all non-zero) does reduce the LCOE gap, but not enough for a cross-over. The uncertainty cloud is large, and grows significantly as ash content increases, confirming the importance of this uncertain parameter on the prediction intervals in other charts. Very few red scatter points lie below $y=0$. Looking at ways to remove ash before pyrolysis, or R&D to improve the tolerance of pyrolysis to ash, will be important to lowering Chain 10 LCOE.

If Woody inherent ash content were plotted on the x-axis instead, the resulting LCOE cross-over chart would be very similar (so not included here), with a similar red curve, lack of cross-overs and wide uncertainty clouds. However, the smaller range of woody ash contents compared to the Miscanthus ash content range means the x-axis maximum does not go as far right in this second chart, and so the LCOE delta does not go as high (the chart appears to be slightly zoomed in).

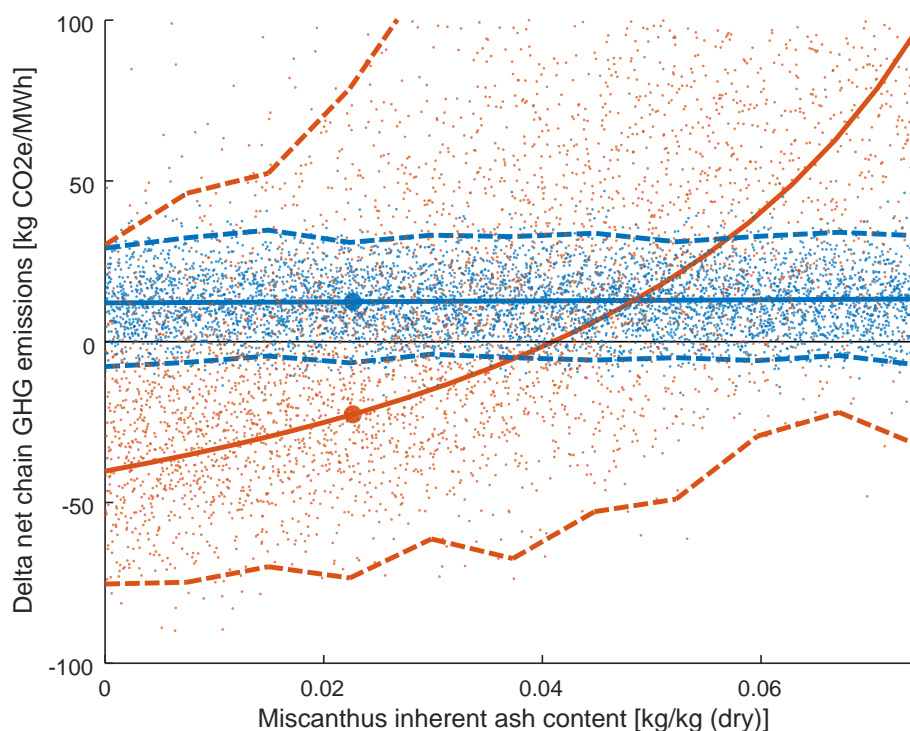

Figure 5.17: Chain 9-8 (blue) and Chain 10-8 (red) delta GHG emissions vs. Miscanthus inherent ash content cross-over chart

This chart plots the same Miscanthus inherent ash content, but comparing GHG emissions deltas. There is little change in the blue deltas, with Chain 9 staying slightly above Chain 8, and only a few results below $y=0$. At very low ash contents, the GHG emissions for Chain 10 are generally below Chain 8 (with only a limited number of scatter points above $y=0$), but above $\sim 4\%$ inherent ash content, Chain 10 efficiencies drop far enough that the GHG emissions increase above those of Chain 8. As expected, the uncertainty clouds are wide.

The chart for Woody inherent ash content is almost identical (so not included here), with the red base case line crossing over at $\sim 4\%$ inherent ash content. As well as the zoomed in appearance, the one difference is that the red upper dashed line is higher, denoting greater uncertainty.

Due to the blending, the uncertainty cloud width will be larger than if only one feedstock were used – fewer parameters mean less uncertainty, and less dilution of feedstock characteristics. If say 100% Miscanthus were used, and the above the chart were re-plotted, it is possible that at low ash contents, Chain 10 would be clearly better than Chain 8 (i.e. the upper prediction interval dashed line could fall below $y=0$). The red curve would likely also be steeper, due to removing the dilution of the (fixed) woody ash content base case value.

5.2 Venn diagrams

Using the cross-over charts generated in section 5.1 for each pair of chains sharing a conversion technology (e.g. Chain 2 vs. 1, or Chain 7 vs. 5), CMCL have selected and manually translated those charts that show clear or unclear cross-overs into a single Venn diagram.

These Venn diagrams have a green left-hand region summarising the key parameter ranges where the chain “without” pre-processing is clearly better (even with uncertainties), a purple right-hand region summarising where the chain “with” pre-processing is clearly better (even with uncertainties), and a grey central overlapping region within which parameter ranges there is no clear preference between the chains (due to the uncertainties). The grey central region is, however, subdivided into two columns showing the regions within which the base case line is above or below zero (i.e. where one chain may be better or may be worse, but the result is uncertain). This task therefore summarises all the key regions under which chains “with” pre-processing are cheaper, more efficient or lower emission than their counterfactual chain “without” pre-processing.

Venn diagrams for the LCOE delta have been included for all the pairs of chains, including all of the variables that were flagged up³⁸ during the selection process for the crossover charts (whether or not they actually lead to a base case line crossover). For the GHG emissions delta and efficiency delta metrics (which are given in separate Venn diagrams), CMCL only included the variables that have regions that fall in the middle section of the Venn diagrams (“may be preferred”), and excluded any parameters where the chain “without” pre-processing is always clearly better. Some Venn diagrams have been left out entirely because all the parameters fall on the left (without pre-processing is clearly better), and so all the parameters are excluded.

The boundaries shown in the Venn diagrams are taken from where the prediction interval lines (the dashed lines) cross the $y = 0$ line, i.e. when one chain is clearly preferred over the other, even considering 95% of the inherent uncertainties in the modelling. If the base case line crosses the $y=0$ line then this is indicated by ranges in both of the central columns. The column in which the base case value (with its base case prediction interval) is located is denoted by a black dot at the bottom of each Venn diagram.

Note that if a lower probability (e.g. 70%) had been used to mark out the prediction intervals for the uncertainty scatter points in Section 5.1, then the position of the base case line or scatter points would not change, but the cross-over charts would all have narrower bands marked out between the dashed lines. This would mean that more instances with “clear” cross-overs would occur, because the dashed lines would be closer to the base case line when it crosses-over. However, these “clear” cross-overs would then be inherently less clear, because the probability of these results being correct is lower. We chose a 95% probability to bound an area on the cross-over charts, so that we can be sure of any cross-over findings made.

³⁸ Note that not all the parameters that are included in these Venn diagrams have been plotted as cross-over charts. Many were not plotted as cross-over charts, because there was not significant movement between boxes in the Venn diagram (not interesting to plot), or because they show the same behaviour as another plotted parameter, or the same behaviour as between LCOE, efficiency or GHG metrics.

5.2.1 Chain 2 vs. Chain 1

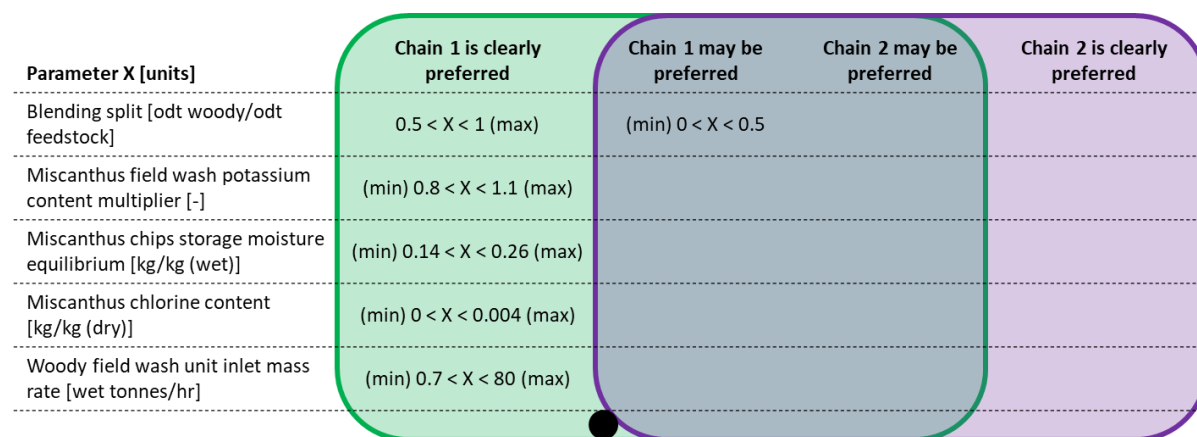

Figure 5.18: Chain 1 vs. 2 LCOE Venn diagram

As an explanation of how to read the first Venn diagram (Figure 5.18), those parameters that are able to significantly influence the LCOE delta for Chain 2 vs. 1 have been selected, and included on the column on the far left. These parameter names and units match those used in the cross-over charts and spider diagrams. As a reminder for each parameter, the minimum and maximum values are denoted by (min) or (max) next to the relevant values.

Taking the first row, for the blending split X . Where the blending split is between 0.5 and 1 (i.e. the proportion of woody feedstocks is between 50-100%), then “Chain 1 is clearly preferred”, even with the uncertainties. This is denoted by $0.5 < X < 1$, in the left-hand green box. This parameter region is when both the prediction interval dashed lines are at³⁹ or above $y=0$ in Figure 5.1. For blending split values between 0 and 0.5, then the base case line does not cross-over, but there are regions of the prediction interval that have crossed-over, indicating that there are further parameters choices and optimisations that could be made to enable a cross-over. This is denoted by $0 < X < 0.5$ in the second column “Chain 1 may be preferred”. As the base case line does not cross-over, the final two columns are empty.

For Miscanthus field washing potassium multiplier, Miscanthus chips storage moisture equilibrium, Miscanthus chlorine content, and Woody field wash unit inlet mass rate, these all have some impact on the LCOE delta, but are all still in the “Chain 1 is clearly preferred category”, as their prediction intervals do not reach $y=0$.

The location of the black base case dot shows that the base case LCOE value for Chain 1 is lower than in Chain 2, but that the lower prediction interval for the LCOE delta is on the cusp of reaching $y=0$. So at the base case with its prediction interval, there is only just a clear preference for Chain 1.

There are no other Venn diagrams for Chain 2 vs. 1, as the parameters were all excluded from the potential GHG emission and efficiency Venn diagrams due to all falling in the far left green box (as would the black base case dots). So, in summary, only the blending split is able to move away from Chain 1 clearly being preferred, but still not achieve a cross-over. However, in combination with other parameter changes, Miscanthus heavy supply chains are more likely to benefit from the addition of field washing than Woody heavy supply chains.

³⁹ This process of checking when the dashed lines cross is done manually, and so values are approximate.

5.2.2 Chain 4 vs. Chain 3

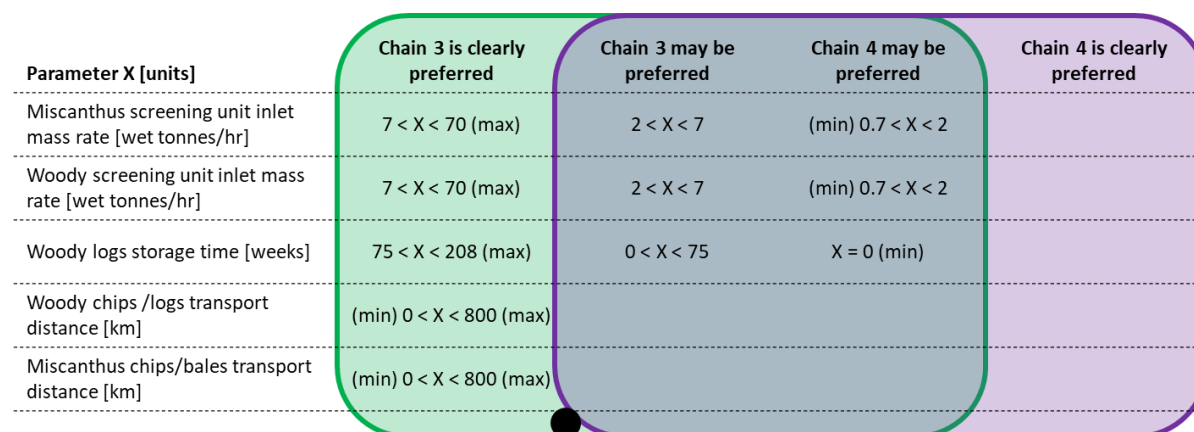

Figure 5.19: Chain 3 vs. 4 LCOE Venn diagram

At the black base case dot with its prediction interval, there is only just a clear preference for Chain 3.

The screening unit scale parameters fall into three categories. At large scales for Miscanthus and woody screening units, Chain 3 is clearly preferred. A cross-over is only achieved at <2 wet tonnes/hr, but this is uncertain, and due to Chain 3 having high costs rather than Chain 4 costs falling (the screening scale parameters do not impact Chain 4).

Woody log storage times below 75 weeks suggest that depending on other parameters, some cross-overs might be possible, but Chain 3 is still likely to be preferred. A cross-over only just happens at 0 weeks (this is denoted by $X = 0$ on the Venn diagram), but this is still uncertain, and does not show a clear preference for Chain 4. Varying the transport distances does not change the clear preference for Chain 3.

There are no other Venn diagrams for Chain 4 vs. 3, as the parameters were all excluded from the potential GHG emission and efficiency Venn diagrams due to all falling on the far left green box (as would the black base case dots).

So, in summary, only very small/expensive screening units or zero log storage time result in conditions that might achieve a possible cross-over. Water washing and pelleting are therefore unlikely to benefit supply chains, unless the feedstock being used in gasification is currently very wet, and/or the existing screening equipment is expensive and poorly utilised. However, in these situations, it is very likely that just warehouse natural drying and pelleting alone would be able to sort out the wet feedstock problem (without the water washing step), and this new set-up would be cheaper than both Chain 3 or 4. The addition of the water washing step does not solve any of the major cost issues highlighted by the selected parameters.

5.2.3 Chain 6 vs. Chain 5

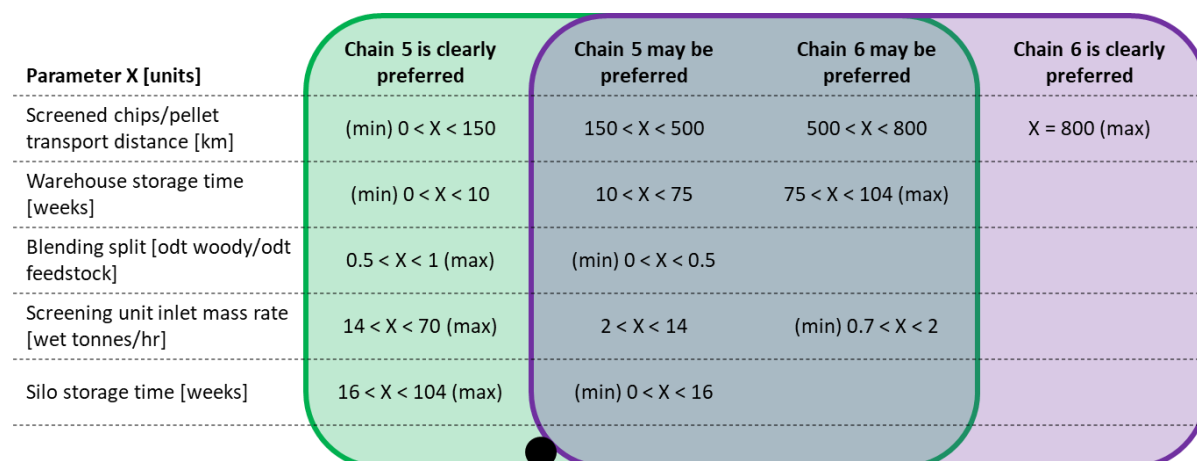

Figure 5.20: Chain 5 vs. 6 LCOE Venn diagram

At the black base case dot with its prediction interval, there is only just a clear preference for Chain 5.

The screened chips/pellet transport distance falls into all four Venn diagram categories. At short distances, Chain 5 is clearly preferred. Up to the base case cross-over at 500km, Chain 5 may be preferred, and from 500 to 800km, Chain 6 may be preferred. At the maximum distance of 800km, the cross-over is just fully completed, and Chain 6 is clearly preferred – i.e. the merits of trucking pellets instead of chips have outweighed the extra costs of pelleting over screening. This would very likely also apply were even longer distances considered in the model (i.e. >800km).

The warehouse storage time only applies to increase Chain 5 costs, and does not impact Chain 6. For very short storage times Chain 5 is clearly preferred, otherwise the picture is uncertain. However, given the upper dashed line is almost at $y=0$, it is likely that slightly longer warehouse storage times (say above ~ 120 weeks) would also show a clear preference for Chain 6, due to the added warehouse costs and chip degradation. However, this analysis is in isolation from the silo storage time, which may also be changing. High silo storage times clearly favour Chain 5, due to the significant added silo costs and some pellet degradation, but low silo storage times leave the situation unclear.

Similar to the Chain 2 vs. 1 LCOE Venn diagram, there is no cross-over when varying the Blending split, but chains with more Miscanthus are more likely to find cross-over conditions. This is due to the lower density of Miscanthus bales and chips compared to woody logs and chips.

Similar to the Chain 4 vs. 3 LCOE Venn diagram, there is a potential cross-over when the screening scale become very small, and hence expensive.

So, in summary, only very long chip transport distances are able to achieve a clear LCOE cross-over. Long chip storage times in warehouses may achieve a cross-over, but are unlikely to do so if also choosing the same silo storage time (as silo costs are much higher than warehouse costs). The use of very small/expensive screening units may also result in a cross-over. Pelleting in Chain 6 is therefore more likely to benefit those supply chains with the longest distances, with very long/large chip storage buffer requirements, with very low density feedstocks such as Miscanthus, and those situations where the existing screening equipment is expensive and poorly utilised.

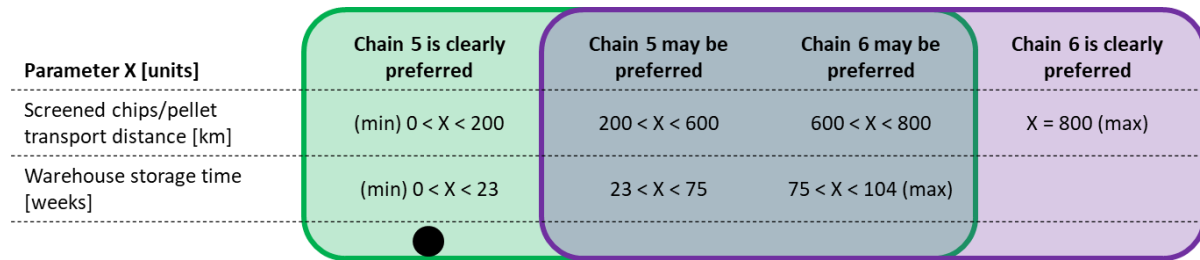

Figure 5.21: Chain 5 vs. 6 net efficiency Venn diagram

At the black base case dot with its prediction interval, Chain 5 is clearly preferred.

There are only a few parameters that sufficiently influence the net chain efficiency delta to achieve possible cross-overs. These are the screened chip/pellet transport distance, and warehouse storage time (in isolation). These have slightly different change points between the Venn diagram sections, but the overall message is the same – long transport distances and long chip storage times clearly favour Chain 6 pelleting over Chain 5 screening. The other LCOE Venn parameters, such as blending split, screening unit scale and silo storage time do not have enough impact on the net chain efficiency to be included.

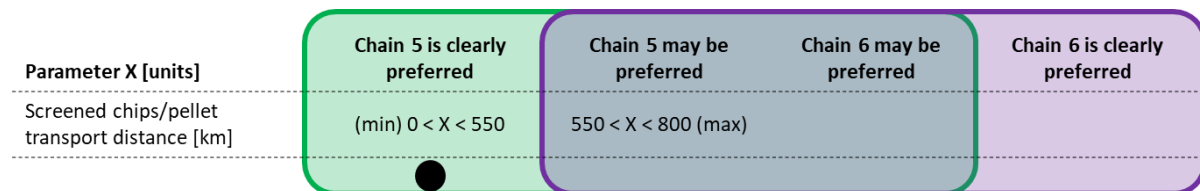

Figure 5.22: Chain 5 vs. 6 GHG emissions Venn diagram

At the black base case dot with its prediction interval, Chain 5 is clearly preferred.

The transport distance is the only parameter that is able to sufficiently influence the GHG emissions delta to prevent Chain 5 being clearly preferred, but even then, its impact is limited. Ultimately, very long transport distances would have to be considered for the transport fuel savings to outweigh the electricity, binder and other smaller energy inputs to pelleting.

5.2.4 Chain 7 vs. Chain 5

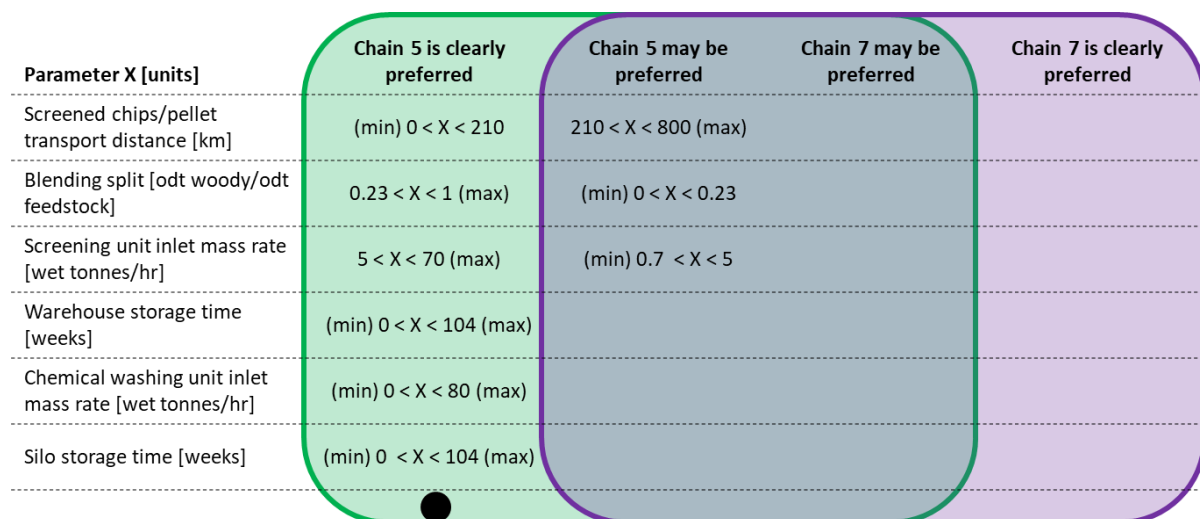

Figure 5.23: Chain 5 vs. 7 LCOE Venn diagram

At the black base case dot with its prediction interval, Chain 5 is clearly preferred.

Unlike Chain 6 vs. 5, the screened chips/pellet transport distance for Chain 7 vs. 5 only falls into two Venn diagram categories. At short to medium distances, Chain 5 is clearly preferred, and then up to the maximum 800km, the situation is less clear.

The warehouse storage time applies to increase both the Chain 5 and Chain 7 costs, so even up to 2 years of storage is not enough to avoid Chain 5 clearly being preferred. This also applies to the Chain 7 silo storage time, which only adds costs to Chain 7, and drives the LCOE delta more positive. Varying the chemical washing unit scale also influences the Chain 7 LCOE, but not enough to cause any uncertainty about the clear preference for Chain 5. Only the very smallest screening units might cause Chain 5 not to be clearly preferred.

Similar to the Chain 6 vs. 5 LCOE Venn diagram, there is no cross-over when varying the Blending split, but chains with a large majority of Miscanthus are more likely to find cross-over conditions. This is due to the lower density of Miscanthus bales and chips compared to woody logs and chips raising costs in Chain 5.

So, in summary, there are no single parameter changes that achieve a possible cross-over. Chemical washing and pelleting are therefore very unlikely to benefit supply chains, unless there is a unique combination of factors such as using only Miscanthus, extremely long distances, and where the existing screening equipment is extremely expensive and poorly utilised – and even this combination (as yet untested) might not be enough to achieve a possible cross-over. However, in these situations, it is likely that just natural drying and pelleting alone would be able to sort out the density issues raised, and this new set-up would be cheaper than 7. The addition of the chemical washing step does not solve any of the major cost issues highlighted by the selected parameters.

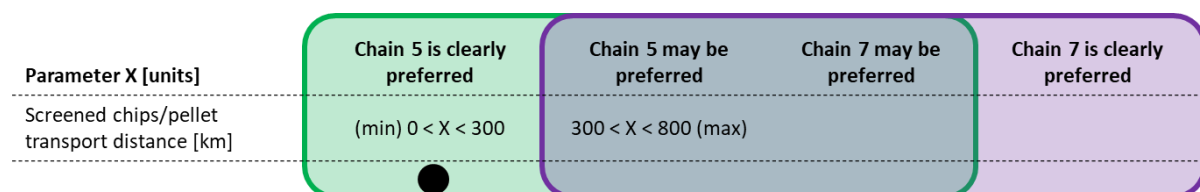

Figure 5.24: Chain 5 vs. 7 net efficiency Venn diagram

At the black base case dot with its prediction interval, Chain 5 is clearly preferred.

The transport distance is the only parameter that is able to sufficiently influence the net efficiency delta to prevent Chain 5 being clearly preferred, but even then, its impact is limited. Ultimately, extremely long transport distances would have to be considered for the transport fuel savings to outweigh the electricity and other energy inputs used in both chemical washing and pelleting.

The Venn diagram for the GHG emissions delta is empty, as no parameters are able to move out of the “Chain 5 is clearly preferred” region, where the black base case dot also sits.

5.2.5 Chain 9 vs. Chain 8

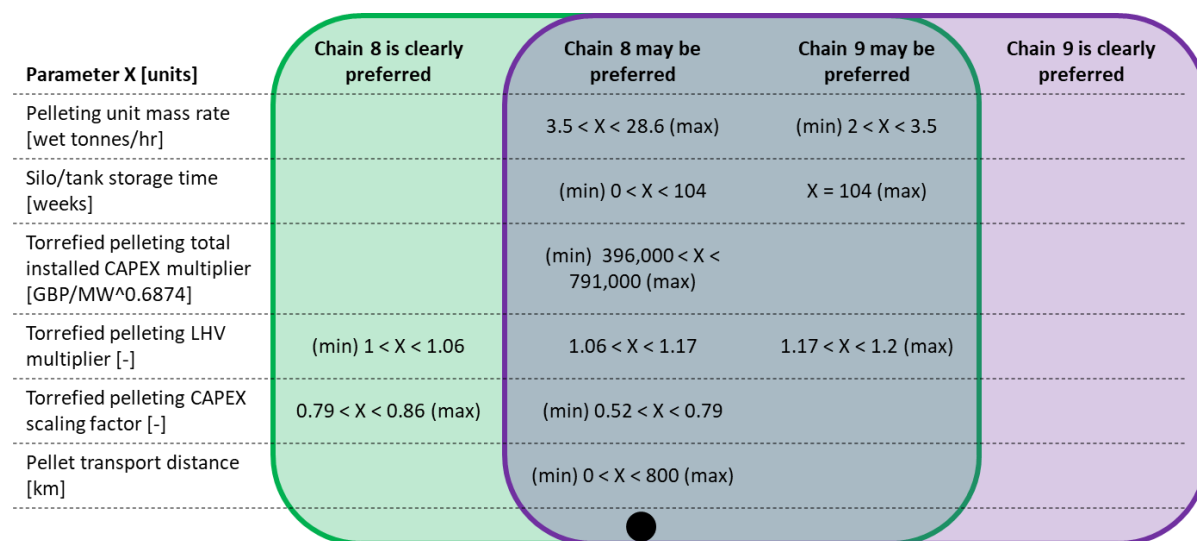

Figure 5.25: Chain 8 vs. 9 LCOE Venn diagram

At the black base case dot with its prediction interval, Chain 8 may be preferred.

Many of the parameters selected already fall into the “Chain 8 may be preferred” category, because Chain 8 includes the significant costs of pelleting. The cross-over status of the pellet unit scale is uncertain, but very small pellet plants favour Chain 9 (as the scale of the torrefaction + pelleting plant used in Chain 9 is assumed to be independent from the scale of the pelleting plant in Chain 8, i.e. does not get smaller as the Chain 8 pellet plant scale is reduced).

Silo storage times almost always favour Chain 8, but at the highest storage times (or longer), there may just be cross-over, and so Chain 9 may be preferred. This is due to the higher torrefied pellet LHV density making silo storage cheaper than for standard pellets⁴⁰. However, despite this uplift in LHV, the slight improvement in trucking costs does not have enough impact to shift the preference between Chain 8 and 9, i.e. a cross-over is not achieved (it would need ~1420km to do so).

Similarly, whilst a minimised torrefaction + pelleting CAPEX has an important impact, it is not quite enough to achieve a cross-over where Chain 9 may be preferred. And were a high CAPEX scaling factor chosen (when rescaling from the reference data source), the increased cost of the torrefaction + pelleting plant would actually cause Chain 8 to be clearly chosen over Chain 9.

The torrefied pelleting LHV multiplier falls into three categories. If there is a <6% increase in LHV during torrefaction, Chain 8 is clearly preferred. However, if an uplift of more than 17% is achieved, then Chain 9 may be preferred (although still uncertain).

So, in summary, only very long silo storage times, extremely long distances (well outside the model boundary) and high LHV torrefied pellets are able to achieve a possible cross-over. Very small pelleting plants might also cause a cross-over, but only if it is assumed the torrefaction + pelleting plant is still at its base case scale. Therefore, well optimised torrefaction plants achieving high LHV

⁴⁰ As discussed in Section 7.2.9, there are time limitations to the outdoor storage of torrefied pellets, given issues with significant moisture gains, disintegration and degradation/mould. Given the gPROMS user defines the storage time in TEABPP, it was more appropriate to include a pellet silo in the Chain 9 architecture, as it is more likely that torrefied pellets would be stored in a silo than be stored outdoors in exposed conditions for anything more than a very short period (study data does not quantify this period precisely).

pellets are therefore most likely to help those supply chains with very large storage/buffer requirements, or extremely long transport distances. There are no biomass parameters listed above, i.e. torrefaction is not expected to help with the cost of dealing with biomass elemental properties.

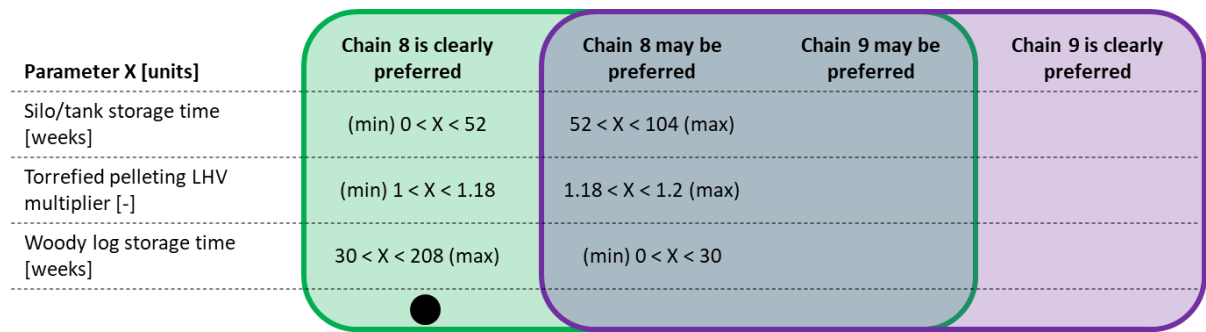

Figure 5.26: Chain 8 vs. 9 net efficiency Venn diagram

At the black base case dot with its prediction interval, Chain 8 is clearly preferred.

Standard pellets take up more volume, so will consume more power to operate the silos, than torrefied pellets. Standard pellets also have ~10% moisture content, so will degrade faster than torrefied pellets at only ~2% moisture. Both these factors mean long silo storage times favour torrefied over standard pellets – but this is not enough to enable a possible efficiency cross-over.

Short woody log storage times mean that the biomass arriving at the pre-processing plant is wetter, and this has a slightly greater impact on the pelleting plant, due to needing to burn some of the input biomass to provide drying – and the boiler used to raise this heat will operate less efficiently with the wetter biomass. In the torrefaction + pelleting plant, the wetter biomass does still have some impact in lowering the step efficiency, but the drying is carried out using combustion of the torrefaction gases, which is assumed to not have as large a moisture efficiency penalty as pelleting.

And as above, a higher LHV for the torrefied pellets enables slightly less diesel to be used in transport, and less power in storage, improving the chain net efficiency.

So, the silo storage time, torrefied pellet LHV multiplier and woody log storage times are the only parameters that are able to sufficiently influence the net efficiency delta to prevent Chain 5 being clearly preferred, but not enough for a possible cross-over.

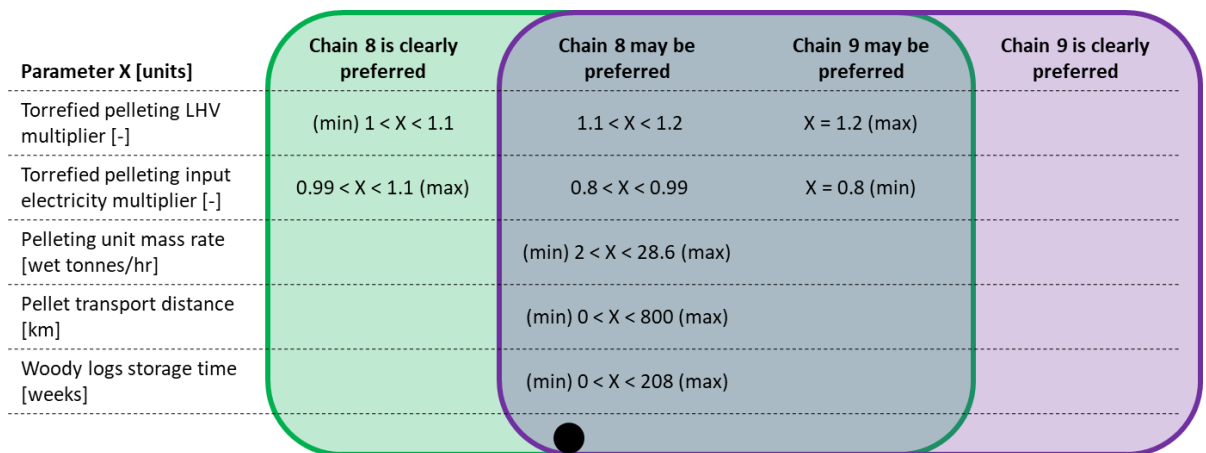

Figure 5.27: Chain 8 vs. 9 GHG emissions Venn diagram

At the black base case dot with its prediction interval, Chain 8 is very likely to be preferred, but is not “clearly preferred” (as per the 95% probability definition).

As above, a higher LHV for the torrefied pellets enables slightly less diesel to be used in transport, and less power in storage, improving the chain GHG emissions. The maximum LHV multiplier ($X = 1.2$) just achieves a cross-over, where Chain 9 may be preferred, but the result is uncertain.

Similarly, the torrefied pelleting input electricity multiplier just achieves an uncertain cross-over at its minimum value ($X = 0.8$), as the electricity consumption within the torrefaction + pelleting plant is not small, nor is the grid GHG intensity factor used. Note that the torrefied pelleting input electricity multiplier changing does not assume any improvement within just the Chain 8 pelleting plant electricity use, as these are independent input parameters.

The pelleting unit mass rate only changes the GHG emissions of Chain 8, but the Venn diagram results remain uncertain and still likely preferring Chain 8, regardless of the pellet plant scale – this is because the per tonne inputs into the pelleting step do not change much at larger scales. Changes in the pellet transport distance and the woody logs storage time impact the GHG emissions of both Chain 8 and 9, but without sufficient differences in the pellet energy densities, or the energy use for drying wetter biomass in pelleting plants vs. torrefaction + pelleting plants, to be able to drive a cross-over or clear preference for Chain 8.

5.2.6 Chain 10 vs. Chain 8

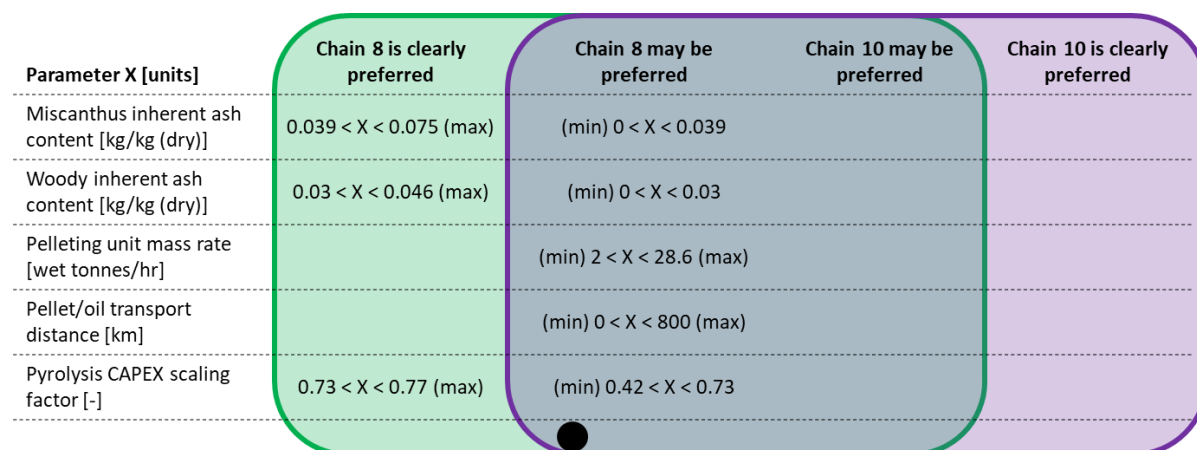

Figure 5.28: Chain 8 vs. 10 LCOE Venn diagram

At the black base case dot with its prediction interval, Chain 8 is very likely to be preferred, but is not “clearly preferred” (as per the 95% probability definition).

As with Chain 9 vs. 8, many of the parameters selected for Chain 10 vs. 8 already fall into the “Chain 8 may be preferred” category, because Chain 8 includes the significant costs of pelleting. Note that because the uncertainties are so wide in Chain 10, achieving a clear preference is much rarer.

Some of the parameters selected only stay in the “Chain 8 may be preferred” category. Choosing a smaller or larger pelleting plant, despite only impacting Chain 8 costs, is not enough to cause a cross-over or a clear preference for Chain 8. Similarly, varying the transport distance does not have a dramatic impact – although a bio-oil tanker has slightly lower per tonne-km costs than a pellet truck, the ~25% moisture content in the bio-oil means that the tanker costs are slightly higher per MWh-

km (and this moisture content impacts on the EF gasifier efficiency) – so longer transport distances do not have a cost benefit when comparing bio-oil to standard pellets.

If a high pyrolysis CAPEX scaling factor were chosen (when rescaling from the data source), the increased cost of the pyrolysis plant would actually cause Chain 8 to be clearly chosen over Chain 10.

The ash content of the input feedstocks (whether Miscanthus or woody) is a key determinant of the pyrolysis efficiency, and so inherent ash content values above 3-4% lead to a clear LCOE preference for Chain 8 over Chain 10. Miscanthus has a higher maximum, towards which Chain 8 is very clearly preferred (but when the derived relationships break down/warning flags are raised in gPROMS).

So, in summary, there are no single parameter changes that achieve a possible cross-over. Pyrolysis is therefore very unlikely to benefit supply chains, unless there is a unique combination of factors such as using very low ash forestry with minimal soil & stone contamination, very large, low cost and highly efficient pyrolysis technology is available, and the existing pellet mills are very small and poorly utilised – and even this combination (as yet untested) might not be enough to achieve a possible cross-over.

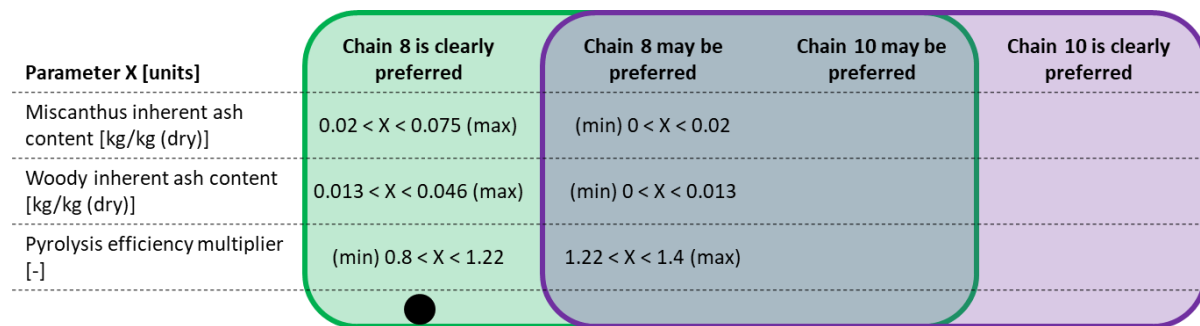

Figure 5.29: Chain 8 vs. 10 net efficiency Venn diagram

At the black base case dot with its prediction interval, Chain 8 is clearly preferred.

As explained above, the feedstock ash is a primary driver of pyrolysis efficiency, which then in turn impacts the LCOE. Therefore, the levels at which Chain 8 becomes clearly preferred are lowered to 1-2% inherent ash contents when considering the net efficiency delta metric instead of the LCOE metric. The pyrolysis efficiency multiplier has an obvious impact, and needs to be at least 22% above current levels for even Chain 8 not to be clearly preferred (i.e. for there to be some chance of a cross-over).

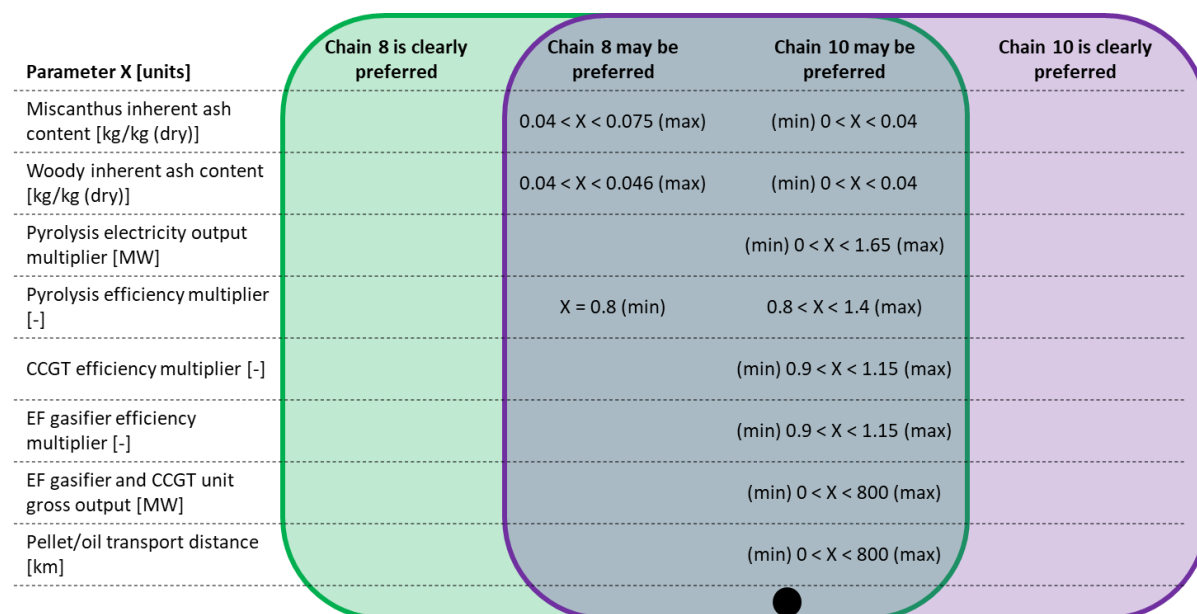

Figure 5.30: Chain 8 vs. 10 GHG emissions Venn diagram

At the black base case dot with its prediction interval, Chain 10 may be preferred.

Given the position of the base case GHG emissions for Chain 10 below that of Chain 8, and the wide uncertainty present in Chain 10, most of the parameters selected automatically fall into the “Chain 10 may be preferred” category.

Higher EF gasifier efficiencies and higher CCGT efficiencies (either via technical development, or via larger unit scale) improve both Chain 8 and 10, so their impact on the GHG emissions delta is relatively limited. However, the higher GHG emissions of Chain 8 will likely be reduced slightly further in absolute terms than the already low GHG emissions of Chain 10.

The bio-oil tanker and pellet truck have very similar diesel consumption figures when looking at per MWh-km, so the transport distance has a limited impact on the GHG emissions delta.

Higher pyrolysis efficiency improves the GHG emissions of only Chain 10, as does a higher export of co-product electricity from the pyrolysis plant, but the uncertainties are so large that there is not a confirmed clear preference for Chain 10. If the pyrolysis efficiency is minimised, then the GHG emissions of Chain 8 may just be preferred. Similarly, if the feedstock inherent ash content is above 4%, the efficiency drops, and so Chain 8 is likely to be preferred as well.

5.3 Summary of cross-over findings

In summary, there are very few parameters which populate the furthest right-hand side of the Venn diagrams, where the chain “with” pre-processing is better than the chain “without” pre-processing. The only chain pairing and metrics where these clear cross-overs occur are for the Chain 6 vs. 5 LCOE delta and the Chain 6 vs. 5 net efficiency delta, both when the screened chip/pellet transport distance reaches 800km (or above). At this point, the benefits of adding pelleting clearly outweigh the costs.

There are several chain pairings and metrics where the chain “with” pre-processing may be better, i.e. the base case line has crossed over, but the uncertainties are still too large to confirm this accurately. These include:

- Chain 4 vs. 3 LCOE may be preferred with zero woody log storage time, or with very small screening units being used in Chain 3
- Chain 6 vs. 5 LCOE may be preferred between 500 and 800km for the screened chip/pellet transport distance, or above 75 weeks warehouse storage time, or with very small screening units being used in Chain 5
- Chain 6 vs. 5 efficiency may be preferred between 600 and 800km for the screened chip/pellet transport distance, or above 75 weeks warehouse storage
- Chain 9 vs. 8 LCOE may be preferred with very small pelleting plants, above 104 weeks silo storage time, or a torrefaction LHV multiplier above 1.17
- Chain 10 vs. 8 GHG emissions may be preferred for all the parameters across their input ranges, except for when pyrolysis efficiency multiplier is minimised, or when feedstock inherent ash contents are >4% (at which point Chain 8 may be preferred instead).

There are a very large number of chain pairings and metrics where the chain “without” pre-processing may be better, or where the chain “without” pre-processing is clearly better, which will not be listed here. However, the following Table 5.1 summarises the position of the base case results and the uncertainties, and Table 5.2 summarises how many parameters have the ability on their own to achieve an uncertain (or clear) cross-over.

Table 5.1 uses the following terminology and colour coding:

- **Red:** indicates the base case is sitting on the far left of the Venn diagram, i.e. a clear preference in favour of the chain without pre-processing
- **Brown:** indicates the base case is sitting right near the cusp between the two Venn diagram columns, and there is either only just a clear preference for the chain without pre-processing or it is very likely to be preferred (but is not quite clearly preferred)
- **Orange:** indicates the base case is sitting within the second column of the Venn diagram, i.e. an uncertain result that may favour the chain without pre-processing
- **Green:** indicates the base case is sitting within the third column of the Venn diagram, i.e. an uncertain result that may favour the chain with pre-processing

Table 5.1: Comparison of base case chain preferences under uncertainty

| Chain pair | LCOE delta | Net efficiency delta | GHG emissions delta |
|------------|-------------------------------|------------------------|-------------------------------|
| 2 vs. 1 | 1 is clearly/may be preferred | 1 is clearly preferred | 1 is clearly preferred |
| 4 vs. 3 | 3 is clearly/may be preferred | 3 is clearly preferred | 3 is clearly preferred |
| 6 vs. 5 | 5 is clearly/may be preferred | 5 is clearly preferred | 5 is clearly preferred |
| 7 vs. 5 | 5 is clearly preferred | 5 is clearly preferred | 5 is clearly preferred |
| 9 vs. 8 | 8 may be preferred | 8 is clearly preferred | 8 may be/clearly is preferred |
| 10 vs. 8 | 8 may be/clearly is preferred | 8 is clearly preferred | 10 may be preferred |

Many pairs of chains have base case results on the cusp of clearly/may be preferred when looking at the LCOE delta, but only the Chain 9 base case (involving torrefaction + pelleting) is found in the

second column of the Venn diagram. When looking at the net efficiency delta, all of the chain pairs show a clear preference for the chain with the least pre-processing at the base case, which suggests that adding pre-processing will incur a significant energy penalty to the overall chain (despite some benefits, e.g. in trucking) unless mitigating actions taken or improvements made. The net efficiency has a large part to play in determining the chain GHG emissions, which explains why many chain pairs also show the same clear preference (in red) – with the exception of Chain 9 on the cusp, and Chain 10 with its self-sufficient pyrolysis unit that may be preferred already at the base case.

Table 5.2 uses the following terminology and colour coding:

- **Red:** no independent parameter changes can achieve an (unclear) cross-over
- **Orange:** at least one independent parameter can achieve an (unclear) cross-over, but there are no clear cross-overs
- **Green:** at least one independent parameter can achieve a clear cross-over, even if at the extreme edge of its min-max range

Table 5.2: Comparison of the ability of chains to achieve cross-overs

| Chain pair | LCOE delta | Net efficiency delta | GHG emissions delta |
|------------|---|--|---|
| 2 vs. 1 | No options | No options | No options |
| 4 vs. 3 | Few options, but none for a clear cross-over | No options | No options |
| 6 vs. 5 | Some options, and for a clear cross-over | Some options, and for a clear cross-over | No options |
| 7 vs. 5 | No options | No options | No options |
| 9 vs. 8 | Some options, but none for a clear cross-over | No options | Few options, but none for a clear cross-over |
| 10 vs. 8 | No options | No options | Many options, but none for a clear cross-over |

Only Chain 6 vs. 5 has the ability to achieve a clear cross-over, in both the LCOE and net efficiency deltas. Chain 9 vs. 8 has some options to achieve an uncertain cross-over in LCOE and GHG emissions, as does Chain 4 vs. 3 on LCOE only. The GHG emissions base case for Chain 10 vs. 8 already has an uncertain cross-over, so any change in the parameters also achieves an uncertain cross-over – but there are no opportunities for a clear cross-over. The rest of the chain pairs and metrics have no options for independent parameter cross-overs.

Together, these mean that there are options for pelleting to clearly out-perform screening, and potentially some options for torrefaction + pelleting to out-perform pelleting – whilst pyrolysis only has the potential benefits of low GHG emissions. Other pre-processing options such as field wash and chemical washing do not have a significant chance of achieving chain benefits, and the benefits of water washing then pelleting over screening are dominated by the pelleting benefits.

6 Optimisation opportunities

This section assesses the optimal case results for each chain (varying identified technical parameters only), and then examines the real-world innovation improvements that are most likely to be responsible for these improvements in chain cost, efficiency and GHG emissions from the base case.

6.1 Select parameters to optimise

For each chain, E4tech and ICON have selected those input parameters which should be held fixed at their base case, and those that will be allowed to be optimised. The focus of the TEABPP project is on the impact of technical innovation in pre-processing and conversion technologies, so we have only allowed conversion or pre-processing parameters to vary where B&V, ICON or Sheffield have identified a possible improvement (as given in the D2 Excel) – all other technical parameters without an identified improvement have been held fixed at their base cases.

We have also fixed all the feedstock, transport and storage parameters at the base cases – with the one exception of allowing the storage times to vary. We have also held capacities, availabilities, capex scaling factors, energy demands, blending fractions, discount rate, and all the material/waste costs and GHG emissions factors at their base cases, to allow a proper comparison between the base case results and the optimum case results. The full list of which parameters were allowed to vary, and which were fixed, is given in the separate Excel workbook “Inputs ranges with innovation”.

6.2 Optimise by inspection

For those conversion or pre-processing parameters where possible improvements were identified, the current min-max uncertainty ranges were extended by B&V, ICON and Sheffield to account for the impact of specific innovation activities. For example, if a hypothetical capex value has a current uncertainty range of -20% to +20%, and identified innovations are expected to lower capex by 30%, the min-max range for the parameter was extended to -50% to +20%. These ranges are given in the Excel workbook “Inputs ranges with innovation”. The innovation activities underpinning these improvements are all briefly outlined in the D2 Excel, and those activities found to be the most important are described in more detail, with targets, below in Section 6.5.

Then for these parameters that have widened min-max ranges (all those with identified improvements), E4tech and ICON chose the best outcomes for each parameter, based on inspection and engineering logic of whether to minimise or maximise each of the allowed parameters. This included minimising capital and operating costs (e.g. in the example above, choosing -50% as the optimum capex value), maximising efficiencies, and generally minimising material and energy use parameters (some parameters were maximised, as they apply as an inverse relationship within the gPROMS formulae). This logic is explained in greater detail in the first tab of the Excel workbook “Inputs ranges with innovation”.

Almost every parameter is monotonic, i.e. we were able to take the minimum or maximum value in order to achieve the lowest cost, lowest GHG emissions and highest efficiency. This was checked by CMCL during the pie chart and spider chart sensitivity analysis. Storage times have a drying vs. degradation trade-off, and hence are non-monotonic (i.e. they have a cost curve over time). We therefore used information from the D2 Excel and the spider diagrams, plus cross-checking with the gPROMS model to manually find optimum input values for the storage times.

6.3 Optimum case results

Similar to the base case results above in Section 4.3, and given the chain architectures remain unchanged, PSE have used the chosen optimum input values from Section 6.2 above to produce LCOE component breakdown charts in the gPROMS interface for the 10 chains. The results on the following charts are therefore justified by the underpinning innovation assumptions made in Section 6.2, as set out in the D2 Excel and Section 6.5.

Table 6.11 further below compares the optimum case values across all 10 chains (for LCOE, efficiency and emissions metrics), to show if significant innovation efforts are able to achieve cross-overs, and the extent of the possible improvements from the base case values. The reasons behind the improvements in each chain are discussed in Section 6.5 below.

6.3.1 Chain 1 – Underfeed stoker combustion boiler with screening

The results for the optimised case in Chain 1 are presented below. For this chain, a total of 16 parameters were optimised.

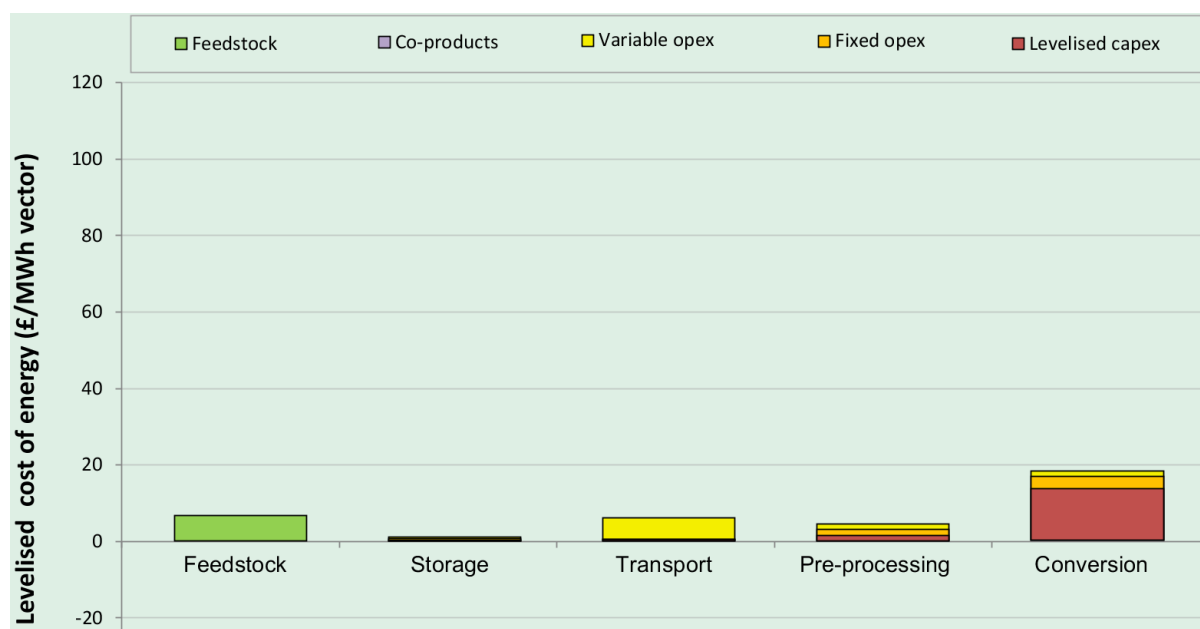

Figure 6.1: Chain 1 optimum case LCOE component breakdown

Table 6.1: Chain 1 optimum case LCOE component breakdown

| Costs (£/MW _{th}) | Feedstock | Storage | Transport | Pre-processing | Underfeed boiler | Total |
|-----------------------------|------------|------------|------------|----------------|------------------|-------------|
| | | | | Screening | | |
| Feedstock | 6.3 | - | - | - | - | 6.3 |
| Co-products | - | - | - | 0 | - | 0.0 |
| Variable OPEX | - | 0.1 | 5.7 | 1.4 | 1.4 | 8.7 |
| Fixed OPEX | - | 0.1 | - | 1.8 | 3.2 | 5.2 |
| Levelised CAPEX | - | 0.3 | - | 1.0 | 13.2 | 14.5 |
| Total | 6.3 | 0.6 | 5.7 | 4.2 | 17.9 | 34.6 |

Figure 6.1 shows the component breakdown of the Chain 1 optimum case net chain LCOE – overall, the total LCOE has fallen 35% from the base case. Compared with Figure 4.2, the component breakdown for the optimised case is similar to the base case. The most important contribution to the LCOE remains the conversion technology, despite a reduction in conversion costs of 46% from the base case, and specifically, the levelised CAPEX remains the largest share (at 74%) of the optimised conversion costs. There are only small reductions in the storage, transport and feedstock costs, due mainly to the higher chain efficiency.

6.3.2 Chain 2 – Underfeed stoker combustion boiler with screening and field washing

The results for the optimised case in Chain 2 are presented below. For this chain, a total of 49 parameters were optimised.

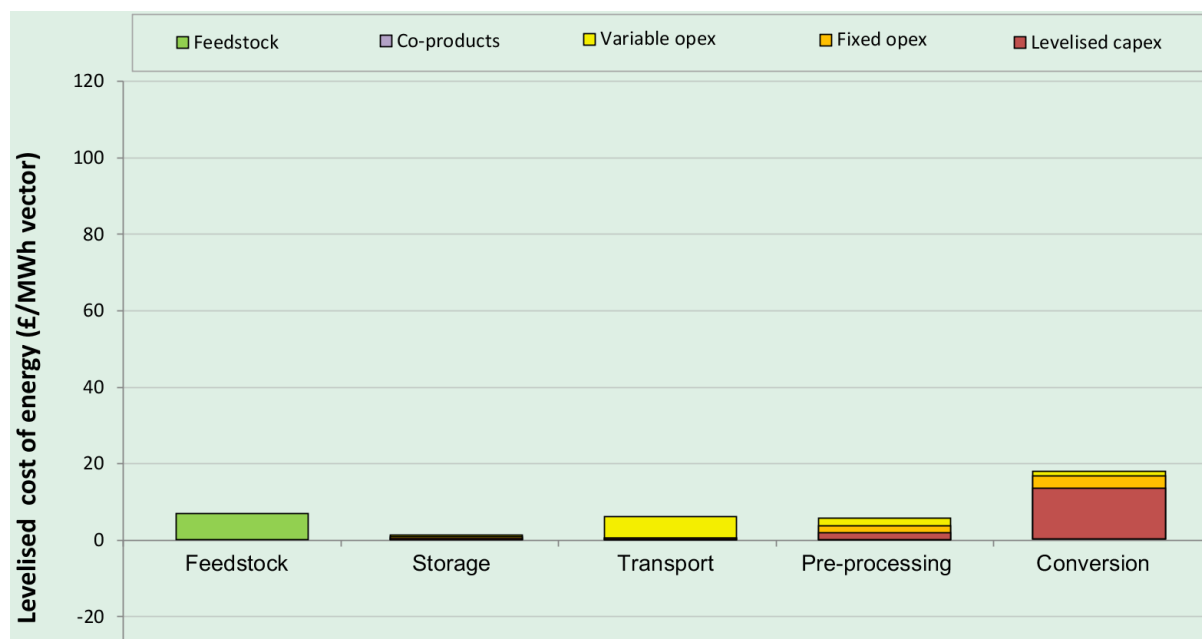

Figure 6.2: Chain 2 optimum case LCOE component breakdown

Table 6.2: Chain 2 optimum case LCOE component breakdown

| Costs (£/MW _{th}) | Feedstock | Storage | Transport | Pre-processing | | Underfeed boiler | Total |
|-----------------------------|------------|------------|------------|----------------|------------|------------------|-------------|
| | | | | Screening | Field wash | | |
| Feedstock | 6.5 | - | - | - | - | - | 6.5 |
| Co-products | - | - | - | 0 | 0 | - | 0.0 |
| Variable OPEX | - | 0.1 | 5.7 | 1.5 | 0.6 | 1.3 | 9.2 |
| Fixed OPEX | - | 0.2 | - | 1.8 | 0.1 | 3.1 | 5.3 |
| Levelised CAPEX | - | 0.5 | - | 1.0 | 0.4 | 13.0 | 14.9 |
| Total | 6.5 | 0.8 | 5.7 | 4.3 | 1.1 | 17.4 | 35.9 |

Figure 6.2 shows the component breakdown of the Chain 2 optimum case net chain LCOE – overall, the total LCOE has fallen 37% from the base case. As for Chain 1, when comparing the base case (Figure 4.4) with the optimised case (Figure 6.2), the component breakdown for both cases is similar. There is a significant fall in the conversion costs of 48% from the base case, although it remains the

main cost in the chain. Similar to Chain 1, there are only small reductions in the storage, transport and feedstock costs, due mainly to the higher chain efficiency in the optimum case.

6.3.3 Chain 3 – BFB gasifier + syngas engine with screening

The results for the optimised case in Chain 3 are presented below. For this chain, a total of 27 parameters were optimised.

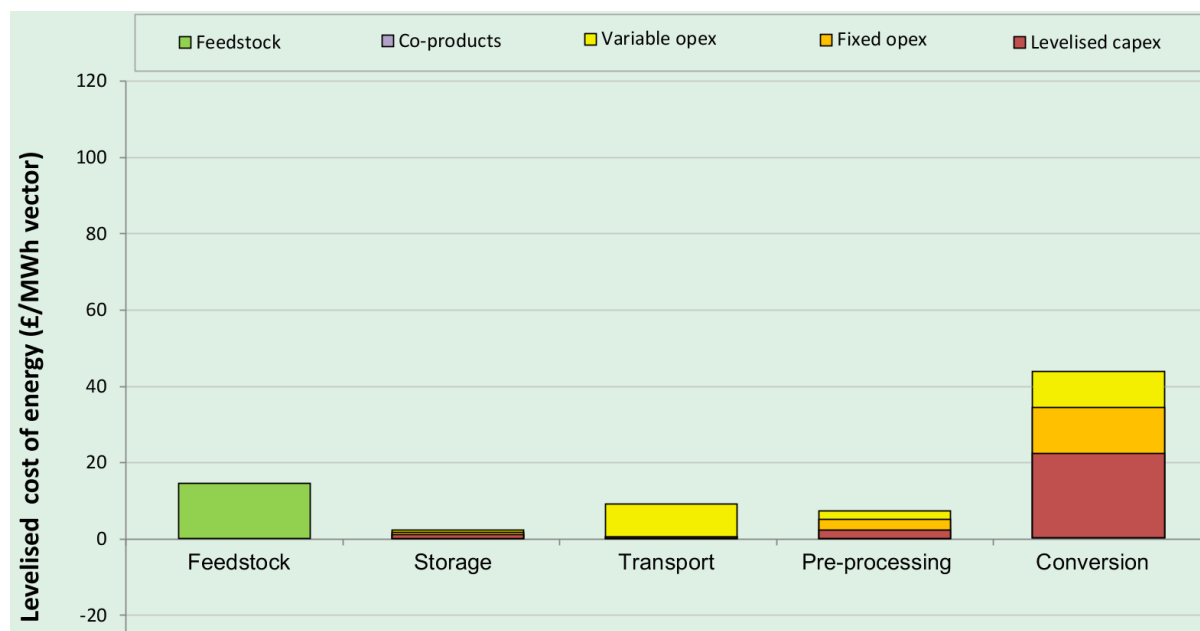

Figure 6.3: Chain 3 optimum case LCOE component breakdown

Table 6.3: Chain 3 optimum case LCOE component breakdown

| Costs (£/MWh _e) | Feedstock | Storage | Transport | Pre-processing | BFB gasifier + syngas engine | Total |
|-----------------------------|-------------|------------|------------|----------------|------------------------------|-------------|
| | | | | Screening | | |
| Feedstock | 14.1 | - | - | - | - | 14.1 |
| Co-products | - | - | - | 0 | - | 0.0 |
| Variable OPEX | - | 0.3 | 8.7 | 2.3 | 9.5 | 20.7 |
| Fixed OPEX | - | 0.5 | - | 2.9 | 12.3 | 15.6 |
| Levelised CAPEX | - | 1.0 | - | 1.9 | 21.7 | 24.6 |
| Total | 14.1 | 1.8 | 8.7 | 7.0 | 43.5 | 75.1 |

Figure 6.3 shows the component breakdown of the Chain 3 optimum case net chain LCOE – overall, the total LCOE has fallen 56% from the base case. Comparing Figure 6.3 with the base case results (Figure 4.6), the BFB gasifier + syngas engine costs are still the main cost within the chain, despite a decrease of 65% from the base case conversion costs. The feedstock costs have also decreased slightly from the base case due to the increase in efficiency (and so less feedstock required). The costs of storage remain relatively unimportant, and there is not a significant change in the relevance of the transport and pre-processing components between the base and optimal cases (only some efficiency improvements in the overall chain that lower their costs).

6.3.4 Chain 4 – BFB gasifier + syngas engine with water washing and pelleting

The results for the optimised case in Chain 4 are presented below. For this chain, a total of 48 parameters were optimised.

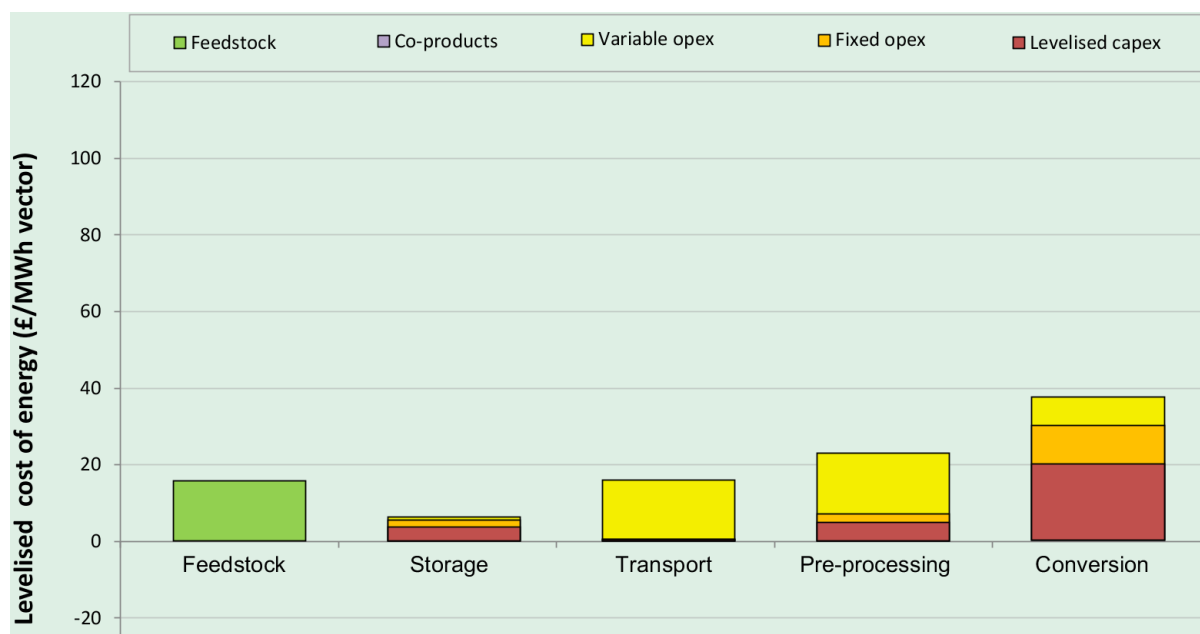

Figure 6.4: Chain 4 optimum case LCOE component breakdown

Table 6.4: Chain 4 optimum case LCOE component breakdown

| Costs (£/MWh _e) | Feedstock | Storage | Transport | Pre-processing | | BFB gasifier + syngas engine | Total |
|-----------------------------|-------------|------------|-------------|----------------|-------------|------------------------------|-------------|
| | | | | Water wash | Pelleting | | |
| Feedstock | 15.3 | - | - | - | - | - | 15.3 |
| Co-products | - | - | - | 0 | 0 | - | 0.0 |
| Variable OPEX | - | 0.6 | 15.6 | 4.4 | 11.6 | 7.5 | 39.7 |
| Fixed OPEX | - | 1.7 | - | 1.2 | 1.1 | 10.2 | 14.3 |
| Levelised CAPEX | - | 3.7 | - | 1.5 | 2.9 | 19.5 | 27.6 |
| Total | 15.3 | 6.0 | 15.6 | 7.1 | 15.6 | 37.3 | 96.8 |

Figure 6.4 shows the component breakdown of the Chain 4 optimum case net chain LCOE – overall, the total LCOE has fallen 51% from the base case. The conversion technology remains the main contribution to the LCOE, as in the base case (Figure 4.8), despite a 62% reduction in the conversion costs. There is also a significant drop of almost 50% in the pre-processing costs, due to identified innovations in water washing and pelleting. There are also smaller decreases in feedstock, storage and transport component costs, due to chain efficiency improvements.

6.3.5 Chain 5 – CFB combustion boiler with screening

The results for the optimised case in Chain 5 are presented below. For this chain, a total of 21 parameters were optimised.

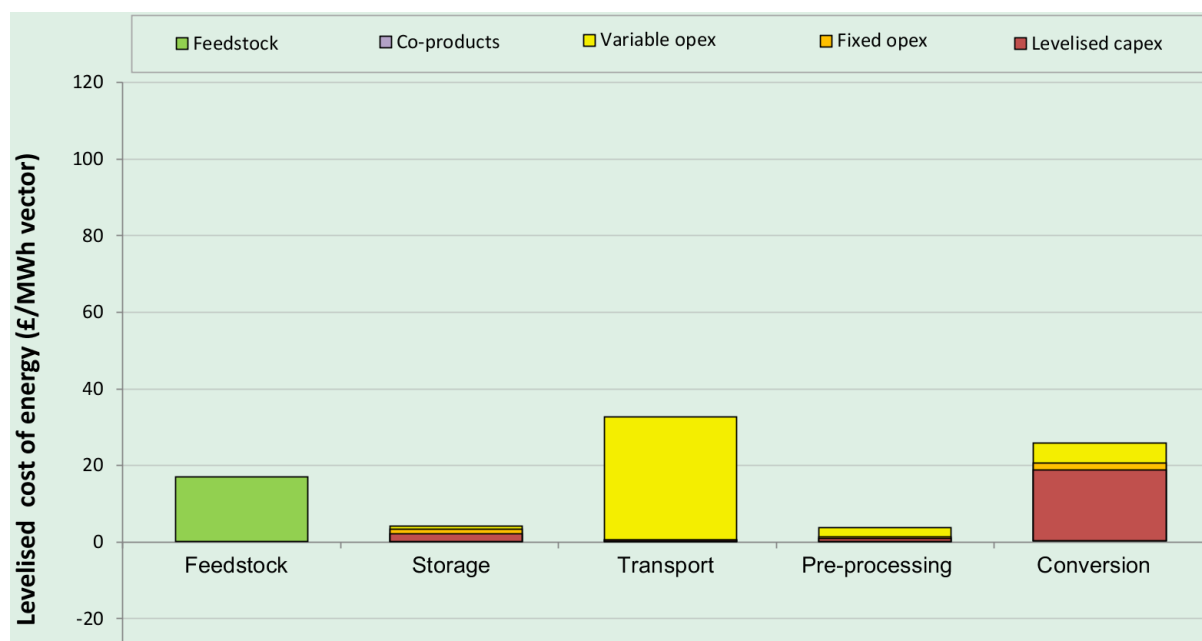

Figure 6.5: Chain 5 optimum case LCOE component breakdown

Table 6.5: Chain 5 optimum case LCOE component breakdown

| Costs (£/MWh _e) | Feedstock | Storage | Transport | Pre-processing | CFB combustion | Total |
|-----------------------------|-------------|------------|-------------|----------------|----------------|-------------|
| | | | | Screening | | |
| Feedstock | 16.4 | - | - | - | - | 16.4 |
| Co-products | - | - | - | 0 | - | 0.0 |
| Variable OPEX | - | 0.6 | 32.5 | 2.5 | 5.3 | 40.8 |
| Fixed OPEX | - | 1.0 | - | 0.6 | 1.7 | 3.3 |
| Levelised CAPEX | - | 2.1 | - | 0.4 | 18.3 | 20.7 |
| Total | 16.4 | 3.7 | 32.5 | 3.5 | 25.3 | 81.3 |

Figure 6.5 shows the component breakdown of the Chain 5 optimum case net chain LCOE – overall, the total LCOE has fallen 34% from the base case. Comparing this chart with the base case (Figure 4.10), the most important component to the net chain LCOE is no longer the conversion unit, but is now the transport component. This is due to the significant decrease in the CFB combustion boiler costs, particularly the levelised CAPEX. The conversion and transport components still remain the main contributors to chain LCOE, with the storage and pre-processing costs relatively insignificant. The costs of all of the upstream components (including transport) have also fallen slightly due to higher chain efficiency.

6.3.6 Chain 6 – CFB combustion boiler with pelleting

The results for the optimised case in Chain 6 are presented below. For this chain, a total of 22 parameters were optimised.

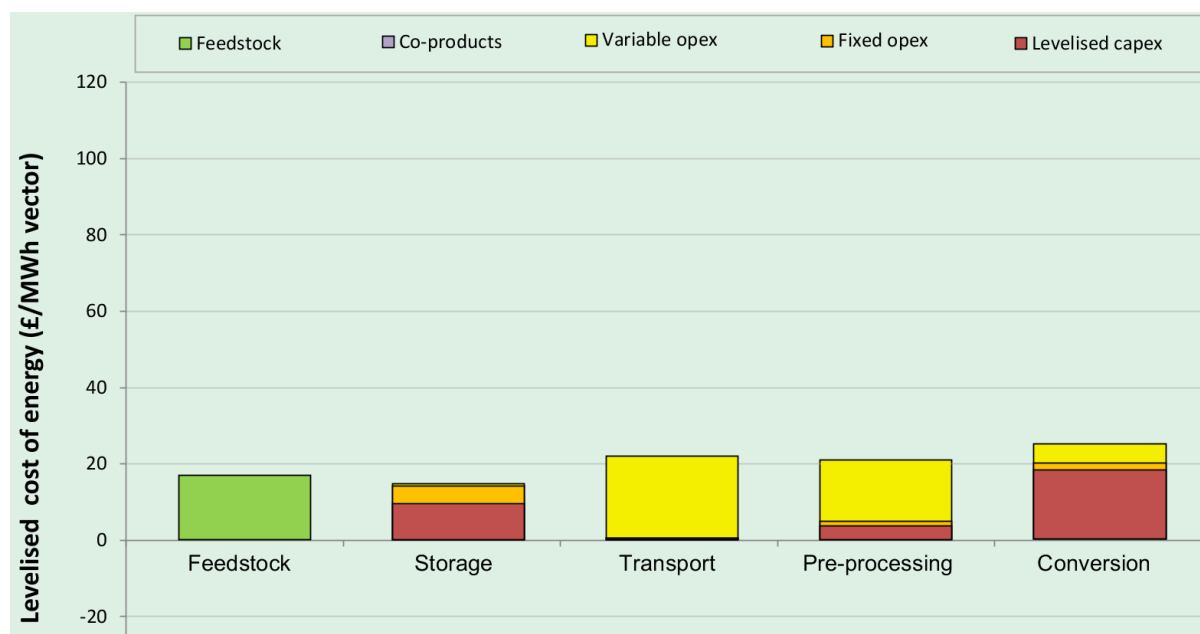

Figure 6.6: Chain 6 optimum case LCOE component breakdown

Table 6.6: Chain 6 optimum case LCOE component breakdown

| Costs (£/MWh _e) | Feedstock | Storage | Transport | Pre-processing | CFB combustion | Total |
|-----------------------------|-------------|-------------|-------------|----------------|----------------|-------------|
| | | | | Pelleting | | |
| Feedstock | 16.4 | - | - | - | - | 16.4 |
| Co-products | - | - | - | 0 | - | 0.0 |
| Variable OPEX | - | 0.4 | 21.7 | 16.1 | 5.1 | 43.4 |
| Fixed OPEX | - | 4.5 | - | 1.3 | 1.7 | 7.5 |
| Levelised CAPEX | - | 9.6 | - | 3.3 | 17.9 | 30.7 |
| Total | 16.4 | 14.5 | 21.7 | 20.7 | 24.7 | 98.1 |

Figure 6.6 shows the component breakdown of the Chain 6 optimum case net chain LCOE – overall, the total LCOE has fallen 32% from the base case. Compared to the base case (Figure 4.12), there is no longer any dominant component, as the costs are very well distributed throughout the chain. This is due to significant decreases in the conversion costs (mainly the levelised CAPEX), and modest reductions in the pre-processing costs (particularly the variable OPEX). There are also smaller decreases in feedstock, storage and transport component costs, due to chain efficiency improvements.

6.3.7 Chain 7 – CFB combustion boiler with chemical washing and pelleting

The results for the optimised case in Chain 7 are presented below. For this chain, a total of 34 parameters were optimised.

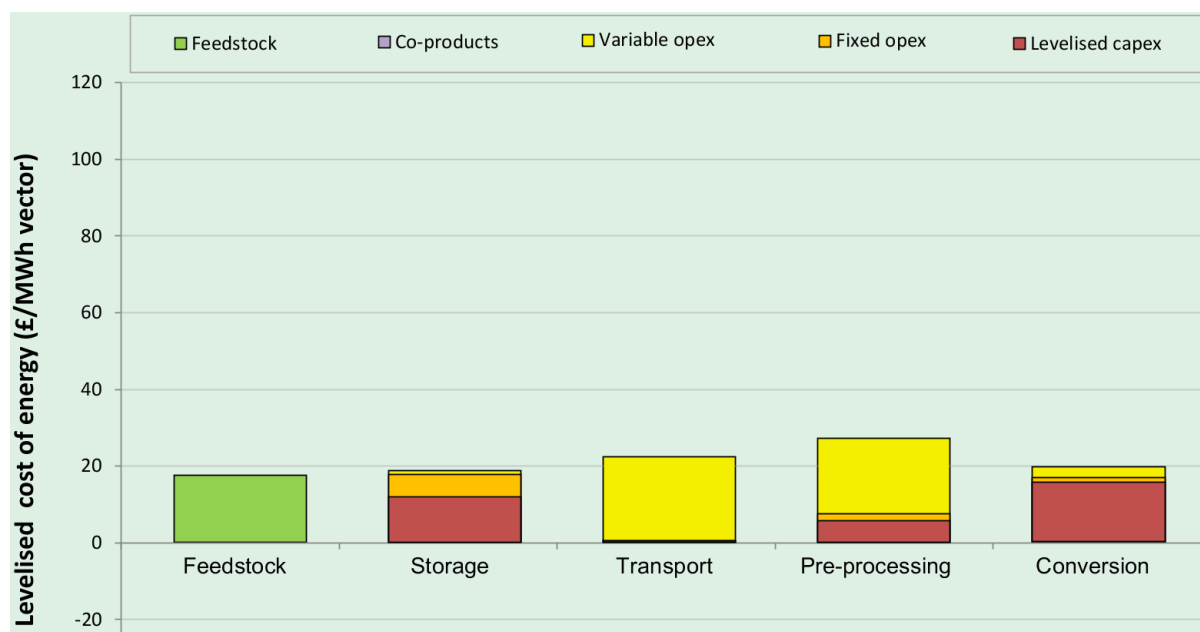

Figure 6.7: Chain 7 optimum case LCOE component breakdown

Table 6.7: Chain 7 optimum case LCOE component breakdown

| Costs (£/MWh _e) | Feedstock | Storage | Transport | Pre-processing | | CFB combustion | Total |
|-----------------------------|-------------|-------------|-------------|----------------|-------------|----------------|--------------|
| | | | | Chemical wash | Pelleting | | |
| Feedstock | 17.2 | - | - | - | - | - | 17.2 |
| Co-products | - | - | - | 0 | 0 | - | 0.0 |
| Variable OPEX | - | 0.7 | 22.1 | 6.5 | 13.2 | 2.7 | 45.3 |
| Fixed OPEX | - | 5.7 | - | 0.8 | 1.3 | 1.4 | 9.1 |
| Levelised CAPEX | - | 12.0 | - | 1.9 | 3.3 | 15.1 | 32.3 |
| Total | 17.2 | 18.4 | 22.1 | 9.3 | 17.7 | 19.2 | 103.9 |

Figure 6.7 shows the component breakdown of the Chain 7 optimum case net chain LCOE – overall, the total LCOE has fallen 37% from the base case. Similar to Chain 6, this optimised case for Chain 7 has a fairly even spread of costs throughout the chain components. Comparing Figure 6.7 with the base case component breakdown (Figure 4.14), in the optimised case there is a reduction in the conversion and pre-processing costs that bring them closer to the cost of the other LCOE components - although the pre-processing unit remains the largest contributor to the LCOE costs. As in Chain 6, this is mainly achieved through a significant reduction in the conversion unit’s levelised CAPEX and reductions in the pre-processing unit’s variable OPEX. There are also small decreases in feedstock, storage and transport component costs, due to chain efficiency improvements.

6.3.8 Chain 8 – EF gasifier + syngas CCGT with pelleting

The results for the optimised case in Chain 8 are presented below. For this chain, a total of 32 parameters were optimised.

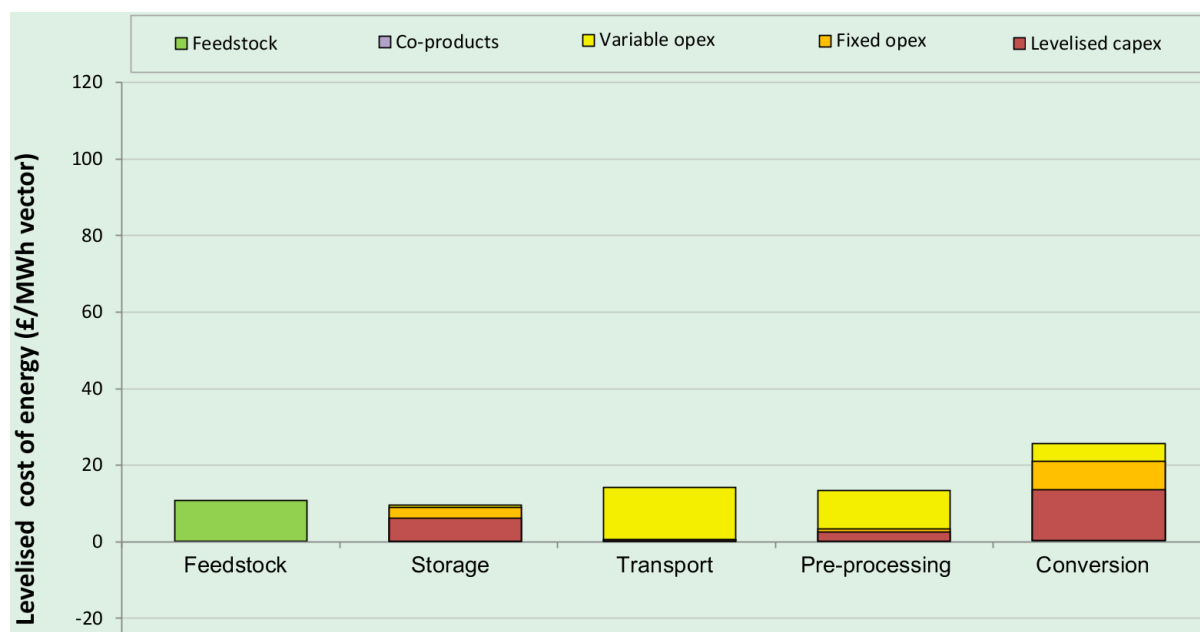

Figure 6.8: Chain 8 optimum case LCOE component breakdown

Table 6.8: Chain 8 optimum case LCOE component breakdown

| Costs (£/MWh _e) | Feedstock | Storage | Transport | Pre-processing | EF gasifier + syngas CCGT | Total |
|-----------------------------|-------------|------------|-------------|----------------|---------------------------|-------------|
| | | | | Pelleting | | |
| Feedstock | 10.4 | - | - | - | - | 10.4 |
| Co-products | - | - | - | 0 | - | 0.0 |
| Variable OPEX | - | 0.2 | 13.7 | 10.2 | 4.6 | 28.8 |
| Fixed OPEX | - | 2.8 | - | 0.8 | 7.3 | 11.0 |
| Levelised CAPEX | - | 6.0 | - | 2.1 | 13.0 | 21.2 |
| Total | 10.4 | 9.1 | 13.7 | 13.1 | 25.0 | 71.3 |

Figure 6.8 shows the component breakdown of the Chain 8 optimum case net chain LCOE – overall, the total LCOE has fallen 43% from the base case. Comparing to the base case (Figure 4.16), there is a considerable reduction in the conversion and pre-processing costs (54% and 44% respectively), although the EF gasifier + CCGT conversion costs remain the largest contributor to the LCOE. The other chain costs (feedstock, storage, transport) were already relatively small in the base case, and are now smaller still given the chain efficiency increases.

6.3.9 Chain 9 – EF gasifier + syngas CCGT with torrefaction + pelleting

The results for the optimised case in Chain 9 are presented below. For this chain, a total of 34 parameters were optimised.

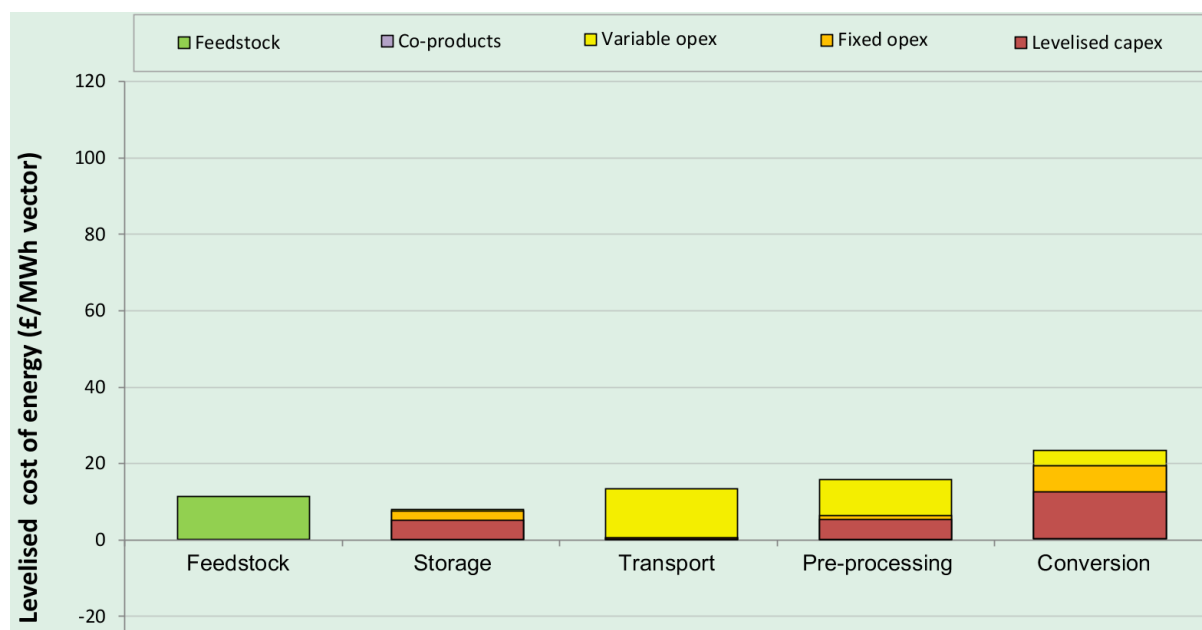

Figure 6.9: Chain 9 optimum case LCOE component breakdown

Table 6.9: Chain 9 optimum case LCOE component breakdown

| Costs (£/MWh _e) | Feedstock | Storage | Transport | Pre-processing | | EF gasifier + syngas CCGT | Total |
|-----------------------------|-------------|------------|-------------|--------------------------|-------------|---------------------------|-------------|
| | | | | Torrefaction + pelleting | | | |
| Feedstock | 10.8 | - | - | - | - | - | 10.8 |
| Co-products | - | - | - | 0 | - | - | 0.0 |
| Variable OPEX | - | 0.3 | 13.0 | 9.6 | 4.0 | - | 26.9 |
| Fixed OPEX | - | 2.4 | - | 1.1 | 6.8 | - | 10.3 |
| Levelised CAPEX | - | 5.0 | - | 4.9 | 11.9 | - | 21.8 |
| Total | 10.8 | 7.6 | 13.0 | 15.6 | 22.8 | - | 69.8 |

Figure 6.9 shows the component breakdown of the Chain 9 optimum case net chain LCOE – overall, the total LCOE has fallen 47% from the base case. Comparing Figure 6.9 with the LCOE breakdown for the base case (Figure 4.18), the main reduction in the LCOE costs from the base to the optimised case is due to a reduction in the conversion and pre-processing costs, especially the conversion technology’s levelised CAPEX and the pre-processing technology’s variable OPEX (which were two of the largest costs in the base case). The conversion technology is still the largest component of the LCOE, despite a reduction of 55% from the base case. There is also a reduction in the feedstock, storage and transport costs due to the increase in chain efficiency (which decreases the amount of required feedstock).

6.3.10 Chain 10 – EF gasifier + syngas CCGT with pyrolysis

The results for the optimised case in Chain 10 are presented below. For this chain, a total of 40 parameters were optimised.

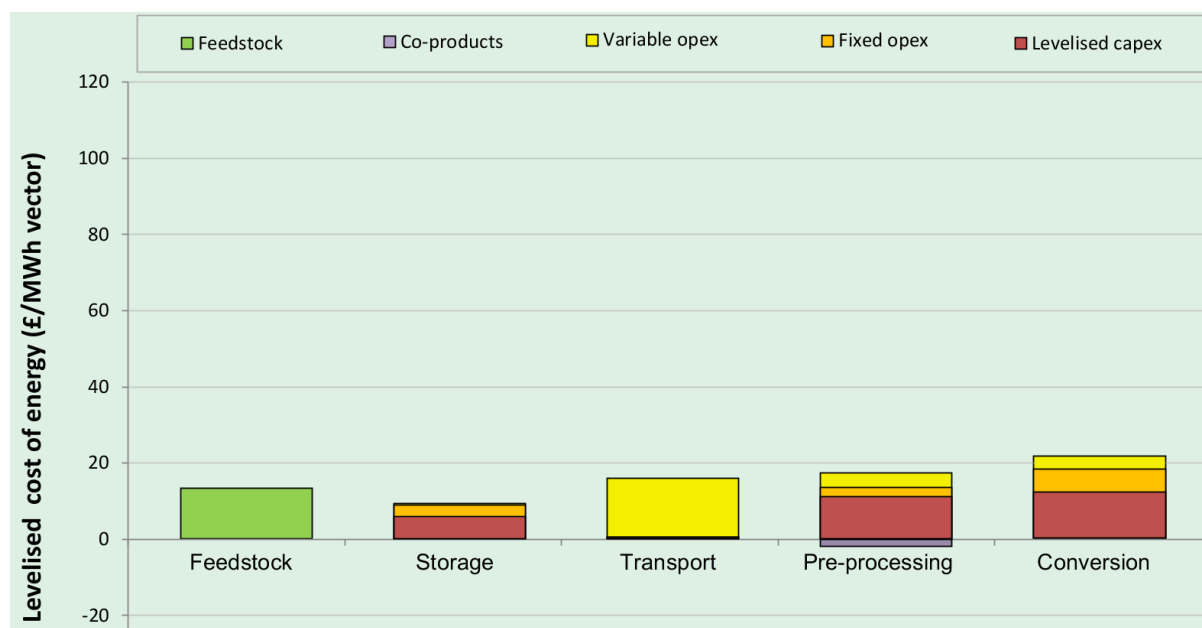

Figure 6.10: Chain 10 optimum case LCOE component breakdown

Table 6.10: Chain 10 optimum case LCOE component breakdown

| Costs (£/MWh _e) | Feedstock | Storage | Transport | Pre-processing | EF gasifier + syngas CCGT | Total |
|-----------------------------|-------------|------------|-------------|----------------|---------------------------|-------------|
| | | | | Pyrolysis | | |
| Feedstock | 12.9 | - | - | - | - | 12.9 |
| Co-products | - | - | - | -1.9 | - | -1.9 |
| Variable OPEX | - | 0.3 | 15.7 | 3.9 | 3.3 | 23.2 |
| Fixed OPEX | - | 2.8 | - | 2.4 | 6.2 | 11.4 |
| Levelised CAPEX | - | 5.9 | - | 10.8 | 11.7 | 28.4 |
| Total | 12.9 | 9.0 | 15.7 | 15.2 | 21.2 | 74.0 |

Figure 6.10 shows the component breakdown of the Chain 10 optimum case net chain LCOE – overall, the total LCOE has fallen 59% from the base case. Comparing with the base case results (Figure 4.20), the main contributor to the LCOE is no longer the pre-processing unit (pyrolysis), and now is the conversion unit (EF gasifier + CCGT), although there is now a relatively even spread of costs along the chain. This change is due to the considerable drop in the pre-processing costs of 74%, which is a larger drop than the 61% decrease in the conversion technology costs. There are also fairly significant decreases in feedstock, storage and transport component costs, due to large improvements in the conversion and pre-processing unit efficiencies.

6.4 Summary of optimum case findings

Table 6.11 compares the key output metrics for all ten chains, with the results generated at the optimum case for each chain (i.e. with each of the technical parameters that were allowed vary placed at their optimum value, instead of at their base case value). Note that the analysis below the table applies only to these optimum case results for the chain architectures selected, and may not universally apply across the whole parameter space (e.g. the findings could be different to those at the base case, or were different optimum cases or architectures selected).

Table 6.11: Comparison of optimum case results for the 10 chains

| Chain | LCOE (£/MWh) | Net efficiency (%) | Gross efficiency (%) | GHG emissions (kgCO ₂ e/MWh) |
|--|--------------------|--------------------|----------------------|---|
| 1 - screen, boiler (<i>heat</i>) | 35 _[th] | 95.1 | 97.3 | 19 _[th] |
| 2 - screen, field wash, boiler (<i>heat</i>) | 36 _[th] | 92.2 | 94.9 | 22 _[th] |
| 3 - screen, BFB gasify | 75 _[e] | 40.4 | 42.4 | 41 _[e] |
| 4 - water wash, pellet, BFB gasify | 97 _[e] | 33.4 | 39.2 | 92 _[e] |
| 5 - screen, CFB combust | 81 _[e] | 32.7 | 37.4 | 69 _[e] |
| 6 - pellet, CFB combust | 98 _[e] | 30.1 | 37.4 | 110 _[e] |
| 7 - chem wash, pellet, CFB combust | 104 _[e] | 28.4 | 35.8 | 128 _[e] |
| 8 - pellet, EF gasify | 71 _[e] | 50.3 | 57.1 | 68 _[e] |
| 9 - torr+pellet, EF gasify | 70 _[e] | 48.4 | 54.5 | 68 _[e] |
| 10 - pyrolysis, EF gasify | 74 _[e] | 44.5 | 48.0 | 24 _[e] |

Comparing the Chain 1 and 2 results, the optimised Chain 2 remains more expensive compared to Chain 1, despite the difference being reduced to £1/MWh_{th}. Chain 2 still has higher GHG emissions (due to the field wash requirements) as well as lower efficiency than Chain 1 (due to the decrease in LHV caused by the gain in moisture in the washing process and the extra electricity demands of the field washing). Overall, despite the difference in price and emissions for Chain 2 and Chain 1 being closer, adding the field washing step does not reduce the overall conversion costs to compensate choosing Chain 2 over Chain 1.

For the chains which use the BFB gasifier and syngas engine conversion technology (Chains 3 and 4), both chains have a similar LCOE decrease from the base case to the optimal case (97 £/MWh_e and 100£/MWh_e respectively for Chains 3 and 4). Despite the slightly higher drop in LCOE for Chain 4, Chain 3 remains the cheapest chain, meaning that even with optimised water washing and pelleting units, the added costs of this pre-processing is still not offset by the drop in the conversion costs. Regarding the efficiencies, Chain 4 still has a lower gross and net efficiency (as to be expected from the lower efficiency of the more complex pre-processing technologies as well as their electricity requirements). Both Chains 3 and 4 have a considerable reduction in the GHG emissions. Chain 4 has the most significant reduction (83 kgCO₂e/MWh); however, since the base case emissions were considerably higher, the GHG emissions for the optimised case are still higher than for Chain 3. The conclusion of the optimisation for the BFB gasifier chains is that despite considerable improvements in Chain 4, Chain 3 remains the cheaper chain with the lower GHG emissions.

For the chains which use the CFB combustion conversion technology (Chains 5-7), the messages for the base and optimal cases do not differ significantly, as adding complexity to the pre-processing does not reduce the conversion costs sufficiently enough to offset the increase in the pre-processing

costs. This means that Chain 5 remains the cheapest chain, while Chain 7 is the most expensive. The change in efficiencies between the base cases and optimal cases is approximately the same for the three chains (around 6.5% for the net efficiency and 5.6% for the gross efficiency), which suggest that the optimisation of the pre-processing units have little influence on the gross efficiency, compared to optimisation of the conversion unit. Looking at the GHG emissions for Chains 5-7, the chains with the more complex pre-processing technologies have the largest drop in GHG emissions. Despite this, as for the base case, Chain 5 still has the lowest GHG emissions out of Chains 5-7, while Chain 7 still has the highest GHG emissions (of all the optimised TEABPP chains).

Comparing the optimised group of chains which use an EF gasifier and CCGT turbine conversion unit (Chains 8-10), Chain 9 is now the cheapest chain, followed by Chain 8, and Chain 10 is the most expensive chain. This is a change from the base case, where Chain 8 had the lowest LCOE. This change in order is due to a drop in the torrefaction and pelleting costs, and an increase in torrefied pellet LHV, for Chain 9. Looking at the efficiencies for these chains, Chain 8 remains the most efficient chain, followed by Chain 9 and Chain 10 being the least efficient. Despite this, the chain with the largest increase in efficiency from its base case in this group is Chain 10, followed by Chain 9. Between Chains 8-10, Chain 10 still has the lowest GHG emissions, due to the pyrolysis unit self-sufficiency. However, Chain 9 now has the same GHG emissions as Chain 8, suggesting that the modest additional GHG emissions associated with adding torrefaction compared to only pelleting in the base case can be overcome with innovation.

Finally, looking at the chains as a whole, for heat production, Chain 1 remains the best option compared to Chain 2, across all the metrics. Looking at only the chains which produce electricity, Chain 5 is no longer the cheapest chain, being replaced by Chain 9, with a LCOE of 70 £/MWh. The most efficient chain is Chain 8, with a net efficiency of 50.3%, and the chain with the lowest GHG emissions is Chain 10, with only 24 kgCO_{2e}/MWh.

6.5 Impact of innovation

Focusing on only the technical parameters as selected in Section 6.1, and using automated input procedures within gPROMS, PSE have assessed which changes in key technical conversion and pre-processing parameters give the largest improvements in LCOE, performance and emissions for each chain. This sub-section therefore shows what impact technical innovation can have on each of the chains⁴¹.

Results are presented in a series of tables that contains rows with the key input parameters, and columns showing the new optimal metric value, and the % change in output LCOE, efficiency and emissions from the base case when the parameter is individually moved to its optimal value from its base case value. Note that the % change in each metric is calculated relative to the base case value, and for the net efficiency is not the absolute change in %-points from the base case. In general, the %s in each of these innovation tables cannot be added, because as soon as one improvement is made in one parameter, this reduces the potential innovation impact for other parameters.

⁴¹ It was not in scope of the TEABPP project to work backwards from the conversion technology biomass specification limits to calculate, for each feedstock, the required pre-processing types and innovation opportunities. Furthermore, this approach is less valuable given the large uncertainties around the warning flag limits, plus the spread of starting feedstock compositions and pre-processing effectiveness.

These tables are ranked by % change in LCOE. Only the most important technical parameters are shown in the following tables, with a top 3 for each metric or >1% change threshold applied to select which parameters to display. When 0% change is given, the actual % might be rounded down to 0%.

After each table and discussion of the results, there is a section for each chain on the technical targets that would be required to meet these optimum parameter values. The less ambitious end of the targets indicates what might be possible in the near-term given today's uncertainties. This would have to be based on very careful selection between manufacturers, given there is a wide range of costs and efficiencies (and usage rates of energy and materials) associated with the technologies, and the base case values generally sit in the middle of the current industry ranges. The more ambitious end of the targets indicate what might be possible in the future, based on the technical innovation descriptions given in the target bullets – and if these more ambitious targets were met, the chain would achieve the modelled optimum case values for each parameter.

6.5.1 Chain 1 – Underfeed stoker combustion boiler with screening

As a reminder, the base values for Chain 1 were LCOE = £53/MWh_{th}, net efficiency = 78.9%, GHG emissions = 33 kgCO₂e/MWh_{th}. The optimum values (when optimising all the allowed technical parameters together) are LCOE = £35/MWh_{th}, net efficiency = 95.1%, GHG emissions = 19 kgCO₂e/MWh_{th}.

Bearing in mind this context, Table 6.12 provides a summary of the key innovations that improve Chain 1, when each parameter is varied individually. A total of 16 parameters were analysed, of which only the most important 8 are shown.

Table 6.12: Key technical innovation parameters within Chain 1

| Input parameter to be optimised (individually) | LCOE when optimised (£/MWh _{th}) | Change in LCOE from base case | Net efficiency when optimised | Change in net efficiency from base case | GHG emissions when optimised (kgCO ₂ e/MWh _{th}) | Change in GHG emissions from base case |
|---|--|-------------------------------|-------------------------------|---|---|--|
| Underfeed stoker total installed CAPEX multiplier | 46 | 15% | 78.9% | 0% | 33 | 0% |
| Underfeed stoker efficiency multiplier | 47 | 12% | 90.1% | 14% | 31 | 7% |
| Underfeed stoker input electricity multiplier | 51 | 4% | 80.7% | 2% | 22 | 34% |
| Underfeed stoker lifetime | 51 | 4% | 78.9% | 0% | 33 | 0% |
| Miscanthus chips storage time | 52 | 2% | 80.4% | 2% | 33 | 1% |
| Woody chips storage time | 53 | 1% | 79.5% | 1% | 33 | 0% |
| Woody screening input diesel multiplier | 53 | 0% | 79.0% | 0% | 33 | 2% |
| Miscanthus screening input diesel multiplier | 53 | 0% | 78.9% | 0% | 33 | 1% |

This shows that optimising the CAPEX for the underfeed stoker has the largest improvement in LCOE, improving the underfeed stoker's efficiency has the largest improvement in net efficiency, and

minimising the electricity input in the underfeed stoker has the largest improvement in GHG emissions.

The base case results (Figure 4.2) show that the CAPEX for the underfeed stoker is the largest cost of the chain. Thus, it is no surprise that the biggest contributor to the drop in LCOE from the base case to the optimised case is the multiplier parameter for the CAPEX. Optimisation in the boiler CAPEX can reduce the total LCOE by 15%. Optimisation in the underfeed stoker efficiency multiplier also drives the LCOE down by 12%, so is a significant contributor.

Looking at the net efficiency, the screening process has very low losses, so the biggest loss of efficiency in Chain 1 is the conversion process, so the efficiency multiplier should be the largest contributor to the increase in efficiency. With higher efficiency in the boiler, the feedstock requirements fall, and consequently the overall net efficiency increases.

The electricity input for the underfeed stoker for the base case accounts for 45% (or 15 kgCO₂e/MWh_{th}) of the total Chain 1 GHG emissions. Hence, it should be expected that a reduction in the energy input multiplier leads to a considerable reduction of the total GHG emissions.

So, in summary, the largest innovation improvements can be achieved by targeting:

- A 15-30% fall in underfeed stoker boiler CAPEX. This relies on design improvements to reduce steel use and electronics costs, and reduced installation costs (including reduced profit margins) with the ramp-up to hundreds of thousands of units per year installed globally.
- A 10-14% increase in underfeed stoker boiler efficiency. This relies on improvements in heat transfer within the boiler design, and use of condensing boiler technology (which B&V consider needs to become more commonplace at the large commercial/industrial scales considered).
- A 50-75% fall in electricity consumption by the underfeed stoker boiler. This relies on electronic motor improvements in fans and pumps, and less power required for boiler ignition. Fewer downtime incidents also would reduce re-ignition events.

6.5.2 Chain 2 – Underfeed stoker combustion boiler with screening and field washing

As a reminder, the base values for Chain 2 were LCOE = 57 £/MWh, net efficiency = 76.1%, GHG emissions = 37 kgCO₂e/MWh_{th}. The optimum values (when optimising all the allowed technical parameters together) are LCOE = 36 £/MWh, net efficiency = 92.2%, GHG emissions = 22 kgCO₂e/MWh_{th}. Table 6.13 provides a summary of the key innovations that improve Chain 2. A total of 49 parameters were analysed, of which only the most important 10 are shown.

Table 6.13: Key technical innovation parameters within Chain 2

| Input parameter to be optimised (individually) | LCOE when optimised (£/MWh _{th}) | Change in LCOE from base case | Net efficiency when optimised | Change in net efficiency from base case | GHG emissions when optimised (kgCO ₂ e/MWh _{th}) | Change in GHG emissions from base case |
|---|--|-------------------------------|-------------------------------|---|---|--|
| Underfeed stoker total installed CAPEX multiplier | 49 | 14% | 76.1 | 0% | 37 | 0% |
| Underfeed stoker efficiency multiplier | 50 | 12% | 87.0 | 14% | 34 | 7% |
| Underfeed stoker input electricity multiplier | 55 | 4% | 77.9 | 2% | 26 | 30% |
| Underfeed stoker lifetime | 55 | 4% | 76.1 | 0% | 37 | 0% |
| Underfeed stoker fixed OPEX parts multiplier | 56 | 1% | 76.1 | 0% | 37 | 0% |
| Miscanthus chips storage time | 56 | 1% | 77.3 | 2% | 37 | 1% |
| Woody field wash moisture gain | 56 | 0% | 76.5 | 1% | 37 | 0% |
| Woody screening input diesel multiplier | 56 | 0% | 76.2 | 0% | 37 | 1.4% |
| Woody field wash input electricity multiplier | 56 | 0% | 76.1 | 0% | 37 | 0.9% |
| Miscanthus screening input diesel multiplier | 57 | 0% | 76.1 | 0.1% | 37 | 1% |

Looking at Table 6.13, the conclusions for Chain 2 are similar than for Chain 1, with optimising the underfeed stoker CAPEX multiplier having the largest improvement in LCOE, improving the underfeed stoker's efficiency multiplier having the largest improvement in net efficiency, and minimising the electricity input in the underfeed stoker has the largest improvement in GHG emissions.

The parameters in the field washing unit have a relatively insignificant impact on the LCOE (<1% change), and only a very small impact on the net efficiency and GHG emissions (of around 1%). So even when optimising the field wash technology, the LCOE and GHG emissions for Chain 1 will remain lower than Chain 2.

So, in summary, the largest innovation improvements for Chain 2 can be achieved with the same targets as given in Chain 1 above.

6.5.3 Chain 3 – BFB gasifier + syngas engine with screening

As a reminder, the base values for Chain 3 were LCOE = 172 £/MWh, net efficiency = 24%, GHG emissions = 87 kgCO₂e/MWh_e. The optimum values (when optimising all the allowed technical parameters together) are LCOE = 75 £/MWh, net efficiency = 40.4%, GHG emissions = 41 kgCO₂e/MWh_e. Table 6.14 provides a summary of the key innovations that improve Chain 3. A total of 27 parameters were analysed, of which only the most important 11 are shown.

Table 6.14: Key technical innovation parameters within Chain 3

| Input parameter to be optimised (individually) | LCOE when optimised (£/MWh _e) | Change in LCOE from base case | Net efficiency when optimised | Change in net efficiency from base case | GHG emissions when optimised (kgCO ₂ e/MWh _e) | Change in GHG emissions from base case |
|--|---|-------------------------------|-------------------------------|---|--|--|
| BFB gasifier total installed CAPEX multiplier | 128 | 25% | 24.0 | 0% | 87 | 0% |
| Syngas engine efficiency multiplier | 154 | 10% | 28.2 | 18% | 76 | 13% |
| BFB gasifier efficiency multiplier | 157 | 8% | 27.3 | 14% | 78 | 11% |
| Syngas clean-up efficiency | 159 | 7% | 27.0 | 13% | 79 | 10% |
| Woody chips storage time | 164 | 4% | 24.8 | 3% | 83 | 4% |
| Syngas clean-up CAPEX multiplier | 165 | 4% | 24.0 | 0% | 87 | 0% |
| Syngas engine total installed CAPEX multiplier | 165 | 4% | 24.0 | 0% | 87 | 0% |
| BFB gasifier input electricity multiplier | 167 | 3% | 25.0 | 4% | 84 | 4% |
| Miscanthus chips storage time | 168 | 2% | 24.4 | 2% | 86 | 1% |
| BFB gasifier variable OPEX labour multiplier | 169 | 2% | 24.0 | 0% | 87 | 0% |
| BFB gasifier input diesel multiplier | 169 | 1% | 25.5 | 6% | 72 | 18% |

This shows that optimising the BFB gasifier CAPEX has the largest improvement in LCOE, improving the syngas engine's efficiency has the largest improvement in net efficiency, and minimising the diesel usage of the BFB gasifier has the largest improvement in GHG emissions.

The BFB gasifier levelised CAPEX costs account for 37% of the total LCOE for the base case, so not surprisingly the biggest contributor to the drop in LCOE is the multiplier parameter for the total installed cost.

The base case results (Figure 4.6) show that the CAPEX for the conversion unit is the largest cost of the chain. Thus, it is no surprise that the biggest contributor to the drop in LCOE from the base case to the optimised case is the multiplier parameter for the CAPEX. Optimisation in the BFB gasifier CAPEX can reduce the total LCOE by 25%, and optimisation in the efficiency multipliers for the three conversion sub-units (BFB gasifier, syngas cleanup and syngas engine) also drives the LCOE down by 8%, 7% and 10% respectively, so are significant contributors.

Looking at the net efficiency, as discussed for Chain 1, the screening process has very low losses, so the biggest loss of efficiency in Chain 3 is the conversion process. Thus, it is to be expected that improvements in the different conversion sub-units will lead to the largest increases in efficiency. Optimisation in the efficiency multipliers for the BFB gasifier, syngas cleanup and syngas engine are

individually able to improve the net efficiency by 14%, 13% and 18% respectively⁴², so combined will have a significant impact.

The largest reduction for the GHG emissions can be found in reducing the BFB gasifier input diesel multiplier, which for the base case produces 21 kgCO₂e/MWh_e, accounting for 24% of Chain 3 base case GHG emissions. Combined, the conversion sub-unit efficiencies will also have a strong impact. The BFB gasifier electricity input multiplier has a modest impact on chain GHG emissions, as this power requirement is met by the syngas engine (as a parasitic load), slightly reducing net chain efficiency, but not introducing high GHG intensity power imports (as in Chains 1 and 2).

So, in summary, the largest innovation improvements can be achieved by targeting:

- A 30-50% fall in BFB gasifier CAPEX. This relies on cost engineering and design improvements to reduce steel use and biomass handling costs, and reduced installation costs (including reduced EPC profit margins) as the technology is further de-risked and with the ramp-up to hundreds of units per year installed globally.
- A 10-12% increase in BFB gasifier efficiency. This relies on improvements in energy integration between the conversion plant components, particularly for any feedstock drying and steam (or oxygen) generation requirements. Novel gasifier bed catalysts can also overcome ash content problems.
- A 10% increase in syngas cleanup efficiency. This relies on avoiding large temperature and pressure changes across the various cleanup steps, for example through using hot syngas tar removal. Various options are discussed in the TEABPP D1 report.
- A 10-14% increase in syngas engine efficiency. This relies on design optimisation of the engine configuration for biomass-derived syngas (high in hydrogen), and advanced controls to handle varying syngas compositions (particularly the H₂:CO ratio).
- A 30-50% fall in electricity consumption by the BFB gasifier. This relies on improvements in the parasitic loads of fans & pumps, and reduced ignition requirements (including fewer downtime events).
- A 50-75% fall in diesel consumption by the BFB gasifier. This relies on improved gasification conditions, plus less cycling and fewer start-ups (including fewer downtime incidents).

6.5.4 Chain 4 – BFB gasifier + syngas engine with water washing and pelleting

As a reminder, the base values for Chain 4 were LCOE = 197 £/MWh, net efficiency = 18.1%, GHG emissions = 175 kgCO₂e/MWh_e. The optimum values (when optimising all the allowed technical parameters together) are LCOE = 97 £/MWh, net efficiency = 33.4%, GHG emissions = 92 kgCO₂e/MWh_e. Table 6.15 provides a summary of the key innovations that improve Chain 4. A total of 48 parameters were analysed, of which only the most important 13 are shown.

⁴² Note that these are independent improvements from the base case, and not strictly additive – their combined impact is less than a 45% improvement from the base case. In general, the %s in each of these innovation tables cannot be added, because as soon as one improvement is made in one parameter, this reduces the potential innovation impact for other parameters.

Table 6.15: Key technical innovation parameters within Chain 4

| Input parameter to be optimised (individually) | LCOE when optimised (£/MWh _e) | Change in LCOE from base case | Net efficiency when optimised | Change in net efficiency from base case | GHG emissions when optimised (kgCO ₂ e/MWh _e) | Change in GHG emissions from base case |
|--|---|-------------------------------|-------------------------------|---|--|--|
| BFB gasifier total installed CAPEX multiplier | 164 | 17% | 18.1 | 0% | 175 | 0% |
| Syngas engine efficiency multiplier | 176 | 11% | 22.0 | 22% | 152 | 13% |
| BFB gasifier efficiency multiplier | 179 | 9% | 21.2 | 17% | 157 | 11% |
| Syngas clean-up efficiency | 181 | 8% | 20.9 | 15% | 158 | 10% |
| Syngas engine total installed CAPEX multiplier | 191 | 3% | 18.1 | 0% | 175 | 0% |
| Syngas clean-up CAPEX multiplier | 193 | 2% | 18.1 | 0% | 175 | 0% |
| Pelleting input pellet binder multiplier | 193 | 2% | 18.1 | 0% | 170 | 3% |
| BFB gasifier input electricity multiplier | 193 | 2% | 19.1 | 5% | 169 | 4% |
| BFB gasifier input diesel multiplier | 194 | 1% | 19.5 | 8% | 160 | 9% |
| Water washing minimum moisture content | 195 | 1% | 18.4 | 2% | 175 | 0% |
| Pelleting input electricity multiplier | 196 | 1% | 18.5 | 2% | 168 | 4% |
| BFB gasifier input urea multiplier | 196 | 0% | 18.1 | 0% | 171 | 3% |
| Pelleting input diesel multiplier | 196 | 0% | 18.4 | 2% | 172 | 2% |

Comparing the innovation improvements for Chains 3 and 4 (Table 6.14 and Table 6.15 respectively), the parameters with the greatest potential for LCOE improvements (BFB gasifier CAPEX) and net efficiency innovation (syngas engine efficiency) are the same. The only change is the ranking for the GHG emissions, where the largest improvements are now also due to the syngas engine efficiency.

For Chain 4, improvements in BFB gasifier CAPEX reduce the LCOE only by £33/MWh_e (17%) from the base case, compared to a £44/MWh_e (25%) reduction for Chain 3. This is in part because the levelised CAPEX costs are already lower in Chain 4, as the levelised CAPEX costs depend on availability and conversion plant efficiency, which are both higher for cleaner feedstocks. However, these BFB gasifier CAPEX costs still remain the main contribution to the total LCOE.

Regarding the overall net efficiency savings, the % gains in efficiency from improved conversion sub-unit efficiency multipliers are slightly higher than in Chain 3, due to the lower net chain efficiency of Chain 4. The higher GHG emissions of Chain 4 also explain why the diesel input multiplier in Chain 4 is now relatively less important than the conversion efficiency multipliers, which impact the higher upstream GHG emissions in water washing and pelleting.

Looking at the possible optimisation of the pre-processing parameters, avoiding all use of pelleting binder (or substitution of starch by a free waste material) could reducing the LCOE by 2% and GHG

emissions by 3%. However, it should be noted that optimisation of this parameter and other pre-processing parameters (e.g. pellet plant CAPEX and water washing CAPEX) are not enough to get the Chain 4 LCOE or GHG emissions to the same level as Chain 3, as their impact is very limited.

So, in summary, the largest innovation improvements for Chain 4 can be achieved with the same targets as given in Chain 3 above.

6.5.5 Chain 5 – CFB combustion boiler with screening

As a reminder, the base values for Chain 5 were LCOE = 123 £/MWh, net efficiency = 26.3%, GHG emissions = 89 kgCO₂e/MWh_e. The optimum values (when optimising all the allowed technical parameters together) are LCOE = 81 £/MWh, net efficiency = 32.7%, GHG emissions = 69 kgCO₂e/MWh_e. Table 6.16 provides a summary of the key innovations that improve Chain 5. A total of 21 parameters were analysed, of which only the most important 9 are shown.

Table 6.16: Key technical innovation parameters within Chain 5

| Input parameter to be optimised (individually) | LCOE when optimised (£/MWh _e) | Change in LCOE from base case | Net efficiency when optimised | Change in net efficiency from base case | GHG emissions when optimised (kgCO ₂ e/MWh _e) | Change in GHG emissions from base case |
|---|---|-------------------------------|-------------------------------|---|--|--|
| CFB combustion total installed CAPEX multiplier | 103 | 16% | 26.3 | 0% | 89 | 0% |
| CFB combustion efficiency multiplier | 110 | 10% | 30.4 | 16% | 79 | 11% |
| CFB combustion lifetime | 119 | 3% | 26.3 | 0% | 89 | 0% |
| Warehouse storage time | 120 | 3% | 26.7 | 2% | 88 | 1% |
| Miscanthus chips storage time | 122 | 1% | 26.6 | 1% | 88 | 0% |
| Woody chips storage time | 122 | 0% | 26.6 | 1% | 88 | 1% |
| CFB combustion input diesel multiplier | 123 | 0% | 26.7 | 2% | 85 | 4% |
| Screening input diesel multiplier | 123 | 0% | 26.6 | 1% | 86 | 3% |
| CFB combustion input urea multiplier | 123 | 0% | 26.3 | 0% | 87 | 2% |

This shows that optimising the CAPEX for the CFB combustion plant has the largest improvement in LCOE, whereas improving the CFB combustor's efficiency multiplier has the largest improvement in net efficiency and GHG emissions.

From the base case results (Figure 4.10), the CAPEX for the CFB combustion plant is the largest cost of the chain (with transport costs just behind). Optimisation in the CFB combustion CAPEX can reduce the total LCOE by 16%, and efficiency improvements can achieve a 10% reduction in LCOE. A 3% saving in LCOE can be achieved by optimising the warehouse storage time (to 4 instead of 20 weeks).

As for Chains 1 and 3, since the screening process has a very high efficiency, the loss of efficiency in Chain 5 is mainly due to the CFB combustion. Thus, it is to be expected that an improvement in the CFB efficiency would lead to the highest increase in the overall chain efficiency.

The CFB combustion efficiency multiplier is also the parameter which leads to the largest decrease in the GHG emissions, due to reduction in the required volumes of feedstock and number of trucks, which decreases the GHG emissions. The required diesel in the CFB combustion boiler (for start-up) also has a modest contribution to the GHG emission innovation potentials.

So, in summary, the largest innovation improvements can be achieved by targeting:

- A 20-45% fall in CFB combustion plant CAPEX. This relies on cost engineering and design improvements to reduce steel use and biomass handling costs, and reduced installation costs (including reduced EPC profit margins) with the ramp-up to dozens or hundreds of units per year installed globally. Design improvements⁴³ could include higher pressures for once-through supercritical steam generating capability, particularly at smaller plant scales.
- A 10-13% increase in CFB combustion plant efficiency. This relies on reductions in the parasitic power demands for the primary fluidising air fans as well as fluidised air blowers for loop seal operation, the use of steam- or water-cooled cyclones (instead of air-cooled), plus the use of fluidised bed ash extractors to reduce heat losses. Design changes could include higher steam temperatures⁴⁴ (achieved through more sophisticated alloys or other new materials, with innovation efforts to reduce the added cost), and reheat for steam cycle heat rate improvement.

6.5.6 Chain 6 – CFB combustion boiler with pelleting

As a reminder, the base values for Chain 6 were LCOE = 144 £/MWh, net efficiency = 23.4%, GHG emissions = 147 kgCO₂e/MWh_e. The optimum values (when optimising all the allowed technical parameters together) are LCOE = 98 £/MWh, net efficiency = 30.1%, GHG emissions = 110 kgCO₂e/MWh_e. Table 6.17 provides a summary of the key innovations that improve Chain 6. A total of 22 parameters were analysed, of which only the most important 9 are shown.

⁴³ Other design improvements such as increasing the number of fuel feed points and inert bed feed points will likely not reduce plant CAPEX, but could increase plant availability and lower opex, due to improved bed control (with more homogeneous temperatures and improved flow conditions). However, opex and availability innovation activities were found to be less important than CAPEX innovations.

⁴⁴ Note that if cleaner feedstocks were the primary driver of CFB combustion plant efficiency, we would have found several of the biomass composition parameters amongst the most sensitive parameters in Section 4.5.5. This identified innovation opportunity is therefore focused only on conversion plant changes, and not biomass changes through e.g. pre-processing. Note also that the TEABPP does not parameterise a correlation between CAPEX and efficiency, given that TEABPP uses representative base case plant data, and did not assess correlations across a suite of supplier offerings (e.g. CAPEX and efficiency data on multiple types of CFB combustion plants were not available given the time and budget for data collection) – this topic is instead addressed by the use of uncertainty ranges.

Table 6.17: Key technical innovation parameters within Chain 6

| Input parameter to be optimised (individually) | LCOE when optimised (£/MWh _e) | Change in LCOE from base case | Net efficiency when optimised | Change in net efficiency from base case | GHG emissions when optimised (kgCO ₂ e/MWh _e) | Change in GHG emissions from base case |
|---|---|-------------------------------|-------------------------------|---|--|--|
| CFB combustion total installed CAPEX multiplier | 125 | 13% | 23.4 | 0% | 147 | 0% |
| CFB combustion efficiency multiplier | 129 | 10% | 27.5 | 18% | 130 | 11% |
| CFB combustion lifetime | 140 | 3% | 23.4 | 0% | 147 | 0% |
| Pelleting input pellet binder multiplier | 141 | 2% | 23.4 | 0% | 142 | 3% |
| Miscanthus chips storage time | 143 | 1% | 23.8 | 2% | 146 | 0% |
| Woody chips storage time | 143 | 1% | 24.2 | 4% | 144 | 1% |
| Pelleting input electricity multiplier | 143 | 1% | 23.8 | 2% | 140 | 4% |
| CFB combustion input diesel multiplier | 144 | 0% | 23.8 | 2% | 143 | 2% |
| Pelleting input diesel multiplier | 144 | 0% | 23.7 | 1% | 144 | 2% |

Comparing Table 6.16 and Table 6.17, the conclusions for Chains 6 and 5 are very similar, with optimisation of the CFB combustion CAPEX having the largest improvement in LCOE, and improved CFB efficiencies having the largest improvement in net efficiency and GHG emissions (and a significant impact on LCOE).

A 4% improvement in net efficiency can be achieved by optimising the woody chips storage time (to 106 instead of 78 weeks). Amongst the pre-processing parameters, the pelleting binder input results in the largest reductions in the LCOE, decreasing it by 2% if binder costs are avoided entirely. A reduction in the pelleting input electricity can also reduce GHG emissions by 4%. Other pre-processing changes such as improvements in pelleting CAPEX or fixed OPEX are not significant enough to be included in the table above (i.e. <1% impact). However, as shown in Table 6.11, even combined these pre-processing changes are still not enough to make Chain 6 cheaper than Chain 5.

So, in summary, the largest innovation improvements for Chain 6 can be achieved with the same targets as given in Chain 5 above.

6.5.7 Chain 7 – CFB combustion boiler with chemical washing and pelleting

As a reminder, the base values for Chain 7 were LCOE = 164 £/MWh, net efficiency = 22.0%, GHG emissions = 199 kgCO₂e/MWh_e. The optimum values (when optimising all the allowed technical parameters together) are LCOE = 104 £/MWh, net efficiency = 28.4%, GHG emissions = 128 kgCO₂e/MWh_e. Table 6.18 provides a summary of the key innovations that improve Chain 7. A total of 34 parameters were analysed, of which only the most relevant 14 are shown.

As for Chains 5 and 6, improvements in the CFB plant efficiency have the largest improvement in net efficiency and GHG emissions. Regarding the LCOE, both the CFB combustion CAPEX and the CFB plant efficiency have the largest improvements in LCOE (at 11% each).

Unlike some of the earlier chains, there are a number of pre-processing parameters that make it over the 1% threshold. Amongst those which can contribute to a reduction in the LCOE, the Chemical washing nitrogen content multiplier reduces it the most (by 3%). This multiplier is used to calculate the outlet nitrogen composition of the chemically washed biomass, and lowering (instead of the base case increasing) this nitrogen content can enable the CFB combustion plant to avoid the capital costs of a SNCR. The reduced nitrogen and removal of the SNCR means that there is no longer significant urea use (for NO_x control), which accounts for the fairly significant 8% fall in GHG emissions. Another pre-processing parameter of interest is the ammonium acetate multiplier, whereby if the use of this alkali chemical is minimised, the GHG emissions of Chain 7 fall by 6%. These are both important given Chain 7 has the highest GHG emissions of all the TEABPP chains.

However, as shown in Table 6.11, even the combination of all these pre-processing improvements are not enough to make Chain 7 cheaper than Chains 5 or 6 (when these other chains are also optimised).

Table 6.18: Key technical innovation parameters within Chain 7

| Input parameter to be optimised (individually) | LCOE when optimised (£/MWh _e) | Change in LCOE from base case | Net efficiency when optimised | Change in net efficiency from base case | GHG emissions when optimised (kgCO ₂ e/MWh _e) | Change in GHG emissions from base case |
|--|---|-------------------------------|-------------------------------|---|--|--|
| CFB combustion total installed CAPEX multiplier | 146 | 11% | 22.0 | 0% | 199 | 0% |
| CFB combustion efficiency multiplier | 146 | 11% | 26.0 | 18% | 176 | 11% |
| Chemical washing nitrogen content multiplier | 159 | 3% | 22.0 | 0% | 183 | 8% |
| Chemical washing variable OPEX labour multiplier | 159 | 3% | 22.0 | 0% | 199 | 0% |
| CFB combustion lifetime | 160 | 2% | 22.0 | 0% | 199 | 0% |
| Pelleting input pellet binder multiplier | 160 | 2% | 22.0 | 0% | 194 | 2% |
| Chemical washing total installed CAPEX multiplier | 160 | 2% | 22.0 | 0% | 199 | 0% |
| Chemical washing minimum moisture content | 161 | 2% | 22.6 | 3% | 198 | 1% |
| Pelleting input electricity multiplier | 162 | 1% | 22.4 | 2% | 193 | 3% |
| Chemical washing input ammonium acetate multiplier | 162 | 1% | 22.0 | 0% | 186 | 6% |
| Chemical washing input electricity multiplier | 163 | 0% | 22.3 | 1% | 195 | 2% |
| CFB combustion input diesel multiplier | 163 | 0% | 22.4 | 2% | 196 | 2% |
| Pelleting input diesel multiplier | 163 | 0% | 22.3 | 1% | 196 | 1% |
| CFB combustion input urea multiplier | 163 | 0% | 22.0 | 0% | 196 | 2% |

So, in summary, the largest innovation improvements for Chain 7 can be achieved with the same targets as given in Chain 5 above, with the following additional targets:

- A 25-40% fall in the use of ammonium acetate by the Chemical washing step. This relies on improved mechanical design of the washing steps, process conditions (particle size, temperature, pressure, residence time, pH) being optimised to the TEABPP feedstocks, and improved recycling of any unused chemicals before waste water disposal.
- A 0.55-1.0 target value for the Chemical washing nitrogen content multiplier, i.e. engineering a decrease in biomass nitrogen content. The current base case is 1.79, since the use of ammonium acetate causes a significant increase in nitrogen. Sheffield could envisage an entirely new chemical process that removes some nitrogen, e.g. using new alkali chemicals and/or combining tank reactors. This could also address the first bullet point.

6.5.8 Chain 8 – EF gasifier + syngas CCGT with pelleting

As a reminder, the base values for Chain 8 were LCOE = 124 £/MWh, net efficiency = 29.8%, GHG emissions = 122 kgCO₂e/MWh_e. The optimum values (when optimising all the allowed technical parameters together) are LCOE = 71 £/MWh, net efficiency = 50.3%, GHG emissions = 68 kgCO₂e/MWh_e. Table 6.19 provides a summary of the key innovations that improve Chain 8. A total of 32 parameters were analysed, of which only the most important 14 are shown.

Table 6.19: Key technical innovation parameters within Chain 8

| Input parameter to be optimised (individually) | LCOE when optimised (£/MWh _e) | Change in LCOE from base case | Net efficiency when optimised | Change in net efficiency from base case | GHG emissions when optimised (kgCO ₂ e/MWh _e) | Change in GHG emissions from base case |
|--|---|-------------------------------|-------------------------------|---|--|--|
| CCGT efficiency multiplier | 111 | 11% | 35.9 | 20% | 105 | 14% |
| EF gasifier efficiency multiplier | 113 | 9% | 34.6 | 16% | 108 | 11% |
| EF gasifier total installed CAPEX multiplier | 114 | 8% | 29.8 | 0% | 122 | 0% |
| CCGT total installed CAPEX multiplier | 118 | 5% | 29.8 | 0% | 122 | 0% |
| Syngas clean-up efficiency | 119 | 4% | 31.8 | 7% | 116 | 5% |
| Syngas clean-up CAPEX multiplier | 121 | 2% | 29.8 | 0% | 122 | 0% |
| EF gasifier input electricity multiplier | 121 | 2% | 31.7 | 6% | 116 | 5% |
| Pelleting input pellet binder multiplier | 122 | 2% | 29.8 | 0% | 118 | 3% |
| Miscanthus chips storage time | 123 | 1% | 30.3 | 2% | 122 | 0% |
| EF gasifier input diesel multiplier | 123 | 1% | 30.7 | 3% | 115 | 6% |
| Woody chips storage time | 123 | 1% | 30.8 | 3% | 120 | 1% |
| Pelleting input electricity multiplier | 123 | 1% | 30.2 | 1% | 117 | 4% |
| EF gasifier input urea multiplier | 124 | 0% | 29.8 | 0% | 119 | 3% |
| Pelleting input diesel multiplier | 124 | 0% | 30.1 | 1% | 120 | 2% |

Table 6.19 shows that optimising the CCGT efficiency leads to the largest improvement in LCOE (11%), net efficiency (20%) and GHG emissions (14%), with optimisation of the EF gasifier efficiency only just behind in second place across all three metrics.

From the base case results (Figure 4.16), the CAPEX for the conversion plant is the largest cost of the chain. Optimisation in the EF gasifier CAPEX and the syngas CCGT CAPEX can reduce the total LCOE by 8% and 5% respectively. None of the pelleting parameters are able to achieve more than a 2% reduction in Chain 8 LCOE, including improvements in the pelleting CAPEX and labour OPEX.

Other parameters with innovation potential that can improve the chain net efficiency and GHG emissions include the Syngas clean-up efficiency and the EF gasifier input electricity multiplier (i.e. the parasitic load that needs to be supplied for activities such as pellet grinding).

Other than the conversion sub-unit efficiencies, the largest reduction for the GHG emissions can be found in reducing the EF gasifier input diesel multiplier, which for the base case produces 14 kgCO_{2e}/MWh_e, accounting for 11% of Chain 8 base case GHG emissions.

So, in summary, the largest innovation improvements can be achieved by targeting:

- A 20-40% fall in EF gasifier CAPEX. This relies on cost engineering and design improvements to reduce steel use and biomass handling costs, and reduced installation costs (including reduced EPC profit margins) as the technology is further de-risked and with a future ramp-up to dozens of units per year installed globally.
- A 20-40% fall in syngas CCGT CAPEX. This relies on improved combustor/turbine design and controls optimised for biomass-derived syngas, and reduced installation costs (including reduced EPC profit margins) with the ramp-up to dozens of units per year installed globally.
- A 10-12% increase in EF gasifier efficiency. This relies on improvements in energy integration between the conversion plant components, particularly for the feedstock drying required. Onsite oxygen plants could use cheaper membrane separation technologies.
- A 5% increase in syngas cleanup efficiency. This relies on avoiding large temperature and pressure changes across the various cleanup steps, for example through using hot syngas tar removal. Various options are discussed in the TEABPP D1 report.
- A 10-15% increase in syngas CCGT efficiency. This relies on improved combustor/turbine design optimised for biomass-derived syngas (high in hydrogen), and advanced controls to handle varying syngas compositions (particularly the H₂:CO ratio). Large-scale fuel cell technology could also be a future option for achieving higher efficiencies (although requiring even purer syngas).
- A 20-50% fall in electricity consumption by the EF gasifier. This relies on improvements in biomass grinding (with optimisation for the properties of the TEABPP feedstocks), biomass conveying/handling and gasifier feed pressurisation, and potentially using more novel onsite oxygen generation methods, such as membrane technologies.
- A 20-50% fall in diesel consumption by the EF gasifier. This relies on improved gasification conditions (including faster heating rates during start-up), plus less cycling and fewer start-ups (fewer downtime incidents, noting here that we mean through improved engineering to avoid e.g. blockages, irrespective of the feedstock).

6.5.9 Chain 9 – EF gasifier + syngas CCGT with torrefaction + pelleting

As a reminder, the base values for Chain 9 were LCOE = 132 £/MWh, net efficiency = 26.3%, GHG emissions = 135 kgCO₂e/MWh_e. The optimum values (when optimising all the allowed technical parameters together) are LCOE = 70 £/MWh, net efficiency = 48.4%, GHG emissions = 68 kgCO₂e/MWh_e. Table 6.20 provides a summary of the key innovations that improve Chain 9. A total of 34 parameters were analysed, of which only the most important 12 are shown.

Table 6.20: Key technical innovation parameters within Chain 9

| Input parameter to be optimised (individually) | LCOE when optimised (£/MWh _e) | Change in LCOE from base case | Net efficiency when optimised | Change in net efficiency from base case | GHG emissions when optimised (kgCO ₂ e/MWh _e) | Change in GHG emissions from base case |
|--|---|-------------------------------|-------------------------------|---|--|--|
| CCGT efficiency multiplier | 117 | 11% | 31.7 | 21% | 116 | 14% |
| EF gasifier efficiency multiplier | 120 | 9% | 30.6 | 16% | 119 | 11% |
| Torrefied pelleting LHV multiplier | 122 | 7% | 29.7 | 13% | 123 | 9% |
| EF gasifier total installed CAPEX multiplier | 123 | 7% | 26.3 | 0% | 135 | 0% |
| CCGT total installed CAPEX multiplier | 126 | 5% | 26.3 | 0% | 135 | 0% |
| Torrefied pelleting total installed CAPEX multiplier | 126 | 4% | 26.3 | 0% | 135 | 0% |
| Syngas clean-up efficiency | 127 | 4% | 28.1 | 7% | 128 | 5% |
| Syngas clean-up CAPEX multiplier | 129 | 2% | 26.3 | 0% | 135 | 0% |
| EF gasifier input electricity multiplier | 129 | 2% | 27.8 | 6% | 129 | 4% |
| Torrefied pelleting input electricity multiplier | 130 | 2% | 27.1 | 3% | 122 | 9% |
| Torrefied pelleting input pellet binder multiplier | 130 | 1% | 26.3 | 0% | 132 | 2% |
| EF gasifier input diesel multiplier | 131 | 1% | 27.1 | 3% | 127 | 5% |
| EF gasifier input urea multiplier | 132 | 0% | 26.3 | 0% | 131 | 3% |

Table 6.20 shows that, similar to Chain 8, optimising the CCGT efficiency leads to the largest improvements in LCOE, net efficiency and GHG emissions. The EF gasifier and syngas cleanup efficiencies also remain important to all three metrics, as does the CAPEX of the EF gasifier and syngas CCGT to the Chain 9 LCOE.

However, in addition to these similarities, Chain 9 shows some important differences. Improving the Torrefied pellet LHV is able to decrease the LCOE by 7%, as well as improve chain net efficiency by 13% and GHG emissions by 9% (due to savings in storage, transport and grinding at the EF gasifier). This shows that increasing the output LHV of the torrefaction plant is a key contributor to getting the costs and GHG emissions of Chain 9 lower than Chain 8. As shown in in Table 6.11, the combination of all the pre-processing improvements is sufficient to just cause a cross-over in both metrics (but as shown in Figure 5.10 and Figure 5.11, this is still very uncertain).

So, in summary, the largest innovation improvements for Chain 9 can be achieved with the same targets as given in Chain 8 above, with the following additional targets:

- A 1.17-1.20 target value for the Torrefied pelleting LHV multiplier, i.e. engineering a larger increase in biomass LHV content. The current base case is 1.09. This relies on the improved mechanical design of the reactor, and process conditions (particle size, temperature, pressure, residence time) being optimised to the TEABPP feedstocks.
- A 10-20% fall in the use of electricity in the torrefaction+pelleting plant. This relies on optimisation of the torrefaction process conditions and reactor design for the feedstocks used, in order to then minimise the electricity used in grinding of the torrefied material and in the pellet die (whilst still achieving the required pellet quality). Improvements in the parasitic loads of conveyors, fans & pumps, and reduced ignition requirements (including fewer downtime events) will also assist in meeting these targets.

There are torrefaction+pelleting plant configurations that add water to the torrefied material to aid with pelleting, and the resulting pellets can be at 5-10% moisture content. However, there are other torrefaction+pelleting plants that use higher temperature and pressure dies, plus addition of binder, in order to achieve very low moisture content pellets, such as the 2% assumed in the base case. Alternatively, pelleting before torrefying (instead of after) would also lead to a very low moisture, stable pellet – and this reversed plant configuration could have similar capital costs due to the same pieces of equipment being used in a different order (although is likely to have higher grinding opex). There are therefore a variety of different options available which could have been characterised as the base case technology.

If the TEABPP consortium had instead assumed a higher moisture content pellet for the base case, this would have led to slightly higher⁴⁵ Chain 5 costs at the base case, and fewer cross-overs achieved in Section 5, although little change to the key sensitivities. However, with the same optimum very low moisture content, the same optimum case results in Table 6.11 would have been achieved, but Section 6 would then very likely have highlighted the torrefied pellet moisture content as a key innovation opportunity. So depending on the base case torrefaction+pelleting assumptions, optimising for the output moisture content may, or may not, be a key innovation opportunity.

6.5.10 Chain 10 – EF gasifier + syngas CCGT with pyrolysis

As a reminder, the base values for Chain 10 were LCOE = 182 £/MWh, net efficiency = 17.9%, GHG emissions = 100 kgCO₂e/MWh_e. The optimum values (when optimising all the allowed technical parameters together) are LCOE = 74 £/MWh, net efficiency = 44.5%, GHG emissions = 24 kgCO₂e/MWh_e. Table 6.21 provides a summary of the key innovations that improve Chain 10. A total of 40 parameters were analysed, of which only the most important 17 are shown.

Table 6.21 shows that an improved Pyrolysis efficiency multiplier leads to the largest improvement in LCOE (of 17%) and net efficiency (of 44%), while maximising the Pyrolysis electricity output multiplier (the exported power from the pyrolysis unit) leads to the largest fall in GHG emissions.

As in Chain 8, the EF gasifier efficiency and syngas CCGT efficiency can strongly improve LCOE, net efficiency and GHG emissions (and to a lesser extent, the syngas cleanup efficiency can also assist).

⁴⁵ To give an indication, selecting a 7.5% base case for the torrefied pellet moisture content would increase the base case Chain 9 LCOE by approximately £5/MWh_e, due to more transport of water in the pellets, and lower EF gasifier efficiency.

Looking at Table 4.11, for the base case, Chain 10 has the lowest net efficiency. This is mainly due to the low efficiency of the pyrolysis unit (53.8% at the base case), which is much lower than the other pre-processing technologies. Thus, it should be expected that an increase in efficiency of this unit would lead to a significant increase in the overall efficiency. Moreover, an increase in the efficiency of the pyrolysis unit will lead to a drop in its required capacity, which in turn will reduce its levelised CAPEX – currently the main cost for Chain 10 (as shown in Figure 4.20). Separately to the efficiency, optimising the pyrolysis CAPEX can reduce the LCOE by 8%.

The (currently⁴⁶) largest decrease in GHG emissions is achieved through optimising the Pyrolysis electricity output multiplier. Excess electricity is exported and is given a GHG emissions credit, so an increase in these exports increases this GHG credit. Minimising the diesel use in the EF gasifier also has an impact, reducing GHG emissions of 7%.

Table 6.21: Key technical innovation parameters within Chain 10

| Input parameter to be optimised (individually) | LCOE when optimised (£/MWh _e) | Change in LCOE from base case | Net efficiency when optimised | Change in net efficiency from base case | GHG emissions when optimised (kgCO ₂ e/MWh _e) | Change in GHG emissions from base case |
|--|---|-------------------------------|-------------------------------|---|--|--|
| Pyrolysis efficiency multiplier | 151 | 17% | 25.8 | 44% | 75 | 25% |
| CCGT efficiency multiplier | 161 | 12% | 21.4 | 19% | 86 | 14% |
| EF gasifier efficiency multiplier | 165 | 9% | 20.7 | 15% | 88 | 12% |
| Pyrolysis total installed CAPEX multiplier | 167 | 8% | 17.9 | 0% | 100 | 0% |
| EF gasifier total installed CAPEX multiplier | 168 | 8% | 17.9 | 0% | 100 | 0% |
| Syngas clean-up efficiency | 175 | 4% | 19.1 | 6% | 94 | 5% |
| CCGT total installed CAPEX multiplier | 176 | 4% | 17.9 | 0% | 100 | 0% |
| Pyrolysis oil LHV | 177 | 3% | 18.2 | 2% | 99 | 1% |
| Pyrolysis electricity output multiplier | 178 | 2% | 19.1 | 6% | 73 | 27% |
| EF gasifier input electricity multiplier | 179 | 2% | 19.2 | 7% | 94 | 6% |
| Pyrolysis lifetime | 179 | 2% | 17.9 | 0% | 100 | 0% |
| Pyrolysis variable OPEX labour multiplier | 179 | 2% | 17.9 | 0% | 100 | 0% |
| Miscanthus chips storage time | 179 | 2% | 18.4 | 2% | 98 | 1% |
| Woody chips storage time | 179 | 2% | 18.6 | 3% | 97 | 3% |
| Pyrolysis oil moisture content | 181 | 1% | 18.4 | 3% | 96 | 3% |
| EF gasifier input diesel multiplier | 181 | 1% | 18.5 | 3% | 92 | 7% |
| Pyrolysis urea input multiplier | 182 | 0% | 17.9 | 0% | 96 | 4% |

⁴⁶ Exported power from the pyrolysis plant in Chain 10 is not counted in the final power generation figures, but is currently allocated a GHG emission credit equal to the current UK grid average GHG intensity, thereby benefiting Chain 10 GHG emissions by ~9 kgCO₂e/MWh_e in the base case. However, the UK grid GHG intensity is falling rapidly, and expected to continue to do so, so the importance of this exported power credit will diminish rapidly. The EU RED II also has proposed new accounting rules that may change these calculations.

However, as shown in Table 6.11, even the combination of all these pyrolysis improvements are not enough to make Chain 10 cheaper than Chains 9 or 8, when these other chains are also optimised.

So, in summary, the largest innovation improvements for Chain 9 can be achieved with the same targets as given in Chain 8 above, with the following additional targets:

- A 20-40% increase in the pyrolysis plant efficiency (albeit from a relatively low assumed starting position). This relies on increasing the bio-oil yield and its LHV, and mitigating the impact of ash via modified catalysts and enhanced catalyst regeneration. It also heavily relies on optimising the overall plant energy balance (as discussed in the bullet below). Academic sensitivity studies^{47,48} consider pyrolysis unit efficiencies up to 70% are possible.
- A 100-200% increase in the export of excess electricity from the pyrolysis plant (from a small starting position). This relies on improvements in energy integration between the pyrolysis plant components, particularly steam use in feedstock drying, and minimisation of feedstock grinding power requirements. Higher steam temperatures/pressures would increase the power generation efficiency, but boilers capable of achieving this whilst burning gases and chars high in contaminants and ash will be more expensive. There is another important trade-off, since maximising the pyrolysis plant bio-oil yield (to meet the critical targets in the bullet above) will reduce the gas and char fractions available for power generation – i.e. the targets in this bullet should likely be deprioritised compared to the first bullet (and given that the GHG emission benefit is rapidly disappearing as the UK grid decarbonises).
- A 20-35% fall in pyrolysis plant CAPEX. This relies on selection and further optimisation of the reactor design and process conditions for the TEABPP feedstocks, cost engineering and design improvements to reduce steel use and biomass handling & grinding costs, and reduced installation costs (including reduced EPC profit margins) as the technology is de-risked and with the ramp-up to hundreds of units per year installed globally.

⁴⁷ Rogers J.G., Brammer J.G. (2012) "Estimation of the production cost of fast pyrolysis bio-oil". *Biomass and Bioenergy*, 36, 208-217

⁴⁸ Shemfe, Gu & Ranganathan (2015) "Techno-economic performance analysis of biofuel production and miniature electric power generation from biomass fast pyrolysis and bio-oil upgrading", *Fuel*, 143, p 361-372

6.6 Summary of innovation findings

A summary of the top 3 innovation opportunities for each chain and for each metric is given below in Table 6.22. Some cells are blank, as the impact of the next most important innovation was too small to be worth showing (e.g. <1%-point efficiency gained, or <1kgCO₂e/MWh). Note that because the base case values are all different, Table 6.22 shows the absolute changes in the metrics due to the innovations, to make these findings more comparable between different chains (rather than using % differences as in Section 6.5). However, as in Section 6.5, these values are not additive, as the changes are for independent parameters from the base case.

Even with using absolute values, knowledge of the base cases is still required, since for example, innovation in the BFB gasifier CAPEX achieves a fall of £44/MWh_e in Chain 3, but only a fall of £33/MWh_e in Chain 4. This is because the base case costs of the conversion plant in Chain 4 are already ~£20/MWh lower than in Chain 3, due to Chain 4 having higher conversion efficiencies from using dry, clean pellets instead of wet, less clean chips. Therefore the BFB gasifier CAPEX innovations have a smaller absolute impact in Chain 4 than in Chain 3.

Pre-processing innovations are highlighted with coloured cells. Those pre-processing innovations able to achieve a cross-over are highlighted in Table 6.12 in **deep purple** (noting that pyrolysis GHG changes have started already crossed-over). Those innovations able to close the gap by 30-100% are given in **light purple**, and those by <30% in **grey** (to roughly match the Venn diagram categories, noting that the uncertainties around these results have not been analysed in detail).

As a reminder to set the pre-processing innovation changes in context, the absolute deltas between the base cases are as follows:

- Chain 2 vs. 1: LCOE Δ = £3/MWh_{th}, net eff Δ = 2.8%-points, GHG Δ = 4 kgCO₂e/MWh_{th}
- Chain 4 vs. 3: LCOE Δ = £25/MWh_e, net eff Δ = 5.8%-points, GHG Δ = 88 kgCO₂e/MWh_e
- Chain 6 vs. 5: LCOE Δ = £21/MWh_e, net eff Δ = 2.9%-points, GHG Δ = 58 kgCO₂e/MWh_e
- Chain 7 vs. 5: LCOE Δ = £40/MWh_e, net eff Δ = 4.3%-points, GHG Δ = 110 kgCO₂e/MWh_e
- Chain 9 vs. 8: LCOE Δ = £8/MWh_e, net eff Δ = 3.5%-points, GHG Δ = 205 kgCO₂e/MWh_e
- Chain 10 vs. 8: LCOE Δ = £58/MWh_e, net eff Δ = 11.8%-points, GHG Δ = -23 kgCO₂e/MWh_e

Table 6.22: Top 3 technical innovation parameter impacts for each chain

| Chain | LCOE reductions (£/MWh) | | Efficiency increases (%-points) | | GHG emission reductions (kgCO ₂ e/MWh) | |
|-------------|--------------------------------|-----------|---------------------------------|-------------|---|-----------|
| | | | | | | |
| 1 (heat) | Boiler CAPEX | 8 | Boiler efficiency | 11.3% | Boiler electricity use | 11 |
| | Boiler efficiency | 6 | Boiler electricity use | 1.9% | Boiler efficiency | 2 |
| | Boiler electricity use | 2 | | | | |
| 2 (heat) | Boiler CAPEX | 8 | Boiler efficiency | 11.0% | Boiler electricity use | 11 |
| | Boiler efficiency | 7 | Boiler electricity use | 1.8% | Boiler efficiency | 3 |
| | Boiler electricity use | 2 | | | | |
| 3 | BFB gasifier CAPEX | 44 | Syngas engine efficiency | 4.2% | BFB gasifier diesel use | 16 |
| | Syngas engine efficiency | 17 | BFB gasifier efficiency | 3.3% | Syngas engine efficiency | 11 |
| | BFB gasifier efficiency | 14 | Syngas cleanup efficiency | 3.0% | BFB gasifier efficiency | 9 |
| 4 | BFB gasifier CAPEX | 33 | Syngas engine efficiency | 3.9% | Syngas engine efficiency | 23 |
| | Syngas engine efficiency | 21 | BFB gasifier efficiency | 3.1% | BFB gasifier efficiency | 19 |
| | BFB gasifier efficiency | 17 | Syngas cleanup efficiency | 2.8% | Syngas cleanup efficiency | 17 |
| 5 | CFB combustion CAPEX | 20 | CFB combustion efficiency | 4.1% | CFB combustion efficiency | 10 |
| | CFB combustion efficiency | 13 | | | CFB combustion diesel use | 4 |
| | CFB combustion lifetime | 4 | | | Screening diesel use | 3 |
| 6 | CFB combustion CAPEX | 19 | CFB combustion efficiency | 4.1% | CFB combustion efficiency | 10 |
| | CFB combustion efficiency | 15 | | | Pelleting electricity use | 6 |
| | CFB combustion lifetime | 4 | | | Pelleting binder use | 5 |
| 7 | CFB combustion CAPEX | 17 | CFB combustion efficiency | 4.0% | CFB combustion efficiency | 23 |
| | CFB combustion efficiency | 17 | | | Chemical wash N content | 16 |
| | Chemical wash N content | 5 | | | Chemical wash alkali use | 13 |
| 8 | CCGT efficiency | 13 | CCGT efficiency | 6.1% | CCGT efficiency | 17 |
| | EF gasifier efficiency | 11 | EF gasifier efficiency | 4.9% | EF gasifier efficiency | 14 |
| | EF gasifier CAPEX | 10 | Syngas cleanup efficiency | 2.0% | EF gasifier input diesel | 7 |
| 9 | CCGT efficiency | 15 | CCGT efficiency | 5.4% | CCGT efficiency | 18 |
| | EF gasifier efficiency | 12 | EF gasifier efficiency | 4.3% | EF gasifier efficiency | 15 |
| | Torrefied pellet LHV | 10 | Torrefied pellet LHV | 3.5% | Torrefied pellet electricity use | 12 |
| 10 | Pyrolysis efficiency | 32 | Pyrolysis efficiency | 7.9% | Pyrolysis electricity export | 27 |
| | CCGT efficiency | 21 | CCGT efficiency | 3.4% | Pyrolysis efficiency | 25 |
| | EF gasifier efficiency | 17 | EF gasifier efficiency | 2.8% | CCGT efficiency | 14 |

Starting with the conversion technologies discussed in Section 6.5 above, innovation opportunities to reduce conversion plant CAPEX and improve conversion plant efficiencies are the strongest drivers of LCOE and net efficiency improvements within each chain. Reduced consumption of electricity or diesel by the conversion technologies typically present more limited opportunities to save costs, and mainly improve chain net efficiency or GHG emissions.

Although there are some variations in the impact these conversion technology improvements have on each chain (given the different upstream supply chains and different base case values), these conversion technology improvements are expected to be replicated within each chain grouping, and so are not a fundamental driver of new situations when pre-processing pays off or not.

Looking across the different pre-processing technologies, there are innovation opportunities within field washing, water washing and pelleting, but none of these alone (or combined) are expected to be significant enough to noticeably change the costs and efficiencies of their respective chains (Chains 2, 4, 6 and 8). Only a handful of pelleting innovations (reducing binder and electricity use) are expected to modestly improve GHG emissions.

Torrefaction + pelleting plant innovations (as explained at the end of Section 6.5.9) show potential for larger LCOE reductions, as they could potentially achieve an overall lower chain LCOE than simple pelleting when both systems are fully optimised (although subject to uncertainties). Looking at Table 6.22, an improvement of 10 £/MWh_e can be achieved by increasing only the Torrefied pelleting LHV multiplier (as explained at the end of Section 6.5.9). This is enough to make Chain 9 just cheaper than Chain 8, as the LCOE delta at the base case is 8 £/MWh_e (Table 4.11) – but this result is still uncertain. Similarly, only decreasing the Torrefied pelleting electricity use multiplier could be enough to make Chain 9 have the same GHG emissions as Chain 8 (based on exact figures, not the rounded numbers in Table 4.11 and Table 6.22).

Pyrolysis units can be self-sufficient, so of the power generation chains, Chain 10 has the lowest GHG emissions, and further GHG reductions may be possible if the export power and pyrolysis efficiency are increased. The high LCOE cost for the base case (182 £/MWh_e) can be significantly reduced by optimising the pyrolysis efficiency and reducing pyrolysis unit CAPEX, but still not enough to create a cross-over in either the LCOE or net efficiency metrics. The uncertainties in Chain 10 are also extremely high, due to model runs where high ash contents give very low pyrolysis efficiencies, which then accentuate the rest of the upstream uncertainties.

Optimising chemical washing within Chain 7 also shows some promise, as a reduction in the outlet nitrogen content can reduce the cost of the CFB combustion boiler and reduce the GHG emissions from urea. Reduction in alkali use also lowers GHG emissions. However, this is still the most expensive of all the optimised chains, and the chain with the highest GHG emissions, and so further reductions in cost and GHG emissions would likely have to be found for chemical washing to be considered. The use of new alkali chemicals and combining reactor vessels are likely avenues for further investigation.

7 Setting innovation findings in a UK context

Whilst the above analysis has been focused on costs, efficiencies and emissions, there are several other critical factors that determine whether or not a technology is likely to play an important role in supporting lower cost and lower emission bioenergy provision in the UK, and how attractive or risky the resulting supply chains could be from a UK perspective.

These additional factors include: the commercial status and key development issues for the technologies involved, UK actors, supply chain risks and barriers, and potential deployment opportunities within the UK. This section summarises key messages from the D1 benchmarking and review report, with additional input from B&V, ICON and Sheffield. We present these in two sections: Section 7.1 discusses TRL status, technical issues and UK actors related to specific technologies (to avoid repeating this technology information between similar chains), and Section 7.2 discusses chain level factors such as risks and barriers, and UK deployment opportunities related to specific chains. Note that the economic opportunities for the UK in exporting different chains or technologies have not been examined as part of the study scope.

7.1 Technologies

7.1.1 Field washing

Field washing is very simple in-field washing of biomass, predominantly to remove soil and stones, along with some reduction in halides. The equipment required is modelled in this project as a single small steel tank with cold water sprays inside it, with no prior screening, re-sizing or subsequent waste water treatment. There are also no contaminant disposal costs, as these flows are returned straight to the field. Some examples of small-scale in-field washers are available, for example from Grindstone Farm in the USA⁴⁹, but they are used for root crops such as potatoes and carrots, and are not optimised for biomass washing. As a result, this technology is judged to be at TRL 7, which is the same as water washing.

Currently there are no major technical issues expected with field washing technology, but there is significant opportunity for optimisation of the technology for biomass feedstocks.

There is little UK activity in field washing, but the companies offering water washing technology (see below) are likely to have relevant expertise and could potentially scale-down their equipment to be suitable for field washing. Academic research into the impact of water washing on biomass, for example at the University of Leeds⁵⁰, also has relevance for field washing.

7.1.2 Water washing

Water washing of biomass involves screening to remove large stones, chipping, magnetic screening to remove metals, washing in water, and filtering. This process reduces the amount of alkali metals (potassium and sodium), sulphur and chlorine in the biomass, as the presence of these elements in the feedstock can lead to several problems for downstream conversion equipment, including

⁴⁹ Grindstone Farm, Root Crop Washers. <http://www.grindstonefarm.com/ordering/root-crop-washer/> (Accessed 24th August 2017)

⁵⁰ Gudka, Jones et al. (2016) "A review of the mitigation of deposition and emission problems during biomass combustion through washing pre-treatment", Available at: <http://eprints.whiterose.ac.uk/83581/10/Mitigation%20of%20deposition%20and%20emission%20problems%20during%20biomass%20combustion.pdf>

slagging, fouling and corrosion. Washing with higher temperature water (up to ~90°C) can increase the efficiency with which these impurities are removed. To-date, water washing has been primarily developed for the agricultural produce sector, and currently the maximum scale of washer available is 80 tonnes/hr. It is therefore currently at TRL 7, although adaptation to biomass chips and reaching mass deployment of TRL 9 should be possible within the next 10 years, if there is sufficient industry interest.

Technical issues with water washing are yet to arise, because it has not yet been optimised for washing of biomass for energy generation, or scaled up to commercial-scale. Similar issues might be expected to arise during screening, with binding/blockage issues, variable removal rates and noise. In addition, treatment of wastewater from water washing of biomass can be challenging, in particular when there is a high concentration of sulphates or phosphates in the effluent, creating a risk of downstream eutrophication. Moreover, drying of biomass, both before the washing step so that the biomass can be ground into smaller particles, and after the drying step so that it is at an appropriate moisture content for downstream conversion, can be costly and energy-intensive – although this can be partly mitigated by optimised natural drying in storage. There is a technical challenge around optimising particle size reduction, washing conditions, and subsequent drying requirements for the most effective overall operation of the process.

There are companies in the UK which currently supply washing machinery, but they tend to focus either on crop/vegetable washing, such as Haith Group⁵¹, Tong Engineering Ltd.⁵² and Alvan Blanch⁵³, or on materials/waste washing, such as Blue Group⁵⁴. A project aiming to specifically develop water washing technology for biomass is currently being coordinated by the ETI⁵⁵, with Forest Fuels building a prototype water washing plant in the UK, for analysis and combustion testing of the cleaned biomass, which will build up UK capabilities. University of Leeds⁵⁶ also have expertise in biomass water washing (with University of Sheffield focusing on washed biomass combustion characteristics).

7.1.3 Chemical washing

Chemical washing of biomass involves screening to remove large stones, chipping, magnetic screening to remove metals, washing in water followed by washing in alkali solution, and finally washing in strong acid, before a final rinse with water and filtering. This process is highly effective at removing ash, alkali and earth alkali metals in the biomass, and other contaminants such as sulphur and silicon. Currently there are no known plants using this technology on an industrial scale, and it has only been demonstrated in the lab. Chemical washing is considered to be at TRL 4.

⁵¹ Haith Group, Washing. <http://www.haith.co.uk/washing-and-polishing/washing/> (Accessed 24th August 2017)

⁵² Tong Engineering Ltd, Mobile Vegetable Washers. <http://tongengineering.com/product/mobile-vegetable-potato-carrot-washers/> (Accessed 24th August 2017)

⁵³ Alvan Blanch, Washing Systems. <http://www.alvanblanchgroup.com/washing-systems/> (Accessed 24th August 2017)

⁵⁴ Blue Group. <http://www.blue-group.com/en/> (Accessed 24th August 2017)

⁵⁵ Forest Fuels (2017) Forest Fuels wins project to remove impurities from biomass to make bioenergy cheaper and more efficient, <https://www.forestfuels.co.uk/forest-fuels-wins-project-to-remove-impurities-from-biomass-to-make-bioenergy-cheaper-and-more-efficient/> (Accessed 9th August 2017)

⁵⁶ Gudka, Jones et al. (2016) "A review of the mitigation of deposition and emission problems during biomass combustion through washing pre-treatment", Available at: <http://eprints.whiterose.ac.uk/83581/10/Mitigation%20of%20deposition%20and%20emission%20problems%20during%20biomass%20combustion.pdf>

No pilot or demonstration-scale chemical washing trials have been carried out, therefore technical issues at these scales are not yet well understood. Nevertheless, it is likely that chemical washing will share all of the issues identified for water washing, with additional potential challenges due to the even higher concentrations of elements in the effluent (and the need to regulate its pH level), plus greater safety concerns (due to use of strong acid and alkali solutions).

There is currently only academic activity in the UK concerning biomass chemical washing, with the research group of Prof. Jones at the University of Leeds⁵⁷ having specific experience in this field.

7.1.4 Screening

Screening is a process for the separation of feedstocks into at least two size fractions: oversize material (which remains on the screen) and undersize material (which passes through the screen). Two main types of screens have been used for woody biomass screening to-date: vibrating and disk screens. These screens have been extensively used in the forest products industry worldwide, and are at TRL 9.

Biomass can be a challenging material to screen as it binds together, does not flow well, can vary in moisture content and density, and can freeze or catch fire easily. Some screens may block when processing high moisture content feedstock as smaller particles will clump together or stick to larger particles, which reduces the efficiency of screening. Other issues associated with screening technologies are that they may be very noisy to operate, and can become blocked easily.

Some of the leading global developers include Lubo Systems Screening & Recycling, Vecoplan and Komptech. Most vendors for screening in UK are based in Scandinavia or mainland Europe, but active UK actors include Saxlund International UK⁵⁸, and those with a UK office include Vecoplan⁵⁹ and Komptech⁶⁰.

7.1.5 Pelletizing

Pellets are a biomass product with high energy density that can be easily and cheaply transported. They have a standard size and composition, meaning they are now widely traded and allow the automatic feeding of downstream conversion processes. There are many commercial pellet plants operating worldwide, and in the UK, at both large and small scale, with global production of wood pellets at ~25 million tonnes per annum. The technology is considered to be at TRL 9.

All the TEABPP feedstocks are suitable for pelletizing, but there are still some minor technical issues. Milling power consumption increases with small changes in moisture content, and so the prior drying step (a high energy demand) needs to be tightly controlled. Different lignin contents and feedstock types also require precise tuning of pressure, temperature and the amount of binder used in the milling process to avoid stoppages, equipment degradation and unnecessarily high power consumption.

Other technical issues relate to pellet storage and transportation. Wood pellets cannot be stored outside as they absorb moisture and disintegrate. Also, durability of pellets is usually achieved at the

⁵⁷ Saddawi A., Jones J.M., Williams A., Le Couer C. (2012) Commodity Fuels from Biomass through Pretreatment and Torrefaction: Effects of Mineral Content on Torrefied Fuel Characteristics and Quality. *Energy & Fuels*, 26, 6646-6474

⁵⁸ Saxlund www.saxlund.co.uk (accessed 24th August 2017)

⁵⁹ Vecoplan www.vecoplan.com/products/screening/ (accessed 24th August 2017)

⁶⁰ Komptech www.komptech.com (accessed 24th August 2017)

cost of high throughput, so a balance must be struck between these two characteristics. Low throughput increases costs, but poor durability can lead to increased dust levels and decomposition during storage to produce gases which present an increased fire and safety risk.

Most vendors for pelleting in UK are based in Scandinavia or mainland Europe UK, but those pellet technology providers with UK offices include Andritz Feed & Biofuel⁶¹, CPM Europe B.V.⁶² and Bühler AG⁶³.

7.1.6 Pyrolysis

Pyrolysis converts biomass into three product streams: liquid (bio-oil), gas and solid (biochar). In general when pyrolysis is used as a biomass pre-processing technique, fast pyrolysis is used, which maximises the yield of the (high-density) liquid fraction and minimises (low density) solid and gaseous products. Many demonstration and first-commercial pyrolysis plants have been constructed (30 – 192 tonnes/day), predominantly in the USA and Canada, but as the technology still has not been fully commercialised, it is considered to be at TRL 8.

A key technical challenge of pyrolysis remains the properties of the bio-oil itself, which is highly acidic, has poor stability and low pH. Pumping, storage and tanker equipment may need protection from corrosion by the bio-oil, and additional safety measures are likely to be required in handling and storage of the oil. In addition, it is prone to chemical degradation, and may undergo phase separation – stability during very long-term storage (over several years) is yet to be proven. Feedstocks with high ash content can significantly reduce the yield of bio-oil and increase the yield of biochar. Small feedstock particle sizes and low moisture contents are also required in order to ensure high conversion efficiency and reliable operation.

There are companies in the UK developing pyrolysis plants and new pyrolysis technologies, including 2G BioPOWER; Anergy; CARE (Conversion and Research Evaluation Ltd.); Environmental Power International; Next BTL LLC (which acquired Future Blends in 2016); and Torftech. Cynar plc was liquidated last year⁶⁴. In addition, many UK universities have activities in pyrolysis⁶⁵, with the main hub of UK capabilities located at Aston University as part of the European Bioenergy Research institute (EBRI).

7.1.7 Torrefaction + pelleting

Torrefaction involves heating biomass in limited oxygen to evaporate moisture and drive off volatile components. The resultant biomass is more energy dense and can be more easily ground into powder for subsequent pelleting. The resultant pellets are mechanically strong and have a high energy density, but can still be ground easily. Torrefaction today is judged to be at TRL 8 when operating on forestry and sawmill residues, and as pelleting is a fully commercialised process, torrefaction + pelleting is also judged to be at TRL 8. Commercial plants torrefying straw and Miscanthus have not yet been established.

⁶¹ Andritz Feed and Biofuel <https://www.andritz.com/feed-and-biofuel-en/locations/hull-united-kingdom> (accessed 24th August 2017)

⁶² CPM Europe www.cpmeurope.nl (accessed 24th August 2017)

⁶³ Bühler Group www.buhlergroup.com (accessed 24th August 2017)

⁶⁴ Companies House (2016) "CYNAR PUBLIC LIMITED COMPANY", available at: <https://beta.companieshouse.gov.uk/company/04960594/insolvency>

⁶⁵ EBRI (2015) "UK Biomass and waste pyrolysis guide", available at: <http://www.pyne.co.uk/Resources/user/UK%20Biomass%20and%20Waste%20Pyrolysis%20Guide%202015%20081015.pdf>

There are no severe technical challenges to torrefaction + pelleting, although some are shared with pelleting. The energy use in drying before torrefaction needs tight control, particularly given the presence of halides in the volatile gases that are combusted for heat. However, the ability to work only within a narrow range of particle sizes, and the current lack of development for non-wood feedstocks are some limitations of this process, as there is more limited experience with lower lignin content feedstocks such as straw and Miscanthus.

Relevant UK actors include Torftech⁶⁶, and the Supergen Energy Hub⁶⁷ (who are looking at the impacts of incorporating torrefaction into bioenergy systems). Clean Electricity Generation B.V.⁶⁸ are also operating a wood-based demonstration plant in Derby (and are planning to use the torrefaction gases to generate 2.2MW_e from four syngas engines).

7.1.8 Underfeed stoker combustion boiler

Underfeed stoker boilers combust biomass to provide process or space heating at scales of typically up to ~2MW_{th} output. They are currently at TRL 9 and are considered operationally safe and relatively simple and cheap to construct, therefore are popular at small scales.

Although mature, there are a number of technical issues to note, mostly caused by use of variable or more challenging feedstocks. In general, strict feedstock moisture limits are specified by boiler manufacturers in order to ensure emissions stay below required levels, and to avoid incomplete feedstock burnout. High moisture can increase the likelihood of corrosive condensation, leading to faster equipment degradation. Conversely, fuel that is too dry may burn too strongly, with the resultant intense heat causing damage within the furnace. Inhomogeneous particle sizes can disrupt the small, intense combustion zone, resulting in blockages or incomplete burn out. Ash-rich feedstocks (such as Miscanthus) can also be problematic, as sintered or melted ash particles covering the upper surface of the fuel bed can cause unstable combustion conditions. Biomass ash and chemical contaminants can also cause slagging in the furnace and fouling of heat-exchanger tubes, which can result in additional boiler shut-downs for cleaning.

There are a large number of underfeed stoker manufacturers based in mainland Europe (particularly in Austria). Several of these manufacturers have a UK presence, including Kohlback Group⁶⁹ (represented in the UK via Cochran UK), Fröling GmbH⁷⁰ (represented via British Gas/Econergy Ltd), and Binder Energietechnik GbmH, part of the Herz Group⁷¹ (represented via Rural Energy). Hoval⁷² also design and manufacture their STU boiler in the UK.

7.1.9 CFB combustion

Circulating fluidised bed boilers typically operate at scales above 75 – 100MW_e, where the ability to feed large volumes of biomass into the circulating media gives them an advantage over other boiler types. CFB boilers typically provide power only, due to the lack of heat demand at such large scales,

⁶⁶ Torftech http://www.torftech.com/applications/biomass_processing.html (accessed 24th August 2017)

⁶⁷ Supergen-Bioenergy (2017) "Torrefaction integrated assessment", available at: <http://www.supergen-bioenergy.net/research-projects/torrefaction-integrated-assessment/>

⁶⁸ CEG (2017) "The CEG Torrefaction Production Line", available at: <http://cegeneration.com/technology.html#system>

⁶⁹ Kohlback Group www.kohlback.at (accessed 24th August 2017)

⁷⁰ Fröling GmbH www.froeling.com (accessed 24th August 2017)

⁷¹ Binder Energietechnik GbmH www.binder-gmbh.at (accessed 24th August 2017)

⁷² Hoval <http://www.hoval.co.uk/products/wood-pellet-boiler-stu/> (accessed 1st September 2017)

but may provide some heat if demand is there. Biomass CFB boilers combined with steam turbines were commercialised at scales above 100MW_e in the 1990s and are therefore at TRL 9.

Given the extensive commercial experience with CFB biomass combustion boilers, the technical issues that remain to be solved are not severe. Feedstock moisture reduces efficiency, and alkali metals cause biomass ash to be stickier than coal ash, which can create serious slagging and fouling problems, and can lead to bed agglomeration. Uniform fluidisation is very important in order to avoid formation of hot and cold spots, and due to the high fluidizing speed, auxiliary power requirements for CFB boilers are higher compared to other biomass boiler types.

There are no direct UK suppliers of biomass CFB boilers (with UK-headquartered Amec Foster Wheeler⁷³ having recently sold its boiler business to Sumitomo Heavy Industries⁷⁴), although there are suppliers active in the UK that could supply the technology. Those with UK offices include Doosan Lentjes⁷⁵, Metso Power⁷⁶, Babcock & Wilcox Vølund A/S⁷⁷, Andritz Energy & Environment GmbH⁷⁸, and Valmet⁷⁹. Several of these developers provide both BFB and CFB-configuration combustors and gasifiers.

7.1.10 BFB gasifier + syngas engine

While a large number of pilot and demonstration biomass BFB gasifiers have been constructed, there are only a few small commercial biomass BFB gasifier plants up to ~25 MW_{th} output operational globally, giving this technology a TRL of 8. BFB gasifiers have a high tolerance to different feedstocks, and are less sensitive to variations in feedstock characteristics or composition than other gasifiers. The remaining technical challenges are modest, and include optimising yields and syngas quality (including tar content) with a broader range of feedstocks.

Syngas engines are modified natural gas engines, which generally operate at 300kW_e to 10MW_e scale. They are in fairly common use, but are judged to be around TRL 8 as deployment is not completely widespread and best practice is not fully disseminated. While there are not extensive technical issues, there is considerable scope for optimisation of the engine to deal with syngas fuel, particularly syngas of varying composition (due to gasification of variable biomass feedstocks).

The UK lags other parts of the world in the development of gasification systems, and lacks UK developers of BFB technology, but there have been several recent projects. There are 16 gasifiers currently planned or under construction in the UK, with the most relevant of these to producing high quality syngas for downstream applications being Advanced Plasma Power (using imported Outotec BFB gasifier technology)^{80,81}, illustrating some wider UK capability in this area.

⁷³ Amec Foster Wheeler (2012) "Pioneering CFB Technology", available at: <https://www.amecfw.com/documents/brochures-publications/brochures/pioneering-cfb-technology.pdf>

⁷⁴ Amec Foster Wheeler (2017) "Amec Foster Wheeler wins contract for multi-fuel CFB designed to burn 100% biomass", available at: <http://media.amecfw.com/contract-for-multi-fuel-cfb-designed-to-burn-100-biomass/>

⁷⁵ Doosan Lentjes (2016) "Circulating Fluidised Bed Boiler Technologies", available at: <http://www.doosanlentjes.com/common/pdf/CFBBrochure.pdf>

⁷⁶ Metso (2010) "Metso to supply biomass boiler to RWE npower renewables, UK", available at: <http://www.metso.com/news/2010/2/metso-to-supply-biomass-boiler-to-rwe-npower-renewables-uk/>

⁷⁷ Babcock & Wilcox Vølund <http://www.volund.dk/> (accessed 24th August 2017)

⁷⁸ Andritz <https://www.andritz.com/products-en/group/environmental-solutions/powerfluid-boilers> (accessed 24th August 2017)

⁷⁹ Valmet (2017) "CYMIC boilers", available at: <http://www.valmet.com/energyproduction/cfb-boilers/> (accessed 24th August 2017)

⁸⁰ Power technology (n.d.) Energy Works power plant project, Hull, United Kingdom, <http://www.power-technology.com/projects/energy-works-power-plant-project-hull/> (Accessed 9th August 2017)

Large engine OEMs such as Jenbacher have developed syngas engines. Although not based in the UK, these companies generally have a UK presence, for example Clarke Energy are a reseller for Jenbacher in the UK, therefore have technical knowledge of syngas engines. To date, no syngas engines have yet been deployed in the UK (previous successful gasification projects in the UK have only used steam cycles) – it is unclear whether the CEG torrefaction plant in Derby has started burning torrefaction syngas in their planned syngas engines (or whether they are only producing biochar at present)⁸². However, the BFB gasification project⁸³ being developed by SynTech Bioenergy and supported by the ETI will be using a syngas engine, building up UK capabilities and experience in this technology. European experience with gasification and syngas engines is considerably higher than in the UK, although with the syngas typically used to drive steam cycles, not gas engines.

7.1.11 EF gasifier + syngas CCGT

Entrained flow gasifiers operate worldwide at very large scales (~100s of MWs) for gasification of coal, and it is anticipated that commercial-scale operation with biomass would be at a scale of 100MW_{th} to 2000MW_{th}. Entrained flow gasifiers can accept a wide variety of biomass feedstocks, but there are stringent requirements around the moisture content and particle size. There have been some large scale co-gasification trials of biomass with coal, and entrained flow biomass gasifiers have been operated at pilot scale, however developers have had difficulties scaling-up the technology. The global status of this technology for biomass is therefore judged to be at TRL 6.

Given that entrained flow gasifiers are already used extensively for coal gasification, most of the technical issues associated with them are around adaptation for biomass feedstocks, including difficulties grinding biomass to the small particle sizes required and high tar formation.

CCGT plants are very commonly used worldwide with natural gas, and there is growing use of CCGT with syngas, which may require some modification to the plant design. While there has been extensive operation of CCGT with fossil-derived syngas, there are no IGCC plants currently known to be running using biomass syngas, therefore it is judged to be at TRL 8. Because CCGT with natural gas is a mature technology, technical challenges mostly concern optimisation of the CCGT for use with syngas, particularly where the composition of the syngas is variable due to changing biomass compositions.

There are no entrained flow gasification projects operating or proposed in the UK (using biomass, coal or any other feedstock). Given the significant differences between EF gasifiers and other gasifier types, including the large scale they typically operate at and the requirement for finely-ground feedstock, this is a gap in UK capabilities, compared to other countries that already have large-scale operating EF gasifiers (using coal or fossil wastes). However, global EF gasifier experience with biomass is limited, and hence this capability gap when using biomass also exists globally.

There are currently no UK actors operating CCGT plants using syngas globally, nor any UK CCGT plants using syngas. Global experience with syngas CCGT plants is dominated by turbines manufactured by Siemens and GE, and to-date has predominantly been with coal-based integrated

⁸¹ ETI (2017) "Targeting new and clean uses for wastes and biomass using gasification", <http://www.eti.co.uk/insights/targeting-new-and-cleaner-uses-for-wastes-and-biomass-using-gasification>

⁸² CEG (2017) "The CEG Torrefaction Production Line", available at: <http://cegeneration.com/technology.html>

⁸³ ETI (2017) "Work starts on ETI backed innovative Waste Gasification Commercial Demonstration Plant in the West Midlands", <http://www.eti.co.uk/news/work-starts-on-eti-backed-innovative-waste-gasification-commercial-demonstration-plant-in-the-west-midlands>

gasification combined cycle (IGCC) plants, none of which have been developed in the UK. UK experience in gas turbine technology is only tangential via the likes of Rolls Royce (who sold their energy business to Siemens in 2014⁸⁴). Fife Energy proposed modifying an existing natural gas CCGT to use waste/coal syngas in in the early 2000s, but this did not happen. Air Product's Tees Valley projects (both 50MW_e) also built up some UK capabilities in the construction of (open cycle) syngas turbines, but as both plants failed to be commissioned, there is no UK operational expertise. Similarly, the ARBRE plant had a CCGT using biomass-derived syngas, but failed to operate for more than a few hours after starting up in 2001.

7.2 Chains

With the technology specific context provided above, the following sections now focus on the whole chain, from feedstock to end vector. Key chain issues arising from the combination of technologies, and the benefits of upstream pre-processing on the conversion technology are discussed. Supply chain barriers and risks are identified, before exploring potential deployment opportunities within the UK.

Common to all Chains 1-10 is the supply chain risk that sufficient volumes of the TEABPP feedstocks might not be planted in time (several years/decades ahead) to meet the demands of an expanding sector, even if market-based policies were supportive. This “chicken and egg” barrier is due to local farmers or foresters wanting to see secure demand with strong contracts (and the downstream plants built and operating) before they invest significant sums in establishing perennial energy crops or SRF, having learnt from prior bad experiences. This is particularly problematic for SRF, given the near impossible task of attempting to forecast biomass heating or power demands 20 years in the future (when a newly planted area today could become available to harvest).

7.2.1 Chain 1 – Underfeed stoker combustion boiler with screening

As a reminder from Figure 4.1, Chain 1 comprises feedstock harvesting and collection, screening (which includes an initial chipping step), natural drying of chips during shed storage, then truck transport to a local-scale underfeed stoker boiler (generating heat).

Key technical issues and benefits of combining technologies within the chain

Screening provides some benefits to underfeed stoker boilers, by improving the Particle Size Distribution (PSD) and therefore boiler availability (by reducing blockages and improving combustion uniformity)⁸⁵. However, screening only removes a limited proportion of the soil & stone contamination, and has no impact on the inherent chemical characteristics of the biomass, hence ash content at the boiler can still be elevated (particularly for perennial energy crops), leading to lower availability and higher operating costs than if cleaner feedstocks were used.

SRF logs have an advantage in potentially picking up much lower levels of contamination than perennial energy crops to start with, so screening has fewer benefits. However, several months of

⁸⁴ Rolls Royce (2014) “Rolls-Royce completes deal to sell its energy gas turbine and compressor business to Siemens”, available at: <https://www.rolls-royce.com/media/press-releases/yr-2014/pr-011214b.aspx>

⁸⁵ Note that in the TEABPP modelling, screening ensures the maximum particle size fits with the underfeed stoker specifications (avoiding a limit exceedance warning flag being raised in gPROMS), but the Particle Size Distribution (PSD) and its impact on boiler operation (i.e. detailed process engineering) is not modelled.

storage are generally required for wetter SRF feedstocks in order to dry them enough to meet the boiler specifications.

Short transport distances keep truck costs low in both Chains 1 and 2, but loading and unloading times and small load sizes mean that the majority of the transport costs in both Chains are static overheads, which are hard to reduce.

Supply chain risks and barriers

Not many farms have on-site screening and biomass storage infrastructure (for which the footprint required per farm in the base case is ~1 ha). This will be less of an issue for forestry managers whose supply chains already typically rely on these screening and storage steps.

The addition of small-scale screening equipment slightly increases overall capital cost of the chain and may reduce profitability – particularly if the screening equipment is only run for a limited number of hours a year (e.g. to coincide with Miscanthus or SRC willow harvesting windows).

Biomass yields vary between years, and small-user heating demands can vary significantly (with colder/warmer winters). If local fields/forests cannot produce the right quantity of biomass each year, users will have to buy in more expensive biomass from further afield, or farmers/forestry owners may have to pay to truck their excess biomass further afield to other users.

Miscanthus and SRC willow harvesting typically occurs between January and April, whereas SRF harvesting can happen year round⁸⁶. After harvesting, SRF and SRC willow also need a few months storage to dry out before use, whereas Miscanthus will generally be dry enough to use straight after baling (weather permitting). However, winter peak heating demands in the UK are typically found between November and March, so boilers in the late autumn/early winter months are likely to have to rely on only SRF or on perennial energy crops that have been stored for ~9 months since harvesting (this mismatch in timings increases storage losses and costs, particularly for SRC willow).

UK deployment opportunities

There are thousands of underfeed stoker boilers already installed across the UK, and a large number of these already buy on-specification (long rotation) wood fuel chips from suppliers that will have been through a screening step. The RHI will also continue to support more biomass boiler installations in the next few years. However, UK experience with SRF, SRC and Miscanthus is much more limited. There may only be a couple of dozen underfeed stoker boilers currently using Miscanthus or SRC willow chips in the UK, the vast majority of which will source from their own or local fields, which may or may not have been through a screening step⁸⁷. The absence of SRF areas in the UK means the TEABPP consortium is not aware of any existing SRF to heating supply chains.

Although most screening vendors in UK are based in Scandinavia or mainland Europe, and many biomass boiler manufacturers are Austrian, there could be opportunities to build upon the existing forestry, screening and boiler supply chains in the UK by supplementing with one of the TEABPP feedstocks (Miscanthus, SRC willow or SRF) where this is grown locally and boiler specifications

⁸⁶ Note that seasonality are not explicitly modelled in TEABP, for example there are no heating or power demand profiles. Base case storage times are given to be representative of what might be a credible UK average, as agreed with ETI and its experts, and the sensitivity analysis then looks at the impact of the full range of storage times (from zero storage up to several years)

⁸⁷ ETI (2014) “Annex 1: List of farmers self-supplying with Miscanthus”, part of the evidence pack assembled by Crops 4 Energy and E4tech for the ETI’s submission to the Biomass Suppliers List

allow. Alternatively, existing screening equipment could be better utilised (or shared between farmers when harvesting) with the new feedstocks to supply new boilers and heating demands.

With a small number of screening and underfeed stoker companies based in or with a presence in the UK, and equipment readily available from other companies operating worldwide, it would not be difficult to source equipment to implement this chain.

7.2.2 Chain 2 – Underfeed stoker combustion boiler with screening and field washing

As a reminder from Figure 4.3, Chain 2 comprises feedstock harvesting and collection, screening (which includes an initial chipping step), field washing, natural drying of chips during shed storage, then truck transport to a local-scale underfeed stoker boiler (generating heat).

Key technical issues and benefits of combining technologies within the chain

As above for Chain 1, screening improves the particle size distribution and ensures the maximum particle size is compliant with the boiler design. However, in Chain 2, the field wash step then removes all of the remaining soil & stone contamination, lowering the biomass ash content at the boiler, leading to improved availability and lower operating costs. Field washing is also likely to reduce the (highly water-soluble) halide content of the biomass, thereby reducing corrosion of the boiler and flue gas surfaces, also leading to improved availability and lower operating costs. However, the ability of field washing to remove a significant amount of alkali metals (reducing boiler fouling and availability) is not yet clear. Disposal of the waste water is unlikely to present a significant challenge for field washing, since the return of water, soil and stones and some halides to the same fields/areas they were extracted from is unlikely to be problematic (and could be beneficial to future biomass growth).

Field washing has much less benefit for cleaner SRF chains, as these start by picking up much lower levels of soil & stone contamination (with log harvesting), and generally have much lower halide contents.

Key issues with the implementation of this chain are likely to be the strictly limited feedstock moisture content that can be tolerated by the underfeed stoker boiler. Field washing at small-scale is unlikely to allow precise control of feedstock moisture content, and always will add moisture (thereby lowering the biomass LHV). In order to avoid lower boiler heating efficiencies than in Chain 1, the biomass then either needs to be forced dried (which is expensive), or as modelled in Chain 2, needs sufficient storage to allow natural drying (although this comes with higher degradation rates, due to the higher moisture content and high surface area of the stored biomass). Although not modelled as the Chain 2 base case, if the biomass were to remain wetter than in Chain 1 at the boiler (e.g. due to Chain 2 storage times being shortened), then boiler efficiencies will be lower, peak output will be lower (as higher residence times for burn out are needed), and the biomass will be more likely to clump together (leading to increased bridging in the boiler feed), leading to a higher risk of stoppages.

Supply chain risks and barriers

Several of the risks and barriers are shared with Chain 1, including the availability of on-farm areas (whereby field washing will further increase the footprint required), the addition of further capital costs (with both screening and field washing being run at a limited number of hours a year), plus the need to balance supply and demand.

In terms of the match between harvest windows and peak heating demands, the addition of field washing means that additional storage is generally required afterwards to remove the extra moisture content, which adds further pressure on the winter harvesting of Miscanthus or SRC willow to be able to meet that year's heating demands. This means that the perennial energy crops in Chain 2 are more likely to have to wait until the next winter to be consumed, although this is not as much of an issue for SRF feedstocks.

UK deployment opportunities

As discussed in Chain 1, a number of UK underfeed boiler operators buy on-specification (long rotation) wood fuel chips, but UK experience is limited with the TEABPP feedstocks. This is particularly true for Chain 2, where there are only thought to have been a handful of past trials with field washing, and some applicable learnings from the forthcoming ETI demonstrator (which is more focused on larger-scale, more sophisticated washing techniques).

There could be opportunities to build upon the existing forestry, screening and boiler supply chains in the UK by supplementing with one of the TEABPP feedstocks where this is grown locally – particularly if field washing enables a TEABPP feedstock to meet boiler limits that screening alone cannot achieve (although the base case warning flags do not support this). The RHI will also continue to support more biomass boiler installations in the next few years.

Significantly tighter boiler emissions requirements could drive uptake of field washing if boiler manufacturers are unable to make cost-effective design or flue gas clean-up changes, since lower ash biomass will typically lower boiler PM emissions⁸⁸. Field washing followed by sufficient natural drying is not expected to have a significant impact on biomass N content (other than potentially some small reductions due to less soil contamination), so there is unlikely to be a major benefit for boiler NO_x emissions. If there is insufficient natural drying, the higher moisture content would likely lower boiler NO_x emissions, but significantly increase CO and PM emissions.

Whilst field washing equipment can be bought at small scales to match local underfeed stoker supply chains, experience of field washing of biomass is very limited in the UK, so there are very limited opportunities to better utilise existing screening and field wash equipment to supply new boilers. For field washing companies to optimise and market their equipment for biomass washing instead of arable crops, they would need to see a market that was large and secure enough to make it worth their while, and have sufficient resources and market knowledge of the biomass sector. However, with a small number of screening and underfeed stoker companies based in or with a presence in the UK, and growth expected under the RHI, plus equipment readily available from other companies operating worldwide, it would not be difficult to source equipment to implement this chain.

7.2.3 Chain 3 – BFB gasifier + syngas engine with screening

As a reminder from Figure 4.5, Chain 3 comprises feedstock harvesting and collection, natural drying during on-farm shed storage/tarp storage in-forest, screening (which includes an initial chipping step), followed by large truck transport to an intermediate scale BFB gasifier + syngas engine (generating power).

⁸⁸ Duong (2012) "Characteristics of Biomass Combustion Emissions", Available at: <http://bioenergy.psu.edu/shortcourses/2012EmissionsHealth/Penn%20State%20Presentation%20R2.pdf>

Key technical issues and benefits of combining technologies within the chain

Screening of feedstocks improves the Particle Size Distribution (PSD), which has a series of small benefits for BFB gasifiers in terms of improved BFB management and control. This is due to removing oversize particles (thereby maintaining consistent fluidisation in the bed and reducing bridging/downtime in the BFB feed systems), and avoiding fines (thereby reducing the carry over and improving the cycle efficiency). However, of all the TEABPP conversion systems, BFB gasifiers are probably the most flexible to particle sizes and inhomogeneous feedstocks, and hence the benefits of screening are the smallest of any of the conversion technologies examined.

The syngas specifications required by the gas engine are less strict than those of gas turbines, so integration of these technologies is not anticipated to be problematic. The smaller footprint, lower cost and complexity of a syngas engine when compared to the currently deployed steam cycles are also promising.

As in Chain 1, screening only removes a limited proportion of the soil & stone contamination, and has no impact on the inherent chemical characteristics of the biomass. Ash content at the gasifier and any heat transfer surfaces can therefore still be elevated (particularly for perennial energy crops), leading to lower availability and higher operating costs due to fouling and slagging, and result in syngas with a higher PM content that requires more clean-up before the engine. Although SRF logs might have lower contamination levels, they require significant storage time to dry out naturally after harvesting (up to 2 years), in order to naturally dry down to about 20% moisture content.

Chain 3 has an advantage over Chain 4 in that only one transport step is modelled, straight from the farm/forest to the end user, whereas Chain 4 aggregates to a central point for pre-processing before further distribution. A modest distance in a larger scale truck allows for more efficient logistics optimisation, and fewer overheads.

Supply chain risks and barriers

Some of the risks and barriers are shared with Chain 1, including the availability of on-farm areas for screening and storage, the slight addition of capital costs (with screening only being run at a limited number of hours a year). The significant storage time (1-2 years) for drying out SRF logs also requires a large storage area in forest, although this is something the forest owners will be set up to do. However, the long time between SRF harvest and consumption could add some constraints on contracts, and adds to the upfront investment costs in supply chain infrastructure.

However, the supply barrier of having to balance local supply with local demands is reduced, as the BFB plant is a larger unit taking in biomass from a wider radius, and is well suited to using a variety of feedstocks. The focus on generating electricity also removes the pressure for the energy crop harvest window to match the local heating demand peak, as the BFB plant is likely to be operating on a much higher number of hours per year (closer to power grid baseload). This again allows a mix of perennial energy crops to be used shortly after harvesting, or SRF chips after seasoning, across the year.

The main challenge to deployment in the UK is likely to be the limited number of companies active in gasification and syngas engines, and the limited experience of both investors and EPC contractors in these technologies (and the intermediate syngas clean-up steps), hence a high perception of risk – gasification to steam cycle plants are generally seen as risky enough investments. Finding an EPC

with sufficient experience and appetite could be challenging, and the premium charged could be high⁸⁹ to mitigate the construction risk, which again would make financing more difficult.

The majority of UK gasification projects currently are also focusing on wastes, in order for the gate fee to offset the high capital costs. By using short rotation forestry or perennial energy crops, the delivered cost of power will be very high, as evidenced in Section 4.3. This makes projects using only these cleaner biomass sources less profitable than with wastes (if any profit at all is possible, with the current market-based subsidies available), and much more difficult to finance.

UK deployment opportunities

As discussed in Section 7.1.10, UK experience with BFB gasification and syngas engines is relatively limited. There are a number of projects in planning or construction, but mostly focused on wastes, due to the gate fees, or focusing on steam cycle turbines. The earliest opportunity to test new SRF or perennial energy crop feedstocks with a BFB gasifier + syngas engine system is likely to be the ETI funded gasification project, provided it did not focus exclusively on wastes. However, the commercial success of the conversion technology, and hence future opportunities to deploy this conversion technology with the TEABPP feedstocks, remains to be proven.

There could also be some local opportunities to better utilise existing screening equipment (or for sharing of equipment between farmers when harvesting) with the new TEABPP feedstocks to supply new BFB plants.

7.2.4 Chain 4 – BFB gasifier + syngas engine with water washing and pelleting

As a reminder from Figure 4.7, Chain 4 comprises feedstock harvesting and collection, natural drying during on-farm shed storage/tarp storage in-forest, small truck transport to a water washing plant (which includes initial chipping and screening steps), natural drying of chips in a warehouse, then pelleting onsite before large truck transport to an intermediate scale BFB gasifier + syngas engine (generating power).

Key technical issues and benefits of combining technologies within the chain

The feed into the BFB gasifier is considerably improved compared with Chain 3, as the BFB gasifier in Chain 4 uses highly uniform, dry, high LHV pellets that are guaranteed to be within the gasifier physical property limits, rather than screened chips (at higher moisture contents and lower LHVs). This will result in operational benefits to the BFB gasifier in terms of efficiencies, opex and availabilities, including more consistent LHV syngas, which improves system control.

However, compared to Chain 3 which only removes a fraction of the soil & stone contamination and has no inherent ash content changes, in Chain 4, the water washing step removes all of the contamination, along with some of the inherent ash content. Water washing is also likely to significantly reduce the (highly water-soluble) halide⁹⁰ and sulphur content of the biomass, thereby

⁸⁹ One interviewee involved in UK gasification project development recently estimated that EPC costs currently might add 40% on top of plant capex, compared with the 15-20% commonly charged for established technologies. This interview was part of the ongoing E4tech (2017) "Innovation Needs Assessment for Biomass Heat" project for BEIS, covering biohydrogen, bioSNG, AD pre-treatment, pre-processing technologies and perennial energy crops (as yet unpublished)

⁹⁰ HCl emissions from each conversion technology are not explicitly modelled in the TEABPP project. TEABPP only assumes enough lime is consumed to bring HCl emissions within emission limits, with a generic formula linking the feedstock chlorine content to the HCl production and hence lime consumption, as specified in the D3 report. This formula therefore already captures the abatement cost, and can be used as a proxy for the emissions cost should it be needed to be estimated.

reducing corrosion of the gasification plant surfaces, and will also reduce the alkali metals present, thereby reducing fouling. All these benefits lead to improved gasifier availability and lower operating costs. These benefits are highest for the least clean feedstocks (e.g. Miscanthus), and lowest for the cleanest feedstocks (e.g. SRF).

The disposal of chemically contaminated waste water is more challenging than disposal of the waste water from field washing. Although some waste water treatment is modelled, depending on the local permit requirements, water washing operators might need to spend further sums on waste water treatment or need further innovation/technology development to prevent this being a barrier to the development of the technology.

The bulk storage of wet chips in a warehouse after water washing, whilst they undergo natural drying, is likely to be relatively inefficient (given the volume of large chip piles and natural air flows). Whilst safety and practicality are not explicitly modelled within TEABPP, large piles of wetted chips are at a higher risk of self-heating and spontaneous combustion than dry piles – although water washing only adds a modest amount to the input moisture contents. However, there is also a greater fire risk when storing materials with different moisture contents together – this is an issue for Chain 4 given drier Miscanthus and wetter woody chips are assumed to be mixed during water washing.

The energy use in pelleting is a modest source of GHG emissions and efficiency losses. Water washing will always add moisture to the biomass, which will either require onsite storage to allow natural drying (as is modelled in Chain 4, with some degradation losses), or else would require additional biomass consumption for drying within the pelleting plant (to achieve the required mill moisture), further lowering the overall chain efficiency.

Although yet to be proven, integration of these technologies together in a single supply chain is not anticipated to be problematic, as the resulting pellets are likely to be cleaner than conventional forestry pellets, given their initial washing step. This should facilitate both downstream gasification and should produce higher-purity syngas which is more effective in a syngas engine, or a syngas that is cheaper to clean-up to the required syngas engine specifications.

Supply chain risks and barriers

Several of the risks and barriers are shared with Chain 3. These include the significant storage time and space for drying out SRF logs, placing constraints on contracts, and adding to the upfront investment in SRF infrastructure. The larger conversion plant scale and focus on power also mean the barriers associated with balancing local biomass supply to demand, and harvesting timings are relatively small.

However, the main challenge remains the limited number of companies active in gasification and syngas engines, and the high risk nature of the investment. By using pellets, some handling and operational risks are reduced, but the added costs of water washing, warehouse storage and pelleting (and the extra efficiency losses) significantly add to the capital costs of the supply chain, making the overall chain even more difficult to finance.

The centralised pre-processing plant avoids the need for on-farm/in-forest areas for screening before biomass collection – but the centralised point needs sufficient footprint in one place (and industrial land costs are higher than rural land costs). Although transporting pellets is cheaper than transporting chips per km, the increased total transport distance in Chain 4 (30 + 50km) due to the assumed aggregation at the pre-processing plant, compared to Chain 3 (50km direct to the BFB

gasifier) negates this benefit. The base case transport distances are still relatively low when supplying (~5MW_e) town-scale plants in Chain 4, and unlikely to be far enough for the benefits of pelleting pay off based on transport density alone.

In comparison with Chains 1-3, this is now a relatively complex supply chain, with 2 storage steps, 2 transport steps and 2 pre-processing steps, and coordinating the different actors and constructing upstream facilities to come online at the same time to feed a BFB plant will be challenging – as well as maintaining profitability over time of the different actors across the supply chain. The two pre-processing plants may be able to share labour for operations (e.g. if the same firm), which would be an opportunity to reduce costs.

One concern for Chain 4, as raised in the spider charts, is that the base case GHG emissions for Chain 4 are relatively high. Although Chain 4 would comfortably comply with the current RO GHG threshold, all new and existing plants will still have to comply with the tighter limits after 2020 and again after 2025, and the base case GHG emissions (with the current UK grid GHG intensity) would only just comply. This could therefore limit the Chain 4 supply chain options available (i.e. force large, efficient BFB plants to be built, with minimal transport distances, sourcing only low emission feedstocks and processes), which could be a barrier to deployment.

UK deployment opportunities

As discussed in Chain 3, UK experience with BFB gasification and syngas engines is relatively limited, and global experience with water washing of biomass is very limited. Until the ETI washing demonstrator programme is complete (only doing combustion testing), and the ETI funded gasification programme is completed (focus on wastes, not washed biomass), there will very likely not be any UK opportunities to test water washed chips or pellets in a BFB gasifier + syngas engine (the whole Chain 4 supply chain). The commercial success of each of the component technologies (e.g. water washing for combustion, and waste BFB gasification to syngas engines) remains to be proven, and hence the future opportunity to deploy BFB technology with the clean TEABPP feedstocks is unclear, and appears to be at least one further step removed from potential commercialisation compared to Chain 3.

Water washing could find its first markets in cleaning up biomass for combustion facilities, rather than gasification, given the number and scale of facilities, plus the current gasification plant focus on MSW/RDF. This could focus first on waste wood where element contaminant levels are much higher than the clean TEABPP feedstocks (and gate fees are possible), and therefore the extra costs of pre-processing are paid back faster.

There are existing UK pellet mills which could potentially install water washing onsite as a lower capex route to achieve the upstream steps in Chain 4 (including Drax's Miscanthus & straw pellet mill at Goole). However, for new pelleting plants, most vendors for pelleting equipment are based in Scandinavia or mainland Europe, so there is not a major opportunity for this section of the supply chain to support UK actors.

In the event that UK gaseous emissions requirements for medium-scale conversion plants become more stringent (further limiting the release of CO, unburnt hydrocarbons, PM, halides or sulphur compounds), water washing and pelleting may become more justified to achieve a cleaner, more uniform feedstock. However, for water washing companies to optimise and market their equipment for biomass water washing instead of arable crops, they would need to see a market that was large

and secure enough to make it worth their while, and have sufficient resources and market knowledge of the biomass sector.

7.2.5 Chain 5 – CFB combustion boiler with screening

As a reminder from Figure 4.9, Chain 5 comprises feedstock harvesting and collection, natural drying during on-farm shed storage/tarp storage in-forest, small truck transport to a screening plant (includes an initial chipping step), storage of chips in a warehouse, then large truck transport to a large-scale CFB combustion plant (generating power).

Key technical issues and benefits of combining technologies within the chain

Similar to Chain 3, screening of feedstocks improves the Particle Size Distribution (PSD), which has a series of small benefits for CFB combustion in terms of improved management and control, due to reduction in fines and oversized material. However, CFB combustion systems are tolerant to a fairly wide range of particle sizes, and hence the benefits of screening are small. There are no particular issues with steam cycle integration, as this is well proven.

As in Chain 1, screening only removes a limited proportion of the soil & stone contamination, and has no impact on the inherent chemical characteristics of the biomass, so ash content at the boiler can still be elevated (particularly for perennial energy crops), leading to lower availability and higher operating costs. Although SRF logs might have lower contamination levels, they require significant storage time to dry out naturally after harvesting (up to 2 years), in order to naturally dry down to about 20% moisture content.

Although the large transport distance adds costs, the use of a large scale truck allows for efficient logistics optimisation, and smaller relative overheads compared to Chains 1 to 4. Although Chains 5, 6 and 7 all use feedstock aggregation and the same transport distances, Chain 5 is transporting chips, and therefore using considerably more trucks to move the same MWh of biomass, which increases cost, logistical complexity, and GHG emissions.

Supply chain risks and barriers

Several of the risks and barriers are shared with Chains 3 and 4. These include the significant storage time and space for drying out SRF logs, and the slight addition of capital costs with the warehouse storage. The centralised screening plant will be run for a significant number of hours a year (unlike Chains 1–3), and avoids the need for on-farm/in-forest areas for screening before biomass collection, but the centralised plant needs sufficient footprint in one place.

The large-scale of the power plant (>100 MW_e) means feedstocks will be brought in from within a large radius, and potentially include access to imported feedstocks to supplement supplies, reducing the barriers and adverse impacts of local supply/demand balances and seasonal harvesting. However, ensuring stable feedstock supply chains with adequate storage of the different feedstocks to mitigate the risk of periodic low supplies will still be challenging, and take time to establish.

Whilst the limited number of UK actors active in CFB combustion might be a barrier, the technology is commercially available with performance guarantees, and there are already other large plants in Europe, so the technology risk is not particularly high. The difficulty in raising finance relates more to the scale of the investment (hundreds of millions), and the lack of further policy support available in the UK for large-scale biomass power plants (including Brexit uncertainties as to whether proposed EU RED II rules to 2030 will still apply).

UK deployment opportunities

There is only one CFB biomass combustion plant operating in the UK, the 50 MW_e Markinch plant in Fife. This was built for CHP operation, but is now power only with the closure of the onsite pulp mill, and is still looking for new heat customers⁹¹. The plant uses mostly waste wood chips, with some upstream chipping of virgin forestry logs. The 299 MW_e MGT Teesside plant is currently under construction, with a CfD contract, and will use a mix of imported chips and pellets (potentially with some local UK biomass), with plans to use waste heat for biomass drying⁹². The Orthios plant in Anglesey is at a similar scale, with a variety of CHP uses, but does not have a CfD contract and is still in planning⁹³. There are also a large number of past UK projects that were abandoned with subsidy changes. Given the volumes of biomass involved, all these supply chains may have a screening step before use, but no information is available.

There are no direct UK suppliers of CFB boilers, although there are suppliers active in the UK that could supply the technology. The screening suppliers could be as discussed in Chain 1. There is very limited opportunity for new biomass CFB combustion plants in the UK, due to the lack of opportunities for the installation of large plants (>100MW_e) to achieve commercial viability. Future policy changes are limiting options further, with the proposed EU RED II rules forbidding public support for new >20MW_e biomass power-only stations after 2020. This will require new plants to be combined heat and power systems with large local heat users (particularly challenging in the UK given the relative lack of district heating), and achieving a high overall efficiency threshold⁹⁴.

7.2.6 Chain 6 – CFB combustion boiler with pelleting

As a reminder from Figure 4.11, Chain 6 comprises feedstock harvesting and collection, natural drying during on-farm shed storage/tarp storage in-forest, small truck transport to a pelleting plant (which includes initial chipping and screening steps), pellet storage in a silo, then large truck transport to a large-scale CFB combustion plant (generating power).

Key technical issues and benefits of combining technologies within the chain

The feed into the CFB combustor is improved compared to Chain 5, as the CFB plant in Chain 6 uses highly uniform, dry, high LHV pellets that are guaranteed to be within the physical property limits, rather than screened chips (at higher moisture contents and lower LHVs). This will result in operational benefits to the CFB plant in terms of efficiencies, opex and availabilities, and potentially better control of plant gaseous emissions.

However, a proportion of the soil and stone contamination will make it into the biomass pellets, as although the pelleting plant includes initial chipping and screening steps, these will only be as effective as the centralised chipping and screening used in Chain 5. There will therefore not be any benefits from improved biomass chemical characteristics in Chain 6 compared to Chain 5, and ash contents will remain slightly elevated, particularly for Miscanthus.

⁹¹ RWE (2015) "Markinch CHP biomass plant", available at: <http://www.rwe.com/web/cms/en/429434/rwe-generation-se/fuels/location-overview/uk/markinch-chp-biomass-plant/>

⁹² MGT Teesside <http://www.mgtteesside.co.uk/> (accessed 24th August 2017)

⁹³ Orthios <http://www.orthios.com/index.php/locations/holyhead-eco-park> (accessed 24th August 2017)

⁹⁴ European Commission (2016) "Proposal for a DIRECTIVE OF THE EUROPEAN PARLIAMENT AND OF THE COUNCIL on the promotion of the use of energy from renewable sources (recast)", available at: http://ec.europa.eu/energy/sites/ener/files/documents/1_en_act_part1_v7_1.pdf

The energy use in pelleting is a modest source of GHG emissions and efficiency losses, and the biomass consumption for drying within the pelleting plant (to achieve the required mill moisture) lowers the overall chain efficiency.

Similar to Chain 5, SRF log drying time will be significant. However, the large transport distances in a large truck will be significantly cheaper and lower GHG emissions for pellets than chips in Chain 5.

Supply chain risks and barriers

Several of the risks and barriers are shared with Chain 5. These include the significant storage time and space for drying out SRF logs, although the centralised pre-processing point avoids the need for on-farm/in-forest areas for pre-processing before biomass collection. The large CFB plant allows a variety of biomass sources to be used, reducing the barriers of local supply/demand balances and seasonal harvesting – although ensuring stable feedstock supply chains with adequate storage of the different feedstocks to mitigate the risk of periodic low supplies will still be challenging, and take time to establish.

However, despite the technical maturity, the limited number of UK actors and difficulty in raising finance (due to lack of policy support) remains the key barrier to development of Chain 6.

The main differences to Chain 5 are that the centralised pre-processing step has a larger footprint requirement (pelleting vs. screening), and there are significant capital costs added to the chain due to pelleting and silo storage, which raises barriers about financing new upstream infrastructure at the same time as developing a new CFB plant.

UK deployment opportunities

As explained in Chain 5, there is only 1 operating biomass CFB plant in the UK (Markinch), 1 in construction (MGT), and 1 in planning (Orthios). There is very limited opportunity for new biomass CFB combustion plants in the UK, because of the current lack of support for large-scale dedicated biomass power plants, and uncertainty over future policy changes.

The MGT Teesside plant is planning on using large volumes of imported pellets, due to its scale. It is not yet clear whether existing UK forestry supply chains and pellet mills will be used to supply MGT Teesside, or whether they will only focus on using UK chips. However, better utilising or expanding existing UK pellet mills (including Drax's Miscanthus & straw pellet mill at Goole) could be an opportunity for supplying new CFB plants without investing very high sums in upstream investment costs, were local sources of energy crops or SRF available for pelleting. For new pelleting plants, most vendors for pelleting equipment are based in Scandinavia or mainland Europe, so there is not a major opportunity for this section of the supply chain to support UK actors.

7.2.7 Chain 7 – CFB combustion boiler with chemical washing and pelleting

As a reminder from Figure 4.13, Chain 7 comprises feedstock harvesting and collection, natural drying during on-farm shed storage/tarp storage in-forest, small truck transport to a chemical washing plant (which includes initial chipping and screening steps), natural drying of chips in a warehouse, then pelleting and pellet silo storage, before large truck transport to a large-scale CFB combustion plant (generating power).

Key technical issues and benefits of combining technologies within the chain

As in Chain 6, the feed into the CFB combustor is improved compared to Chain 5, as the CFB plant in Chain 7 uses highly uniform, dry, high LHV pellets that are guaranteed to be within the physical property limits. This will result in operational benefits to the CFB plant.

However, compared to Chains 5 or 6 only removing a fraction of the soil & stone contamination and no inherent ash content changes, in Chain 7, the chemical washing step removes all of the contamination, and almost all of the inherent ash content, halides, alkali and other heavy metals, plus a majority of the biomass sulphur. All of these will significantly reduce corrosion and fouling in the CFB plant, leading to higher availabilities and lower operating costs. These benefits will be highest for the least clean feedstocks (e.g. Miscanthus), and lowest for the cleanest feedstocks (e.g. SRF). However, the major downside of chemical washing is likely to be an increase in biomass nitrogen content (due to the ammonium acetate alkali solution used)⁹⁵, which will either significantly increase CFB urea use or NO_x emissions.

Although far from being proven, the integration of these technologies together in a single supply chain is likely to be technical feasible, as the resulting washed pellets are likely to generally be much cleaner than conventional forestry pellets (with the potential exception of the nitrogen content).

The disposal of highly chemically contaminated waste water will be significantly more challenging than disposal of the waste water from either water washing or field washing. Although some waste water treatment is modelled, depending on the local permit requirements, chemical washing operators might need to spend significantly larger sums on waste water treatment or need further innovation/technology development to prevent this being a barrier to the development of the technology.

Similar to Chain 4, the bulk storage of wet chips in a warehouse after chemical washing, whilst they undergo natural drying, is likely to be relatively inefficient. Large piles of very wet chips (given the expected soaking during chemical washing) are at a much higher risk of self-heating and spontaneous combustion than dry piles. The fire risk of storing materials with different moisture contents together is somewhat reduced in Chain 7, as the both the Miscanthus and woody feedstocks will exit chemical washing with similarly high moisture contents, and the output of every few days can be timed for storage in different piles around the warehouse.

Similar to Chain 3, the energy use in pelleting is a modest source of GHG emissions and efficiency losses. Chemical washing is always expected to add moisture to the biomass, which will either require onsite storage to allow natural drying (as is modelled in Chain 7, with some degradation losses), or else would require additional biomass consumption for drying within the pelleting plant (to achieve the required mill moisture), further lowering the overall chain efficiency.

Similar to Chain 5, SRF log drying time will be significant. However, the large transport distances in a large truck will be significantly cheaper and lower GHG emissions for pellets than chips in Chain 5.

Supply chain risks and barriers

Several of the risks and barriers are shared with Chain 6. These include the significant storage time and space for drying out SRF logs, the centralised pre-processing plant footprint, and the

⁹⁵ Gudka B., Jones J.M., Lea-Langton A.R., Williams A., Saddawi A. (2015) A review of the mitigation of deposition and emission problems during biomass combustion through washing pre-treatment. Journal of the Energy Institute, 89(2), 159-171

requirement to ensure stable supply chains with storage of different feedstocks to avoid low supplies at the large CFB plant. The limited number of UK actors and difficulty in raising finance (due to lack of policy support) remain the key barrier to development of Chain 7.

The main differences from Chains 5 and 6 are that the centralised pre-processing step in Chain 7 has an even larger footprint requirement (with the addition of chemical washing and a warehouse), which also comes with further significant capital costs, which raises significant barriers about financing new upstream infrastructure at the same time as developing a new CFB plant. There is also a significant risk that waste water disposal from chemical washing becomes a barrier to the adaptation of this technology.

While pelleting and CFB combustion are widely deployed technologies which operate today in the UK, chemical washing is still at early TRL and there is only limited academic activity and limited experience on testing with different UK feedstocks. Therefore given the likely significant amount of R&D and demonstration that is still required for chemical washing, Chain 7 is only likely to be deployed in the medium term, when equipment could be adapted from water washing.

Further R&D work will be required to research different alkali solutions that do not increase specific elemental contents, as the current impact of ammonium acetate on conversion plant NO_x emissions could be a significant barrier to deployment of the technology⁹⁵. By using a different alkali solution, the problem might be shifted away from nitrogen and onto a different element within the biomass – the trade-offs of whether the subsequent acid wash and water rinsing steps are able to remove this element, or the conversion technology deal with it, remain to be explored.

Chain 7 is the most complex supply chain within TEABPP, with 3 storage steps, 2 transport steps and 2 pre-processing steps. Coordinating the different actors and constructing upstream facilities to come online at the same time to feed a large CFB plant will be challenging – as well as maintaining profitability over time of the different actors across the supply chain. The two pre-processing plants may be able to share labour for operations (e.g. if the same firm), which would be an opportunity to reduce costs.

One significant concern for Chain 7, as raised in the spider charts, is that the base case GHG emissions for Chain 7 are relatively high. Although Chain 7 would likely comply with the current RO GHG threshold, all new and existing plants will still have to comply with the tighter limits after 2020 and again after 2025, and the base case GHG emissions (with the current UK grid GHG intensity) fail to comply with the 2025 threshold. This could therefore severely limit the Chain 7 supply chain options available (i.e. force large, efficient CFB plants to be built, with minimal transport distances sourcing only low emission feedstocks and processes), which could be a barrier to deployment – or else require additional time and effort to improve the material and energy consumption of the chemical washing and pelleting processes (and/or the feedstocks).

UK deployment opportunities

As in Chain 6, there is very limited opportunity for new biomass CFB combustion plants in the UK.

It will be at least a decade before chemical washing technology is available at scale, provided there is industry demand and the technology proves to be viable. If chemical washing is successfully developed in the mid-term, there are existing UK pellet mills which could install chemical washing onsite as a lower capex route to achieve the upstream steps in Chain 7. However, there are no chemical washing facilities today that could be repurposed or redirected. For new pelleting plants,

most vendors for pelleting equipment are based in Scandinavia or mainland Europe, so there is not a major opportunity for this section of the supply chain to support UK actors.

Demand for washing technologies is somewhat at odds with the industry trend towards ever drier and higher energy density products such as pellets and torrefied pellets. There is likely to be limited demand for washing cleaner virgin wood feedstocks that already have low mineral contents. Similar to water washing, chemical washing could find its first markets in cleaning up biomass for combustion facilities, rather than gasification (as it is unlikely to be able to accept MSW/RDF feedstocks). It could be used first on waste wood where element contaminant levels are much higher than the clean TEABPP feedstocks and gate fees are possible.

In the event that UK gaseous emissions requirements for large-scale conversion plants become more stringent (further limiting the release of CO, unburnt hydrocarbons, PM, halides or sulphur compounds), chemical washing and pelleting may become more justified to achieve a much cleaner, more uniform feedstock. However, given chemical washing (in its current configuration) is expected to increase biomass N content, it is not likely to be helpful in meeting plant NO_x emissions. For water washing companies (most likely to be future chemical washing companies) to optimise and market their equipment for biomass chemical washing, they would need to see a market that was large and secure enough to make it worth their while, and have sufficient resources and market knowledge of the biomass sector.

7.2.8 Chain 8 – EF gasifier + syngas CCGT with pelleting

As a reminder from Figure 4.15, Chain 8 comprises feedstock harvesting and collection, natural drying during on-farm shed storage/tarp storage in-forest, small truck transport to a pelleting plant (which includes initial chipping and screening steps), pellet storage in a silo, then large truck transport to a very large-scale EF gasifier + syngas CCGT (generating power).

Key technical issues and benefits of combining technologies within the chain

Using pellets ensures that the biomass has consistent physical parameters in the range required by the EF gasifier (size, moisture etc.), which helps with operational control, avoiding feeding issues, and maintaining a relatively consistent and high-quality syngas that meets the CCGT syngas specifications.

Similar to Chain 6, a proportion of the initial soil and stone contamination will make it into the biomass pellets, and since pelleting has no impact on the inherent chemical composition, the total biomass ash content will remain slightly elevated, particularly for Miscanthus.

The biggest technical issue facing Chain 8 is the large parasitic power load required to crush the incoming pellets down to sub-1mm particles required for EF gasifier injection, which has a fairly significant impact on the overall chain efficiency. The energy use within the pelleting step also remains a source of GHG emissions and efficiency losses, due to the biomass consumed for drying (to achieve the required mill moisture), and the mill's power consumption.

As in Chain 6, SRF log drying time will be significant, and the movement of pellets in a large truck with optimised logistics allows for the impact of the large transport distances to be minimised.

Supply chain risks and barriers

Several of the risks and barriers are shared with Chain 6. These include the significant storage time and space for drying out SRF logs, and the centralised pre-processing plant footprint.

There are significant capital costs added to the chain due to pelleting and silo storage, which makes financing new upstream infrastructure at the same time as developing a new large-scale conversion plant challenging. There are no technical barriers to pelleting in the UK, as it is a commercial technology which is already widely deployed here with many actors, albeit generally operating on a smaller scale than in the USA or Canada.

A critical barrier is the lack of UK experience with entrained flow gasification, which due to its large scale and feedstock requirements, is substantially different to other gasification technologies which have been implemented in the UK. Because EF gasifier technology is not yet proven with biomass or in the UK, investors are likely to perceive such developments as risky which, combined with the large scale of the project (typically 100's of MWs), will make securing investment severely challenging – even if policy support for power-only biomass plants were available. This will be compounded by the lack of UK experience and past UK failures in syngas turbine projects (including ARBRE and Tees Valley), and the added complexity of integrating EF gasifier and syngas CCGT technologies (with intermediate syngas clean-up steps) successfully. Finding an EPC with sufficient experience and appetite to build such a large and complex plant could also be challenging, and as in Chain 3, the premium charged is likely to be high to mitigate the construction risk, which again would make financing more difficult.

Due to the very large scale of entrained flow gasifiers, a variety of biomass sources could be used including imports, reducing the barriers of local supply/demand balances and seasonal harvesting. However, ensuring stable feedstock supply chains with adequate storage of the different feedstocks to mitigate the risk of periodic low supplies will take significant time to establish. Nevertheless, very large biomass supply chains have been established in the UK e.g. for Drax power station which produces ~2 GW of biomass electricity using imported pellets.

UK deployment opportunities

As discussed in Section 7.1.11 above, there are currently no developers of entrained flow gasification in the UK, and no UK deployment of syngas CCGTs. There are also no EF gasification projects in planning or construction in the UK, nor are there any new plans for syngas turbines or CCGTs. Therefore, opportunities for implementing this Chain 8 by using planned projects currently do not exist in the UK, and are unlikely to exist in the near term.

This might change in the future if biomass EF gasifiers (due their higher quality syngas) were deployed for city-scale hydrogen applications (feeding bio-hydrogen into the gas grid), or transport biofuel applications, but this could take several decades. It could also require further modification of the gas turbine to use hydrogen instead of syngas if by then the UK were then focused on bioenergy with carbon capture (i.e. large-scale carbon negative options) instead of biomass power/CHP generation alone.

If and when a biomass EF plant was established, better utilising or expanding existing UK pellet mills could be an opportunity for supplying new EF plants without investing very high sums in upstream investment costs, were local sources of energy crops or SRF grown for pelleting. For new pelleting

plants, most vendors for pelleting equipment are based in Scandinavia or mainland Europe, so there is not a major opportunity for this section of the supply chain to support UK actors.

7.2.9 Chain 9 – EF gasifier + syngas CCGT with torrefaction + pelleting

As a reminder from Figure 4.17, Chain 9 comprises feedstock harvesting and collection, natural drying during on-farm shed storage/tarp storage in-forest, small truck transport to a torrefaction + pelleting plant (which includes initial chipping and screening steps), torrefied pellet storage in a silo, then large truck transport to a very large-scale EF gasifier + syngas CCGT (generating power).

Key technical issues and benefits of combining technologies within the chain

As with Chain 8, using pellets ensures that the biomass has consistent physical parameters in the range required by the EF gasifier (size, moisture etc.), which helps with operational control, avoiding feeding issues, and maintaining a relatively consistent and high-quality syngas that meets the CCGT syngas specifications.

The biggest benefit of torrefied pellets to Chain 9 is the very significantly reduced parasitic power load required to grind the incoming pellets down to sub-1mm particles required for EF gasifier injection. Torrefied pellets also have lower moisture content (improving plant efficiency) and enhanced durability (with less dust/higher safety). As the properties of torrefied biomass more closely mimic coal, there are also opportunities to benefit from the operational learnings of already-commercial coal IGCC plants.

The possibility of storing torrefied pellets outdoors has been looked at in a number of studies. Whilst several torrefaction developers claim outdoor storage is possible due to enhanced moisture resistance and less degradation compared to white pellets, the studies concluded there are time limitations to outdoor storage depending on the initial pellet quality (e.g. sealed, glassy surfaces with few cracks do better), stack size and shape, and climate. Longer trials often had high moisture gains, disintegration issues, and fungal growth⁹⁶, so Chain 9 retained a pellet silo during its design.

However, producing torrefied pellets comes with added capital costs and efficiency losses upstream, as greater temperatures, more drying (burning more of the input biomass energy content, in the form of torrefaction gases) and more processes are needed than for just standard wood pelleting. Similar to Chain 8, not all of the extra ash added by the initial soil and stone contamination can be removed before pelleting, and furthermore, the torrefaction process drives off volatiles, meaning that the torrefied pellets typically have a slightly higher ash content than standard pellets. Torrefied pellets also have higher %s of other unwanted elements (apart from potentially halides), which act to reduce EF plant availability and increase operating costs, and potentially increase plant gaseous emissions.

As in Chain 8, SRF log drying time will be significant. The movement of torrefied pellets in a large truck (with optimised logistics) allows for the impact of the large transport distances to be minimised, and Chain 9 will have slightly lower transport costs and transport GHG emissions compared to Chain 8, due to the higher energy density of torrefied pellets compared to standard pellets.

⁹⁶ Danish Technology Institute (2015) “Best Practice Guideline – Storage and Handling of torrefied biomass”, available at: https://www.teknologisk.dk/_/media/64590_Storage%20and%20Handling%20of%20torrefied%20biomass.pdf (accessed 25/10/2017)

Supply chain risks and barriers

Several of the risks and barriers are shared with Chain 8. These include the significant storage time and space for drying out SRF logs, although the centralised pre-processing point avoids the need for on-farm/in-forest areas for pre-processing. However, the centralised torrefaction + pelleting step has a larger footprint requirement than in Chain 8, and there are very significant capital costs added to the chain due to torrefaction, pelleting and silo storage, which makes it challenging to finance new upstream infrastructure at the same time as developing a new large-scale conversion plant. Due to the very large scale of entrained flow gasifiers, a variety of biomass sources could be used including imports, and supply chains will take significant time to establish.

Torrefaction is at an early commercial stage for (long rotation) forestry and sawmill residues, and has yet to be demonstrated at scale on perennial energy crops or SRF, although both Miscanthus and willow have been successfully torrefied in small scale tests. This added technical risk presents a barrier to financing, particularly for Miscanthus facilities, which would be the least similar to forestry. Whether a binder is required (as is the case for standard pelleting of Miscanthus) is also yet to be determined. There are a few actors in the UK, but still relatively limited operational experience⁹⁷.

Torrefied fuels have a draft fuel specification (BS EN ISO 17225-8), which is in the process of being finalised, but torrefaction products are not yet fully standardised given the variety of different torrefaction concepts and reactor designs.

As in Chain 8, the critical barrier is the lack of UK experience with entrained flow gasification and with syngas CCGT, and the immaturity of this combined system using biomass. The construction premiums required by EPCs will be high, and the scale of investment required is large, meaning that investors will perceive compounded feedstock, technical and project risks, which will make financing very challenging.

UK deployment opportunities

As noted under chain 8, there are currently no developers of EF gasification in the UK, and no UK deployment of syngas CCGTs. There are also no EF gasifier projects operating, in construction or planning in the UK, hence opportunities for implementing this Chain 9 currently do not exist in the UK, and are unlikely to in the near or mid-term, given the additional development work required with torrefaction of the TEABPP feedstocks. As discussed in chain 8, this might change in a few decades if biomass EF gasifiers were deployed for city-scale hydrogen grid or transport biofuel applications.

The additional densification achieved through torrefaction + pelleting is likely to be most advantageous with biomass imported over long distances, and of less value for UK biomass chains. Were the business case for torrefaction to develop, some existing UK pellet mills could potentially convert to torrefaction + pelleting plants, although the changes required within the plant (adding, retrofitting and recalibrating equipment) plus additional space requirements could be significant. A standard pellet plant retrofit has already been carried out for steam explosion (which shares some

⁹⁷ Although Chain 9 is generating power, the process for getting torrefied pellets accepted by the Renewable Heat Incentive is instructive to the types of barriers new intermediate fuel types can face. Torrefied pellets were originally only recognised by the UK's Biomass Suppliers List (for RHI reporting) if they were wood-based, but other non-wood based materials (e.g. torrefied Miscanthus pellets) can now apply to the UK's Sustainable Fuel Register – i.e. this barrier took ~5 years to overcome for heating applications.

similarities with torrefaction) in the USA. However, for new torrefaction + pelleting plants, most vendors for pelleting equipment are based in mainland Europe. Most vendors for torrefaction plants are based in the USA (with limited experience in mainland Europe), so there is not a major opportunity for this section of the supply chain to support UK actors.

7.2.10 Chain 10 – EF gasifier + syngas CCGT with pyrolysis

As a reminder from Figure 4.19, Chain 10 comprises feedstock harvesting and collection, natural drying during on-farm shed storage/tarp storage in-forest, small truck transport to a pyrolysis plant (which includes an initial grinding step), pyrolysis oil storage in a tank, then large tanker transport to a very large-scale EF gasifier + syngas CCGT (generating power).

Key technical issues and benefits of combining technologies within the chain

The biggest benefit of pyrolysis oil to Chain 10 is the avoidance of a biomass milling step at the EF gasifier (avoiding the significant parasitic power load), as the oil can be easily pumped into the EF gasifier at high-pressure without a solids handling section. This also saves on EF gasifier capex, and avoids operational blockage issues. Pyrolysis oil is also expected to have significantly lower ash, halides, nitrogen, alkali metal and sulphur content compared to the original biomass feedstocks, as much of the unwanted contaminants are left in the solid biochar fraction. These feedstock improvements result in lower EF gasifier plant operating costs, higher availabilities and cleaner syngas, meaning reduced syngas clean-up requirements.

Producing pyrolysis oil adds significant added capital costs and very significant efficiency losses upstream in Chain 10, particularly if alkali metals are present in the original feedstocks, as these promote gas and solid fractions over liquid production (i.e. low yields are achieved). Pyrolysis oil also typically has a higher moisture content than pellets, which lowers EF gasifier efficiency, and is yet to be optimised for EF gasification or on TEABPP feedstocks, which raises risks over the consistency of the input oil and hence the consistent operation of the plant and syngas quality. Pyrolysis oil can also be extremely corrosive, which may cause problems in the gasifier, and necessitate pH adjustment of the oil to reduce its acidity. The pyrolysis process is expected to be mostly energy self-sufficient, but this relies on high levels of energy integration, and the combustion of pyrolysis gases and char which can be high in contaminants.

As in Chain 8, SRF log drying time will be significant. However, compared with Chain 8 and 9, the final transport step is moving dense pyrolysis oil by a liquid tanker. This might be slightly cheaper per tonne-km than trucking standard or torrefied pellets, but taking into account the moisture content of the pyrolysis oil, and the impact this moisture has on downstream efficiencies, the transport costs of moving bio-oil by tanker are modelled as being slightly higher per MWh-km than for trucking standard or torrefied pellets. However, moving pyrolysis oil is still much lower cost per tonne-km or per MWh-km than trucking chips or bales. It is for this reason that some developers envision a future with many distributed pyrolysis plants located near to the biomass resources⁹⁸, so that it is energy-dense pyrolysis oil, rather than low density chips or bales, that is transported to a large centralised gasifier. However, the base case and optimum case results from TEABPP do not support the view that multiple, small upstream pyrolysis plants make economic sense in the UK context when

⁹⁸ Bioliq (2016) "The Karlsruhe Bioliq process", available at: https://www.bioliq.de/downloads/Flyer%20als%20Datenblatt_EN_2016.pdf

supplying EF gasifier + syngas CCGT plants with the TEABPP feedstocks (the TEABPP model does not allow generalisations to straw in other countries to be made).

Supply chain risks and barriers

Several of the risks and barriers are shared with Chain 8. These include the significant storage time and space for drying out SRF logs, although the centralised pre-processing point avoids the need for on-farm/in-forest areas for pre-processing. However, the centralised pyrolysis step has a large footprint requirement, and there are significant capital costs added to the chain due to pyrolysis and tank storage, which makes financing new upstream infrastructure at the same time as developing a new large-scale conversion plant challenging.

Pyrolysis oil has been sold commercially to replace heating oil for industrial users for many years, but is only in the early stages of development as a pre-processing technology for biomass power and biofuel applications. Pyrolysis has been coupled with a ~5MW EF gasifier in the Bioliq pilot plant at the Karlsruhe Institute of Technology⁹⁹ in Germany, although this is focused on bioDME and biofuels production, not gas turbine power applications. Pyrolysis is yet to be proven at full commercial scale on perennial energy crops or SRF (although successfully tests have been done at smaller scales). This added technical risk presents a barrier to financing.

Although there are few existing pyrolysis oil producers in the UK, they are producing at only modest scales, and none have optimised their product properties for downstream conversion in an EF gasifier to high quality syngas. Therefore, securing sufficient volumes of high quality bio-oil in the UK is likely to be challenging.

Transport and storage of bio-oil is feasible (despite its corrosive and acidic nature), however, the UK is not experienced in handling or transporting bio-oil, so the necessary equipment or personnel may not be available and the oil may need to be stabilised.

As in Chain 8, the critical barrier is the lack of UK experience with entrained flow gasification and with syngas CCGT, and the immaturity of this combined system using biomass. The construction premiums required by EPCs will be high, and the scale of investment required is large, meaning that investors will perceive compounded technical and project risks, which will make financing very challenging.

UK deployment opportunities

There are no EF gasifiers or syngas CCGTs currently operational in the UK, and whilst there is UK activity in pyrolysis, it is not yet optimised for gasification applications or for the TEABPP feedstocks.

There is no evidence of the whole chain operating at above pilot scale anywhere globally, as either EF gasifier + CCGT plants are currently using coal or solid biomass, or pyrolysis plants are selling their bio-oil to combustion heating or transport biofuel applications.

Chain 10 relies on a combination of three technologies which are currently unproven in the UK (large-scale pyrolysis with cost-effective oil treatment, EF gasification, and syngas CCGT) – potentially four if you include SRF and perennial energy crops. Opportunities for implementing this chain currently do not exist in the UK, and are unlikely to in the near or mid-term, and so Chain 10 should be seen as a long-term rather than short-term priority.

⁹⁹ Bioliq (2016) The bioliq process, <https://www.bioliq.de/english/55.php>

The additional densification achieved through pyrolysis is likely to be most advantageous with biomass transported over long distances (given marginally cheaper per km transport costs than pellets). However, the benefits of a hub-and-spoke model of distributed pre-processing sites remains to be proven, particularly given that small pyrolysis units will have even higher levelised CAPEX. Were biomass EF gasifiers to be deployed for UK city-scale hydrogen grid applications in a few decades, some of the UK pyrolysis actors could better utilise or expand production at their existing (and future) UK pyrolysis plants, were local sources of energy crops or SRF available.

8 Recommendations

The key sensitivities, cross-over conditions and innovation improvements are finally combined with the qualitative assessment of the chains to provide recommendations for technology acceleration (in both the short and longer term) that will most improve the UK biomass chains assessed and likely lead to enhanced deployment.

8.1 Heat map summary of findings

First, the following “heat map” tables summarise the key information gathered during the TEABPP project, comparing chains within their groupings. Cell colours have been assigned, according to the following assessments for each of the following qualitative and quantitative criteria:

- Base case LCOE: Green = low; Amber = medium; Red = high (separate scales for heat and for power)
- Most sensitive parameters: Green = multiple options to significantly change results by intervention; Amber = some options; Red = very limited options, most results are immutable
- Cross-overs (only applies to the “with pre-processing” chains): Green = at least one clear LCOE cross-over; Amber = some unclear LCOE cross-overs; Red = no clear or unclear LCOE cross-overs
- Optimum case LCOE: Green = low; Amber = medium; Red = high (separate scales for heat and for power)
- Key innovations: Green = large improvement from the Base case LCOE; Amber = medium improvement; Red = little improvement
- TRL status: Green = components all at TRL 8-9, chain commercially available today; Amber = some components at TRL 6-7, or full chain only at demonstration scale today; Red = some components at TRL 5 or below, several decades before chain will have scaled up
- Warning flags raised: Green = no warning flags raised in gPROMS base case; Amber = few warning flags raised; Red = multiple warning flags raised, hence performance guarantees, lifetime or emissions at risk
- Technical issues: Green = no or minimal technical issues to resolve; Amber = few issues to resolve, or technology needs optimising to TEABPP feedstocks; Red = multiple, significant issues to resolve, requiring extensive R&D
- Technical benefits: Green = pre-processing significantly improves operation of the conversion technology; Amber = slightly improves operation, or has some negative impacts as well; Red = does not improve operation, or has multiple negative impacts
- UK actors: Green = several UK technology developers; Amber = few UK technology developers, or multiple foreign technology developers with a UK presence; Red = no UK technology developers and few or no foreign technology developers with a UK presence
- Barriers and risks: Green = chain has few obstacles to being widely deployed, and these are not serious or easily addressable; Amber = chain has several serious obstacles to being

widely deployed, but policy changes could address these; Red = chain has multiple very serious obstacles to being widely deployed, and policy changes unlikely to address these

- UK deployment opportunities: Green = strong fit, as the full supply chain already exists in the UK
Amber = medium fit, as some components of the supply chain already exist in the UK and could be expanded, retrofitted or repurposed; Red = poor fit, as no components of the supply chain exist in the UK

Intermediate colours have also been added, so that the ordering reads: **Dark green** (best), **light green**, **amber** (medium), **brown**, **bright red** (worst).

8.1.1 Chain 2 vs. Chain 1

As a reminder from Figure 4.1 and Figure 4.3, both Chains 1 and 2 comprise feedstock harvesting and collection, then screening (which includes an initial chipping step), followed by:

- Chain 1: natural drying of chips during shed storage, then truck transport to a local-scale underfeed stoker boiler (generating heat).
- Chain 2: **field washing**, natural drying of chips during shed storage, then truck transport to a local-scale underfeed stoker boiler (generating heat).

Table 8.1: Chain 2 vs. 1 quantitative and qualitative summary

| Criteria | Chain 1 | Chain 2 |
|---------------------------|--|--|
| Base Case LCOE | £53/MWh _{th} | £57/MWh _{th} |
| Most sensitive parameters | Miscanthus chip transport distance Boiler capacity Woody chip transport distance Woody screening capacity | Miscanthus chip transport distance Boiler capacity Woody chip transport distance Woody screening capacity |
| Cross-overs | NA | No single options, but most likely to find cross-overs when using Miscanthus |
| Optimum Case LCOE | £35/MWh _{th} | £36/MWh _{th} |
| Key innovations | Boiler CAPEX Boiler efficiency Boiler electricity use | Boiler CAPEX Boiler efficiency Boiler electricity use |
| TRL status | Screening: 9 Boiler: 9 | Screening: 9 Field wash: 7, less with energy crops Boiler: 9 |
| Warning flags raised | Ash, Al, N, Si, Cl, K, Na, Ca | Ash, Al, N, Si, Cl, K, Na, Ca |
| Technical issues | Ash still high, can be wet/low LHV | Wetter biomass or more storage needed |
| Technical benefits | Correct particle size | Less ash (so less PM), and less halides Correct particle size |
| UK actors | Screening: Saxlund, Vecoplan, Komptech Boiler: Hoval, Cochran, British Gas/Econergy, Rural Energy | Screening: Saxlund, Vecoplan, Komptech Field wash: unclear (CRL?), Uni of Leeds Boiler: Hoval, Cochran, British Gas/Econergy, Rural Energy |

| Criteria | Chain 1 | Chain 2 |
|------------------------------------|---|---|
| Barriers and risks | "Chicken and egg" for planting Storage area on-farm Annual supply/demand variability Winter harvest during heat peak | "Chicken and egg" for planting Storage area on-farm Annual supply/demand variability Storage may be needed until next year |
| UK deployment opportunities | 1000s boilers already, few use energy crops RHI still expanding, easy to implement, though will need specific boilers Share screening kit | 1000s boilers already, few use energy crops RHI still expanding, easy to implement, though will need specific boilers Share screening kit |

Chain 1 & 2 costs are dominated by factors unrelated to technical improvement or biomass chemical properties. There are no individual opportunities that enable Chain 2 cross-overs, although the value of field washing is highest when using high ash, highly soil contaminated feedstocks.

However, field washing is not currently able to sufficiently clean up the TEABPP feedstocks to comply with the given boiler specifications (based on the EN-A2 wood pellets standard), and multiple warning flags are still raised. This means perennial energy crops and SRF will still require burning in specifically designed boilers (as even SRF has too high ash, nitrogen and alkali metals contents for EN-A2). The only alternative would be using much more sophisticated washing to sufficiently clean the TEABPP feedstocks, but water or chemical washing would add very significant costs (as indicated by Chains 4 and 7) to these heat chains, and still may not remove all the contaminant flags (e.g. nitrogen). **Therefore at the moment field washing does not appear to offer significant enough benefits¹⁰⁰ to warrant further investigation by ETI.**

Implementation of field wash technology would be straight forward and the existing UK boiler market offers deployment opportunities (with some UK actors able to benefit). However, given the low costs and simplicity of the technology, the market might be expected to demand and rapidly deliver field washing technology (in <5 years) in the event it was required, without outside assistance.

8.1.2 Chain 4 vs. Chain 3

As a reminder from Figure 4.5 and Figure 4.7, both Chains 3 and 4 comprise feedstock harvesting and collection, natural drying during on-farm shed storage/tarp storage in-forest, followed by:

- Chain 3: screening (which includes an initial chipping step), followed by large truck transport to an intermediate scale BFB gasifier + syngas engine (generating power).
- Chain 4: small truck transport to a **water washing plant** (which includes initial chipping and screening steps), natural drying of chips in a warehouse, then pelleting onsite before large truck transport to an intermediate scale BFB gasifier + syngas engine (generating power).

¹⁰⁰ The only chains it could potentially remove all the remaining flags from could be Chains 8 and 9 (removing Chlorine and Bromine flags), and it could also help pyrolysis (lowering ash content to improve efficiencies). However, none of these options have been modelled, and EF gasifier development is only likely in the long-term, so this also does not appear to be a priority.

Table 8.2: Chain 4 vs. 3 quantitative and qualitative summary

| Criteria | Chain 3 | Chain 4 |
|-----------------------------|--|---|
| Base Case LCOE | £172/MWh _e | £197/MWh _e |
| Most sensitive parameters | BFB gasifier + syngas engine capacity Miscanthus chip transport distance | BFB gasifier + syngas engine capacity Miscanthus bales transport distance |
| Cross-overs | NA | Some options, but only if very wet, and very small screening. But pelleting only is better |
| Optimum Case LCOE | £75/MWh _e | £97/MWh _e |
| Key innovations | BFB gasifier CAPEX Syngas engine efficiency BFB gasifier efficiency | BFB gasifier CAPEX Syngas engine efficiency BFB gasifier efficiency |
| TRL status | Screening: 9 BFB gasifier: 8 Syngas engine: 8 | Water washing: 7, less with energy crops Pelleting: 9 BFB gasifier: 8 Syngas engine: 8 |
| Warning flags raised | Ash, Cl, K | None |
| Technical issues | Ash still high, can be wet/low LHV Expensive trucking | Chain less direct (extra transport step) Waste water disposal Fire risk from bulk wet chip storage Pelleting energy use |
| Technical benefits | Correct size, chain is direct | Very uniform, dry/high LHV Low ash, halides, sulphur & alkali metals (so less PM, CO, other emissions) Cheaper trucking |
| UK actors | Screening: Saxlund, Vecoplan, Komptech BFB gasifier: imported Outotec projects Syngas engine: Clark Energy reseller, CEG, SynTech Bioenergy/ETI demo | Water wash: (mostly arable focused), Blue Group, Forest Fuels/ETI demo, Uni of Leeds Pelleting: offices for Andritz, CPM, Bühler BFB gasifier: as for Chain 3 Syngas engine: as for Chain 3 |
| Barriers and risks | “Chicken and egg” for planting Storage area on-farm, long log storage Limited developers in UK, high risk investment/EPC | “Chicken and egg” for planting Storage area on-farm, long log storage Limited developers in UK, high risk investment/EPC, complex chain GHG threshold tight post-2025 |
| UK deployment opportunities | UK experience relatively limited Projects focusing on wastes, steam cycle ETI gasifier demo first opportunity Share screening kit | UK experience limited, esp. water wash Projects focusing on wastes, steam cycle ETI washing demo unlikely to be tested with ETI gasifier demo, so first opportunities will be in subsequent plants/activities Existing UK pellet mills could deploy water washing onsite |

Chain 3 & 4 costs are extremely high (well above likely feasible market + policy support rates), and are dominated by factors unrelated to technical improvement or biomass chemical properties. There are few individual opportunities that enable Chain 4 cross-overs, with the value of water washing and pelleting highest when using very wet feedstocks or screening costs are too high. However, these cost benefits are primarily due to the pellet densification, not due to water washing.

Importantly, water washing is able to clean up the TEABPP feedstocks to comply with BFB gasifier specifications, and avoid any warning flags being raised¹⁰¹, and could also reduce PM, halide and other plant emissions. So although Chain 4 is very unlikely to achieve a cross-over, the extra costs of Chain 4 might have to be paid if the TEABPP feedstocks are to be used in a BFB gasifier – i.e. water washing might be essential due to biomass specification requirements. Water washing is therefore worth exploring for combustion and gasification applications (and for dirtier feedstocks like waste wood), but further work is needed to optimise the process conditions for long rotation forestry and the TEABPP feedstocks (short rotation forestry, perennial energy crops).

Implementation of this complex Chain 4 is risky, as there is limited experience, and several different actors involved. Although the Forest Fuel/ETI washing demo¹⁰² will soon be operational, the scope of the remaining ETI programme is only to conduct combustion testing with the washed fuels, and not gasification. Similarly, the ETI/SynTech Bioenergy BFB gasifier + syngas engine demo is not planning to use washed biomass.

Therefore, if both demos are successful, separate follow-on activities (outside of the ETI's programmes) by the partners involved, or establishment of new water washing and new BFB gasifier plants will be the first opportunity for gasification of washed biomass to occur at scale in the UK. **The recommendation for ETI, Supergen Bioenergy and industry is to await the successful conclusion of both these demonstration plants' planned ETI activities, and then either encourage trials of unwashed and washed energy crops/SRF within the gasifier demo plant, or within other similar gasifiers.** Both steps will take time to commercialise (10+ years), provided there is market demand and risk appetite, before full Chain 4 integration is possible.

8.1.3 Chain 7 & Chain 6 vs. Chain 5

As a reminder from Figure 4.9, Figure 4.11 and Figure 4.13, Chains 5, 6 and 7 each comprise feedstock harvesting and collection, natural drying during on-farm shed storage/tarp storage in-forest, followed by:

- Chain 5: small truck transport to a screening plant (includes an initial chipping step), storage of chips in a warehouse, then large truck transport to a large-scale CFB combustion plant (generating power).
- Chain 6: small truck transport to a **pelleting plant** (which includes initial chipping and screening steps), pellet storage in a silo, then large truck transport to a large-scale CFB combustion plant (generating power).
- Chain 7: small truck transport to a **chemical washing plant** (which includes initial chipping and screening steps), natural drying of chips in a warehouse, then pelleting and pellet silo storage, before large truck transport to a large-scale CFB combustion plant (generating power).

¹⁰¹ Across all the chains, note that additional costs are already incurred within the model as biomass contaminants increase, based on the relationships set out in the D3 report. However, these additional costs (slopes and/or steps) do not necessarily kick in at each of the warning flag limits, and some biomass contaminants are assumed to not have an impact on costs due to a lack of data, even though they have a warning flag limit (for example, Aluminium). The warning flag limits are therefore useful to highlight where typical biomass specifications for the conversion technology might be exceeded, and potentially cause issues (e.g. with permitted emissions, equipment warranties, expected lifetime), but these are not directly linked to the additional cost formulae, which were derived separately.

¹⁰² The Forest Fuel/ETI washing demo will also provide useful information to validate the data in this project, and vice versa, ETI might be able to use the TEABPP modelling to assess any wider supply chain benefits from the water washing technology that is developed.

Table 8.3: Chains 7 & 6 vs. 5 quantitative and qualitative summary

| Criteria | Chain 5 | Chain 6 | Chain 7 |
|------------------------------------|---|---|--|
| Base Case LCOE | £123/MWh _e | £144/MWh _e | £164/MWh _e |
| Most sensitive parameters | Miscanthus bales distance Screened chip distance CFB combustion CAPEX Woody logs distance | Miscanthus bales distance CFB combustion CAPEX Silo storage time Woody logs distance | Miscanthus bales distance CFB combustion CAPEX Chemical washing capacity |
| Cross-overs | NA | Lots of options. Clear cross-over with distance, possible with warehouse storage or very small screening. Miscanthus better | No single options. May need unique combination of Miscanthus, long distances, tiny screening. |
| Optimum Case LCOE | £81/MWh _e | £98/MWh _e | £104/MWh _e |
| Key innovations | CFB combustion CAPEX CFB combustion efficiency CFB combustion lifetime | CFB combustion CAPEX CFB combustion efficiency CFB combustion lifetime Pellet electricity use Pellet binder use | CFB combustion CAPEX CFB combustion efficiency Chemical wash N content Chemical wash alkali use |
| TRL status | Screening: 9 CFB combustion: 9 | Pelleting: 9 CFB combustion: 9 | Chemical washing: 4 Pelleting: 9 CFB combustion: 9 |
| Warning flags raised | Ash, Cl, Br, K | Ash, Cl, K | None |
| Technical issues | Ash still high, can be wet/low LHV Expensive trucking | Ash still high Pelleting energy use | Increased N content (NO_x) Waste water disposal Fire risk from bulk wet chip storage Pelleting energy use |
| Technical benefits | Correct size | Very uniform, dry/high LHV Cheaper trucking | Very uniform, dry/high LHV Zero ash, halides & alkali metals (so less PM, CO, S, Cl emissions, CAPEX savings) Cheaper trucking |
| UK actors | Screening: Saxlund, Vecoplan, Komptech CFB combust: AFW sold up, and offices for Doosan, Metso, B&W Volund, Andritz, Valmet | Pelleting: offices for Andritz, CPM, Bühler CFB combust: as for Chain 5 | Chemical washing: Uni of Leeds Pelleting: as for Chain 6 CFB combust: as for Chain 5 |
| Barriers and risks | “Chicken and egg” for planting, many suppliers Storage area on-farm, long log storage Low technical risk, but large investment and lack of policy support | “Chicken and egg” for planting, many suppliers Storage area on-farm, long log storage Low technical risk, but large investment and lack of policy support | “Chicken and egg” for planting, many suppliers Storage area on-farm, long log storage Chemical wash R&D, >10yrs before ready Complex chain, large investment and lack of policy support GHG threshold fail in 2025 |
| UK deployment opportunities | Only 1-2 CFB plants in UK. Pipeline very limited as no policy, and EU rules favouring smaller CHP | As for Chain 5 + Existing UK pellet mills could use energy crops/SRF | As for Chain 6 + Longer-term, chemical washing could be installed at UK pellet mills |

Chain 5 & 6 power generation costs are more reasonable, but Chain 7 costs are high (above likely feasible market + policy support rates). The costs of these chains are determined by a few technical factors, such as CFB combustion plant CAPEX and silo storage time, but still no factors related to biomass chemical properties or pre-processing. There are several cross-over opportunities for Chain 6, with pelleting benefits highest for Miscanthus, long distances or long chip storage times. There are no individual opportunities that enable Chain 7 cross-overs, despite some benefits to the CFB combustion plants.

Importantly, chemical washing can clean up the TEABPP feedstocks to comply with CFB combustion specifications, and avoid warning flags being raised, and could also reduce PM, halide and other plant emissions (but may raise NO_x). Innovations should focus on reducing output nitrogen content and lowering chemical use and GHG emissions, plus safely dealing with waste water disposal. **ETI, Supergen Bioenergy or the Research councils could have a role in supporting this R&D in the mid-term**, but scaling up from the currently low TRL will take considerable time and effort, and commercialisation is only likely to happen in 10-20 years provided further costs reductions are found, water washing proves attractive, and chemical washing testing is also successful.

Pelleting cannot clean the biomass, but offers some limited innovation improvements in GHG emissions via lower use of binder and electricity, which will be easy to implement by actors already in the market. Although few UK actors would be involved, implementation of Chain 6 is straight forward for existing CFB plants and will happen immediately if required, **and does not require specific intervention by the ETI or others**. However, the future UK pipeline is very narrow, due to lack of policy support for large-scale biomass power plants.

8.1.4 Chain 10 & Chain 9 vs. Chain 8

As a reminder from Figure 4.15, Figure 4.17 and Figure 4.19, Chains 8, 9 and 10 each comprise feedstock harvesting and collection, natural drying during on-farm shed storage/tarp storage in-forest, followed by:

- Chain 8: small truck transport to a pelleting plant (which includes initial chipping and screening steps), pellet storage in a silo, then large truck transport to a very large-scale EF gasifier + syngas CCGT (generating power).
- Chain 9: small truck transport to a **torrefaction + pelleting plant** (which includes initial chipping and screening steps), torrefied pellet storage in a silo, then large truck transport to a very large-scale EF gasifier + syngas CCGT (generating power).
- Chain 10: small truck transport to a **pyrolysis plant** (which includes an initial grinding step), pyrolysis oil storage in a tank, then large tanker transport to a very large-scale EF gasifier + syngas CCGT (generating power).

Table 8.4: Chains 10 & 9 vs. 8 quantitative and qualitative summary

| Criteria | Chain 8 | Chain 9 | Chain 10 |
|----------------|-----------------------|-----------------------|-----------------------|
| Base Case LCOE | £124/MWh _e | £132/MWh _e | £182/MWh _e |

| Criteria | Chain 8 | Chain 9 | Chain 10 |
|------------------------------------|--|--|--|
| Most sensitive parameters | Miscanthus bales distance EF gasifier + CCGT capacity Silo storage time Woody logs distance | Miscanthus bales distance EF gasifier + CCGT capacity Silo storage time | Miscanthus bales distance Miscanthus inherent ash |
| Cross-overs | NA | Some options, but only if high LHV for torrefied pellets, long silo storage or extremely long distances | No single options. May need unique combination of very low ash SRF, very efficient and low CAPEX pyrolysis, and v small pelleting. |
| Optimum Case LCOE | £71/MWh _e | £70/MWh _e | £74/MWh _e |
| Key innovations | CCGT efficiency EF gasifier efficiency EF gasifier CAPEX | CCGT efficiency EF gasifier efficiency Torrefied pellet LHV Torrefied pellet electricity use | Pyrolysis efficiency CCGT efficiency EF gasifier efficiency Pyrolysis electricity export |
| TRL status | Pelleting: 9 EF gasifier: 6 Syngas CCGT: 8 | Torrefaction + pelleting: 8, but ~6 for energy crops EF gasifier: 6 Syngas CCGT: 8 | Pyrolysis: 8, but ~6 for energy crops EF gasifier: 6 Syngas CCGT: 8 |
| Warning flags raised | Cl | Cl, Br | None |
| Technical issues | Ash still high Pelleting energy use EF gasifier grinding power | Torrefaction losses Slightly increases ash, metals, S, N | Pyrolysis low efficiency Bio-oil unstable, corrosive Moisture means transport costs slightly higher |
| Technical benefits | Very uniform, dry/high LHV | Very uniform, very high LHV Easy EF gasifier grinding Cheaper trucking | No EF gasifier grinding or handling Low ash, halides, N, S, alkali metals (less PM, CO, S, NO _x emissions) Low chain GHG emissions |
| UK actors | Pelleting: offices for Andritz, CPM, Bühler EF gasifier: none Syngas CCGT: past failures, Air Products & Rolls sold up | Torrefaction: Torftech, Supergen, CEG Pelleting: as for Chain 8 EF gasifier: none Syngas CCGT: as for Chain 8 | Pyrolysis: 2G BioPOWER, Anergy, CARE, EPI, Next BTL, Torftech EF gasifier: none Syngas CCGT: as for Chain 8 |
| Barriers and risks | “Chicken and egg” for planting, many suppliers, time to establish buffers Storage area on-farm, long log storage High technical risk, complex EPC, no UK experience (past failures), large investment and lack of policy support | As for Chain 8 + Added torrefaction risks with energy crops, and lack of standardisation | As for Chain 8 + Added pyrolysis risks with energy crops + Distributed plants have too high CAPEX + Lack of bio-oil treatment, standardisation and optimisation to EF gasifiers |
| UK deployment opportunities | No plants or projects in UK, and no policy support. May change in 20+ yrs with H ₂ , biofuel or BECCS drivers UK pellet mills could then use energy crops/SRF | As for Chain 8 + Existing UK pellet mills could retrofit torrefaction | As for Chain 8 UK pyrolysis heating oil market is limited. Chain 10 is only likely in very long-term |

Chain 8 & 9 power generation costs are reasonable, but Chain 10 costs are very high (well above likely feasible market + policy support rates). The costs of these chains are mostly determined by non-technical factors (other than silo storage time), but Chain 10 is strongly influenced by the biomass ash content. There are some cross-over opportunities for Chain 9, with torrefaction+pelleting benefits highest for long distances and storage times, and if high LHV torrefied pellets can be achieved. There are no individual opportunities that enable Chain 10 cross-overs.

Importantly, pyrolysis should be able to clean up the TEABPP feedstocks to comply with EF gasifier specifications, and avoid warning flags being raised, and could also reduce PM, NO_x, halide and other plant emissions. Innovations should focus on improving pyrolysis bio-oil yields for higher-ash energy crop/SRF feedstocks, and overall plant thermal integration (as exported power GHG benefits will shrink). Even then, further cost reductions may be required to justify this pre-processing step, due to a lack of any cross-overs. **ETI, Supergen Bioenergy or the Research councils could have a role in supporting this R&D in the mid-term.** Given the lack of EF gasifier and syngas CCGT experience or pipeline in the UK, high risks and lack of policy support, these pyrolysis activities (with some UK actors able to benefit) will likely have to happen independently to EF gasifier + CCGT plant development. As CCGTs do not lend themselves to small pilots, it will likely only be in the long-term (20+ years) before future full Chain 10 integration and optimisation opportunities present themselves.

Torrefaction cannot clean the biomass (likely concentrates contaminants), so does not remove warning flags or benefit conversion plant emissions. Innovation should focus on increasing the LHV of torrefied pellets, optimisation with energy crop/SRF feedstocks, and reducing electricity use. **Given the potential benefits over pelleting even at modest transport distances, ETI, Supergen Bioenergy or the Research councils should have a role in investigating torrefaction further in the near-term.** As above, torrefaction improvements will likely have to happen independently from any EF gasifier + syngas CCGT developments. Although this was not modelled in TEABPP, torrefaction developers should potentially focus on use of their pellets in existing combustion plants first, and examine the costs of retrofitting existing pellet mills. Full Chain 9 integration and optimisation is only likely in the long-term (20+ years).

8.2 Prioritised recommendations

The TEABPP feedstocks in scope (Miscanthus, SRC willow, SRF) are generally dirtier than debarked LRF (e.g. imported pellets), but considerably cleaner than waste wood and other contaminated feedstocks, and hence the benefits of pre-processing have been found to be relatively limited during the TEABPP project. This is also due to the relatively low sensitivity of the conversion technologies to the biomass parameters (i.e. availability, efficiency and opex are not too severely impacted by higher contaminant levels, even when these levels exceed the warning flag limits), based on the best available information to hand and as approved by ETI and its experts.

The results of the study could have been different if dirtier feedstocks were included in scope from the outset, or operational data were collected from specific plants (but experience with different feedstocks is usually highly confidential), or if a chemical engineering analysis was conducted of the potential (combined) impacts of various contaminants on boiler and gasifier surfaces and hence plant operational strategies. Any of these approaches would likely have taken considerably more

time and effort, and the latter two approaches would have made the TEABPP results much more specific to the design of the individual systems chosen, and hence less generally applicable.

Therefore, in conclusion, within the scope of the feedstocks and chains selected, the following recommendations can be made from the TEABPP project:

- **Conversion technology** innovation improvements, especially CAPEX and efficiencies, result in dramatic chain improvements, and are worth exploring further as these will be required to increase the competitiveness of all of the TEABPP chains. Improvements in underfeed boilers and CFB combustion technologies can be achieved by existing actors in the near term, but developments in fluidised gasifiers and syngas engines for the near to mid-term, and EF gasifiers and syngas CCGT for the long-term will need more support given high risks and few developers. However, these conversion improvements do not fundamentally change the regions in which pre-processing pays off, and are not the primary focus of the TEABPP project. Some pre-processing improvements can further reduce conversion costs (e.g. avoiding SNCR kit); whereas others will reduce the scope or need for conversion technology improvements (e.g. plants are already operating more efficiently by using cleaner, drier feedstocks). **High priority.**
- **Torrefaction+pelleting** plants should focus on increasing product LHV, optimising with energy crop/SRF feedstocks, and reducing electricity use. Given the potential (but slim and uncertain) cost and GHG emission benefits over pelletizing if improvements are made, ETI, Supergen Bioenergy or the Research councils should investigate torrefaction developments and look to reduce uncertainties in the near-term. **Medium-High priority.**
- **Chemical washing** plants, if developed, should focus on reducing output nitrogen content and lowering chemical use and GHG emissions, plus safely dealing with waste water disposal. ETI, Supergen Bioenergy or the Research councils could have a role in supporting this R&D in the mid-term, but scaling up will take time, and is dependent on further costs reductions and water washing success. **Medium priority.**
- **Water washing** plants should focus on optimisation with forestry then perennial energy crop feedstocks, and compliance with combustion and gasification plant feedstock limits and non-GHG emissions limits. Recommendation for ETI, Supergen Bioenergy or industry to carry out washed biomass testing in gasification plants in the near to mid-term. **Medium priority.**
- **Pyrolysis** plants should focus on significantly improving bio-oil yields when using higher-ash energy crop/SRF feedstocks, and overall plant thermal integration. ETI, Supergen Bioenergy or the Research councils could have a role in supporting this R&D in the mid-term, and reducing technology uncertainties, but power generation via pyrolysis is still likely to remain expensive and only as a long term potential option. **Medium priority.**
- **Field washing** plants should focus on ash and halide removal, and optimisation with biomass. However, the technology does not appear to offer significant enough benefits to warrant further work, and given its simplicity, could be delivered by the market in the near to mid-term if required. **Low priority.**
- **Pelletizing** plants should focus on reductions in power consumption and binder use, potentially replacing starch with cheaper waste materials, to drive down GHG emissions.

These changes will likely be driven by existing markets and actors in the near term if required, and do not need intervention. Pelleting was responsible for the only clear cross-over in TEABPP, based on >800km distances. **Low priority.**

More specific innovation targets for each technology are discussed in Section 6.5.